

**ARCHAEOLOGICAL ASSESSMENT  
AT  
TILES 2 AND 3,  
CAPPAGH, DUBLIN 22,  
(CLONBURRIS SDZ)**

**LICENCE NOS. 22E0719/ 22R0359**

**ON BEHALF OF: CAIRN HOMES PROPERTIES**

**T2 ITM 705988 ,732563 / T3 ITM 705696,732594**

**PLANNING REFERENCE: SDZ22A/0017**

**LICENCEE: FERGAL MURTAGH**

**REPORT STATUS: FINAL**

**MARCH 2023**

**IAC PROJECT REF.: J3803**

**DOCUMENT CONTROL SHEET**

DATE	DOCUMENT TITLE	REV.	PREPARED BY	REVIEWED BY	APPROVED BY
27.03.2023	Archaeological Assessment at Tiles 2 and 3, Cappagh, Dublin 22, Clonburris SDZ	0	F. Murtagh	S. Delaney	F. Bailey

## ABSTRACT

IAC Archaeology has prepared this report on behalf of Cairn Homes Properties, to study the impact, if any, on the archaeological and historical resource of a proposed development, within two parcels of land known as Tile 2 and Tile 3, located at Cappagh townland, Dublin 22 within the Clonburris SDZ (ITM 705838,732570). The assessment was carried out by Fergal Murtagh under excavation licence 22E0719 and metal detection licence 22R0359 during November 2022 and March 2023. It follows a previous geophysical survey report carried out in June 2022 (Dowling 2022).

A total of 10 trenches were excavated across Tiles 2 and 3, including six trenches excavated in Tile 2 and six trenches excavated in Tile 3. Trenches were placed to target geophysical anomalies and green space where geophysical survey was unable to reach. One trench (T9) was spilt to avoid an upstanding metal cap for a bore hole. Two text trenches in Tile 2 (originally Tile 3) were hand excavated in order to assess potential remains associated with recorded enclosure DU017-036.

In March 2023, following the issuing of an RFI, two additional hand dug trenches were excavated across the projected extent of the possible enclosure DU017-036, partially located within Tile 3.

### Tile 2

Ground disturbances associated with the proposed development may have an adverse impact on the potential archaeological remains identified in Archaeological Area 1, which may relate to c. 80% of the recorded enclosure site DU017-036.

It is acknowledged that the preservation in-situ of archaeological remains is the best form of long-term conservation; however, due to the layout and density requirements of the approved SDZ, it is not possible to facilitate the preservation of AA1. Although the site is a recorded monument, no significant or diagnostic remains have been identified during testing. It is recommended that an area measuring c. 50m x 55m be opened around the possible enclosure DU017-0036 identified in Trenches 7, 8 and 13 (within the full extent of Tile 2) in order to facilitate its preservation by record of AA1. This should be carried out by an archaeologist under licence from the National Monuments Service of the DoHLGH.

Ground disturbances may have an adverse impact on previously unrecorded small or isolated archaeological features or deposits that have the potential to survive beneath the current ground level and outside the footprint of the excavated test trenches.

It is recommended that all topsoil stripping in Tile 2 (with the exception of the disturbed eastern extent) be monitored by a suitably qualified archaeologist. If any features of archaeological potential are discovered during the course of the works further archaeological mitigation may be required, such as preservation *in situ* or by record. Any further mitigation will require approval from the National Monuments Service of the DoHLGH.

### **Tile 3**

Ground disturbances associated with the proposed development may have an adverse impact on the potential archaeological remains identified in Archaeological Area 1, which may relate to c. 20% of the recorded enclosure site DU017-036.

It is recommended that the small section of AA1 within Tile 3 be preserved by record as part of the Tile 2 works (as per the above mitigation measures). This will enable the whole of the site to be preserved by record in one phase of works.

Ground disturbances associated with the proposed development will have an adverse impact on the archaeological remains identified in Archaeological Area 2.

It is recommended that an area measuring c. 10m x 10m be opened around the metallised surface found in Trench 1 in order to facilitate its preservation by record (Archaeological Area 2) with further monitoring to establish the total length. All works should be carried out by an archaeologist under licence to the National Monuments Service of the DoHLGH.

Ground disturbances may have an adverse impact on previously unrecorded small or isolated archaeological features or deposits that have the potential to survive beneath the current ground level and outside the footprint of the excavated test trenches.

It is recommended that all topsoil stripping in Tile 3 be monitored by a suitably qualified archaeologist. If any features of archaeological potential are discovered during the course of the works further archaeological mitigation may be required, such as preservation *in situ* or by record. Any further mitigation will require approval from the National Monuments Service of the DoHLGH.

## CONTENTS

ABSTRACT.....	I
CONTENTS.....	III
List of Figures.....	iv
List of Plates .....	iv
<b>1 INTRODUCTION.....</b>	<b>1</b>
1.1 General .....	1
1.2 The Development .....	1
<b>2 ARCHAEOLOGICAL AND HISTORICAL BACKGROUND .....</b>	<b>4</b>
2.1 Summary of Desktop Assessment .....	4
2.2 Summary of Previous Archaeological Fieldwork.....	6
2.3 Cartographic Analysis .....	8
2.4 Summary of Geophysical Results.....	9
2.5 Aerial Photographic Analysis .....	9
2.6 Topographical Files.....	9
<b>3 ARCHAEOLOGICAL TESTING .....</b>	<b>11</b>
3.1 General .....	11
3.2 Metal Detection Results (22R0359).....	11
3.3 Testing Results Tile 2 .....	11
3.4 Testing Results Tile 3 .....	12
3.5 Conclusions.....	13
<b>4 IMPACT ASSESSMENT AND MITIGATION STRATEGY.....</b>	<b>14</b>
4.1 Impact Assessment.....	14
4.2 Mitigation .....	14
<b>5 REFERENCES .....</b>	<b>16</b>
<b>APPENDICES .....</b>	<b>I</b>
Appendix 1 Trench Results.....	i
Appendix 2 Contexts .....	iii
Appendix 3 Finds list .....	iii
Appendix 4 RMP Sites within the Surrounding Area .....	iv
Appendix 5 Legislation Protecting the archaeological Resource .....	v
Appendix 6 Impact Assessment & the Cultural Heritage Resource .....	viii
Appendix 7 Mitigation Measures & the Cultural Heritage Resource .....	x

### FIGURES

### PLATES

### **LIST OF FIGURES**

- Figure 1 Locations of Tile 2 and Tile 3 with nearby archaeology
- Figure 2a Plan of proposed development in Tile 2
- Figure 2b Plan of proposed development in Tile 3
- Figure 3 Extract from historic OS maps (1843 and 1937) showing Tile 2 and Tile 3
- Figure 4 Test trench results
- Figure 5 Detail view of Archaeological Areas

### **LIST OF PLATES**

- Plate 1 Trench 7, hand excavation, facing northeast
- Plate 2 Trench 8, mid-excavation with metal detection ongoing facing west
- Plate 3 Trench 13, metal detection of topsoil, facing west
- Plate 4 Metal object recovered through metal detection (22R0359)
- Plate 5 Topsoil finds recovered from Trench 7
- Plate 6 Topsoil finds recovered from Trench 8
- Plate 7 Possible Dublin ware recovered from Trench 8 topsoil
- Plate 8 Mid-excavation of linear feature C7.1, facing east
- Plate 9 Mid-excavation view of linear feature C8.1, facing northeast
- Plate 10 Mid-excavation view of linear feature C13.1, facing southwest
- Plate 11 Trench 13, post-excavation facing west
- Plate 12 Trench 14, post-excavation, facing east
- Plate 13 Modern field drain within Trench 12, facing southeast
- Plate 14 Metalled surface C1.2 below spread C1.1, facing east
- Plate 15 Trench 1, post-excavation facing west
- Plate 16 Trench 4, post-excavation facing south
- Plate 17 Trench 5, post-excavation facing southwest
- Plate 18 Trench 9, post-excavation facing west
- Plate 19 Trench 11, post-excavation, facing south
- Plate 20 Trench 12, post-excavation, facing north

# 1 INTRODUCTION

## 1.1 GENERAL

The following report details the results of a programme of archaeological testing undertaken at two parcels of land (Tile 2 and Tile 3), which is located at Cappagh townland in the Clonburris SDZ (ITM 705838,732570) (Figure 1), prior to proposed development. This assessment has been carried out to ascertain the potential impact of the proposed development on the archaeological resource that may exist within the proposed development area. The assessment was undertaken by Fergal Murtagh of IAC Archaeology (IAC), on behalf of Cairn Homes Properties and under licence 22E0719, as issued by the National Monuments Service of the Department of Housing, Local Government and Heritage (DoHLGH).

Initial test trenching commenced at the site on the 2nd of November and continued for three days. This was carried out using hand tools and a 13 tonne 360 degree tracked excavator, with a flat, toothless bucket, under strict archaeological supervision. A total of 10 trenches were mechanically investigated across the test area and two were excavated by hand. This included six trenches within Tile 2 and six trenches in Tile 3. Testing followed on from a geophysical survey carried out by Ger Dowling in the June 2022.

Following a change in the redline development boundaries of both Tiles 2 and 3 (post-November testing assessment), a Request for Further Information (RFI) was issued by South Dublin County Council (Planning Ref.: SDZ22A/0017). This included a request to carry out additional test trenching within Tile 3. Two additional hand dug trenches were excavated within Tile 3, during March 2023.

Interpretation of the geophysical survey results revealed a number of features of potential archaeological significance, including a semi-circular, positive anomaly, measuring some 36m in diameter (north—south). This feature, may correspond to a cropmark enclosure DU017-036, which appears to be bisected, east to west, by a possible ditch and is conceivably associated with several possible pits/spreads (Dowling 2022).

There was extensive evidence for previous agricultural activity across the area including a series of linear anomalies that appear to represent a relict field system/s delimited by ditches. Two of these are potentially associated with former cultivation (Ibid.).

## 1.2 THE DEVELOPMENT

### **Tile 2 (Figure 2a)**

Construction of a mixed-use development comprising 594 apartments, office floorspace, 4 retail units, a creche and urban square in the Clonburris Development Areas CUCS3 & CSWS3 of the Clonburris SDZ Planning Scheme 2019 as follows, 594

apartments (255 one bedroom apartments, 307 two bedroom apartments and 32 three bedroom apartments as follows;

Block A (4 and 6 storeys with undercroft) comprises 96 apartments consisting of 36 one bedroom apartments, 48 two bedroom apartments and 12 three bedroom apartments (with creche c. 609sq. m at ground and first floor as well as play area;

Block B (6 storeys with undercroft) comprises 77 apartments consisting of 44 one bedroom apartments, 28 two room apartments and 5 three bedroom apartments;

Block D (5 and 7 storeys with undercroft) comprises 71 apartments consisting of 39 one bedroom apartments and 32 two bedroom apartments;

Block E (6 storeys with undercroft) comprises 100 apartments consisting of 47 one bedroom apartments, 48 two bedroom apartments and 5 three bedroom apartments;

Block F (5 and 7 storeys with undercroft) comprises 124 apartments consisting of 57 one bedroom apartments, 61 two bedroom apartments and 6 three bedroom apartments;

Block G (1, 2 and 4 storeys with undercroft) comprises 65 apartments consisting of 16 one bedroom apartments, 45 two bedroom apartments and 4 three bedroom apartments;

Block H (4 storeys with undercroft) comprises 61 apartments consisting of 16 one bedroom apartments and 45 two bedroom apartments.

Mixed use development comprising, commercial office development in Block C of 6 storeys with parapet above to 7 storey equivalent on elevations, as well as a creche (c. 609sq. m) at ground floor and first floor of Block A.

Vehicular access will be from the permitted Clonburris Southern Link Street (SDZ20A/0021) and R 113 to the east; Public Open Space/landscaping of c. 0.52 hectares (urban square) and linear open space (0.72 hectares) as well as a series of communal open spaces to serve apartments over undercroft level (and internal communal open space c. 685 sq.m).

The development will also provide for all associated works and infrastructure to facilitate the development to include all ancillary site development works including footpaths, landscaping boundary treatments, public, private open space areas, car parking (396 no. spaces in a mixture of undercroft spaces Block A, Block B&D and Block E&F) and bicycle parking (1,232 spaces at undercroft and surface levels), single storey ESB substations/bike/bin stores, green roofs, solar panels at roof level of apartments, plant areas within blocks and all ancillary site development/construction works; Permission is also sought for connection to water supply, and provision of foul drainage infrastructure.



### **Title 3 (Figure 2b)**

The construction of 157 no. dwellings on a site of c. 3.45 hectares in the Clonburris South-West Development Area of the Clonburris Strategic Development Zone (SDZ) Planning Scheme 2019 as follows:

- i. 81 no. houses comprising 4 no. 2-bedroom houses, 65 no. 3-bedroom houses and 12 no. 4-bedroom houses (all 2-no. storey with associated private open space and car parking);
- ii. 76 no. apartment units consisting of 26 no. 1-bedroom and 50 no. 2-bedroom units within Block 1 (4 no. storeys);
- iii. Vehicular access will be provided from the permitted street under SDZ21A/0022 and the permitted Clonburris Southern Link Street (SDZ20A/0021) and R113 (Fonthill Road) to the east;
- iv. All ancillary site development works including footpaths, landscaping boundary treatments, public and private open space areas, car parking (170 no. spaces) and bicycle parking (170 no. spaces), single-storey ESB sub-stations, bin and bicycle stores and all ancillary site development/construction works.

## 2 ARCHAEOLOGICAL AND HISTORICAL BACKGROUND

### 2.1 SUMMARY OF DESKTOP ASSESSMENT

#### **Prehistoric Period**

##### *Mesolithic Period (c. 7000–4000 BC)*

Although recent discoveries may provide evidence of a human presence in the southern half of Ireland from the Upper Palaeolithic (Dowd and Carden 2016), the Mesolithic period is the first time for which there is widespread evidence of human occupation across the island of Ireland. During the Mesolithic, small communities hunted, fished and foraged. Coastal and riverine resources were of particular importance, with groups migrating to exploit seasonal resources. As a result of settlement evidence dating to the Mesolithic period is rare. Often the only trace of these communities are scatters of flint artefacts or the by-products of their manufacture. Occasionally, shell middens are also uncovered dating to this period; however, there are no sites dated to the Mesolithic in the vicinity of the proposed development site.

##### *Neolithic Period (c. 4000–2500 BC)*

During the Neolithic period communities became less mobile and their economy became based on the rearing of stock and cereal cultivation. This transition was accompanied by major social change. Agriculture demanded an altering of the physical landscape. Forests were cleared and field boundaries constructed. There was a greater concern for territory, which saw the construction of large communal ritual monuments called megalithic tombs, which are characteristic of the period. There are no recorded sites of Neolithic date within the immediate vicinity of the proposed development site.

##### *Bronze Age Period (c. 2500–800 BC)*

The Bronze Age in Ireland was marked by the use of metal for the first time. As with the transition from Mesolithic to Neolithic, the transition into the early Bronze Age was accompanied by changes in society. The tradition of megalithic tombs ended in the early Bronze Age in favour of individual, subterranean cist or pit burials that were either in isolation or in small cemeteries. These burials contained inhumed or cremated remains and were often, but not always, accompanied by a pottery vessel. Different forms of burial barrows were also being constructed during this period, as well as ceremonial monuments such as henges. Unenclosed cemeteries are also known from this period and are termed flat cemeteries.

In general, ring-ditches date to the Bronze Age, with the earlier examples being simpler in form and later examples incorporating entrances and a wider range of burial practices. Ring-ditches appear to have continued to be built and earlier monuments re-used, during the Iron Age and early medieval period.

Bronze Age activity is often clearly identifiable in the landscape by the presence of *fulachtaí fia* or burnt mounds. Thousands of *fulachtaí fia* have been recorded in

Ireland making them the most commonly excavated prehistoric monument in the country. These sites were used to heat water using hot stones. They have been interpreted as places where cooking, dyeing, brewing, or bathing took place (O' Kelly 1954, Quinn and Moore 2009). There are no identified examples in the immediate area of the proposed development.

#### ***Iron Age Period (c. 800 BC – AD 400)***

Compared to the rest of Irish prehistory, there is little evidence in Ireland, as a whole, representing the Iron Age. There was significant continuity from the Bronze Age into the Iron Age. There are no recorded sites of Iron Age date within the immediate vicinity of the proposed development site.

#### **Early Medieval Period (AD 400–1100)**

Ireland, as depicted in the surviving sources, was entirely rural in the early medieval period. At this time, the island was a patchwork of larger and smaller kingdoms known as *túath* and *trícha cét* respectively. Byrne (1973) estimates that there were as many as 150 kings in Ireland at any time, each ruling over a basic territorial unit known as the *túath*. If estimates placing the population of Ireland in the early medieval period at quarter to half a million people are accurate, then each king would have ruled over between 1,700 and 3,300 subjects within his *túath* (Stout 2017). From the 6th century, many of these subjects would have lived in enclosed settlements such as ringforts.

Secular habitation sites in the early medieval period include crannógs, cashels and ringforts, which are largely defined as circular enclosures surrounded by banks and ditches. In addition to these, there is some evidence for unenclosed settlements which are more difficult to identify in the archaeological record. The ringfort or *ráth* is considered to be the most common indicator of settlement during the early medieval period. Ringforts are strongly associated with agricultural land and, as such, are rarely situated at higher altitudes. Ringforts and potential ringforts are the most common archaeological sites recorded across the Irish landscape. Sites recorded as enclosures, in many cases, represent damaged or denuded ringforts or similar early medieval sites though some do date to prehistoric times. An enclosure (DU017-036) is located within the proposed development area.

#### **Medieval Period (AD 1100–1600)**

The medieval period began with the arrival of the Anglo-Normans in Ireland in support of the deposed King of Leinster, Diarmait MacMurchadha. By the end of the 12th century the Normans had succeeded in conquering much of the country (Stout and Stout 1997). Leinster, including Dublin and Meath, was 'sub-infeudated', meaning that great swathes of land were parcelled out among the Anglo-Norman elites. The Anglo-Norman tenurial system more or less appropriated the older established land units known as *túaths* in the early medieval period but described the territories as manors (MacCotter 2008).

### **Post-medieval Period (AD 1600-1900)**

The 17th century witnessed the systematic reduction of all of Ireland to English authority, largely through conflicts and the forced settlements, known as 'The Plantations'. As part of the process of achieving colonial dominion a number of surveys and mapping programmes were completed throughout the post-medieval period. Simington's Civil Survey of 1654–56, was an inquisition that visited each barony (land division) and took depositions from landholders based on parish and townland, with written descriptions of their boundaries to facilitate the transfer of lands. Subsequent to the Civil Survey, a project known as the Down Survey 1656–58, used the collected cadastral information to map all forfeited lands. This survey was overseen by the surgeon-general of the English army, William Petty, and a number of former soldiers. It was not just a project of mapping but of social engineering that was underpinned by a massive transfer in landownership from Irish Catholics to English Protestants. This survey is the first ever detailed land survey on a national scale anywhere in the world and gives great insight in Ireland at this time. The castle (DU017-032001) at Neilstown located c. 670m to the northeast of the proposed development is shown and labelled as 'old castle', suggesting that the castle was already of substantial age by the time of this map. It is shown in association with a second smaller structure which may represent the 16th/17th century house (DU017-032002).

The 17th century also saw a dramatic rise in the establishment of large residential houses around the country. The large country house was only a small part of the overall estate of a large landowner and provided a base to manage often large areas of land that could be located nationwide. Lands associated with the large houses were generally turned over to formal gardens, which were much the style of continental Europe. By the mid-18th century more natural parkland landscapes were in favour although the creation of these required considerable effort, including moving earth, removal of field boundaries, culverting streams to form lakes and quite often roads were completely diverted to avoid travelling anywhere near the main house or across the estate.

## **2.2 SUMMARY OF PREVIOUS ARCHAEOLOGICAL FIELDWORK**

Archaeological testing and metal detection has recently been carried out in advance of the infrastructure development within the Clonburris SDZ under licences 20E0390 and 20R0168 and a number of the test trenches were excavated within the boundary of the proposed development areas and immediately adjacent. A number of archaeological areas were identified within the wider tested area. Of particular significance to the current development area are AA1 and AA2, which were located to the south of Tile 2 and Tile 3 (O' Neill 2020). AA1 comprises three pits (C55.1, C55.2 and C55.3), with evidence for burning and charcoal, identified in Trench 55 in Cappagh to the east of the R113. No dating evidence was recovered from these pits during testing. AA2 comprises a single large pit (C57.1), capped in clay and containing charcoal. The pit was identified in Trench 57 in Cappagh to the east of the R113. This may be the site of a charcoal-production pit. No dating evidence was recovered during testing. AA2 lies across the existing field boundary to the east of AA1 in the field to the west. In addition, post-medieval features were identified within the area

of the haul route of the proposed development area. These features were recorded as 'Kiln Area 3'. Previously unrecorded post-medieval brick manufacture was evident in Trenches 27 and 28 in Kishoge, in the fields just to the east of the R136. An area of substantial brick debris and burning (C27.1/C28.1) was identified that is potentially derived from a post-medieval brick manufacturing kiln. The debris and burning extended over an area measuring 14m (east–west) by 30m (north–south). Two further brick kilns were identified during testing further to the west in the townland of Grange and AA3 was identified to the east in the townland of Cappagh and consisted of a possible charcoal-production pit.

Archaeological features identified as part of the infrastructure investigations were preserved by record as part of the infrastructure development in September 2022.

Archaeological testing was also carried out c. 100m east of the proposed development area under licence 21E0084. This phase of testing did not identify any additional features of archaeological potential, although a number of linear features, interpreted as modern drains and field boundaries, were noted (O' Neill et. al. 2021).

Test trenching was carried out c. 500m to the northeast of the proposed development area. Human remains were identified during the first phase of testing and subsequent excavation was carried out. It was noted that the human remains were in poor condition, the remains were believed to be of a female, 25–29 years at time of death, and 1.6m in height. No other features of finds were discovered during investigations (Nelis 2017:342, Licence ref.: 16E0409ext).

Archaeological testing has also been recently completed by the applicant within Tile 1 of the Clonburris SDZ, immediately to the south of Tile 2 and Tile 3 - (Murtagh 2022, Licence No. 22E0438). Testing revealed seven areas of archaeological significance, which have been designated as Archaeological Areas 1–7. These comprised;

- AA1: Charcoal spread and pit.
- AA2: Three pits containing heat-affected material.
- AA3: Three brick kilns or clamps.
- AA4: A charcoal-production pit.
- AA5: A charcoal-production pit.
- AA6: Concrete aligned with a structure depicted on the first edition OS map
- AA7: Possible paving on alignment of path/roadway depicted on first edition OS map

It is proposed to preserve these features by record, through archaeological excavation.

## 2.3 CARTOGRAPHIC ANALYSIS

### **Down Survey Maps of the Barony of Newcastle, c. 1655**

The Down Survey maps were created as a means to identify land ownership and while they are often scant in detail, major topographical features and occasional notable man-made landmarks are depicted. The castle (DU017-032001) at Neilstown is shown and labelled as 'old castle', suggesting that the castle was already of substantial age by the time of this map. It is shown in association with a second smaller structure which may represent the 16th/17th century house (DU017-032002).

### **Rocque's An Actual Survey of County Dublin, 1760**

Rocque's map of 1760 depicts a largely agricultural landscape with dispersed settlement. The Grand Canal is visible as 'New Canal'. A small demesne is present to the east called 'Cappoh'. A group of structures is shown at the location of the castle at Neilstown but the castle is not annotated. To the west, 'Castle Adams' is depicted which may correlate to the tower house (DU017-029) in Adamstown.

### **John Taylor's Map of the County of Dublin, 1816**

By the time of Taylor's map of 1816, the demesne at Cappagh is shown once more. A number of residences are also marked, including Springfield, immediately north of the Grand Canal, and Kishoge House. 'Castle Adams' is depicted once again possibly correlating to the tower house (DU017-029) in Adamstown. A number of locks are indicated along the Grand Canal to the south.

### **First Edition Ordnance Survey Map, 1843, scale 1:10,560 (Figure 3)**

The first edition OS map of 1843 is the first accurate depiction of the proposed development area. While much of the Clonburris SDZ lands remain agricultural in nature, a number of residences and small demesnes have been established. A small demesne associated with Clonburris Cottage is shown to the west of the proposed development site. Its grounds extend south towards the Grand Canal and a gate lodge is annotated immediately north of the towpath. Further to the west of Clonburris Cottage, a quarry is marked. There is no trace of either enclosure DU017-036 or DU017-035 within the SDZ lands. There are a number of small structures immediately north of the Grand Canal, which are likely to represent vernacular houses, accessed from the canal path.

### **Second Edition Ordnance Survey Map, 1871, scale 1:10,560**

There is little change by the time of this map, with the exception of the addition of the Great Southern and Western Railway, which opened in 1846 and runs immediately north of Tiles 2 and 3.

### **Ordnance Survey Map, 1906–9, scale 1:2,500**

There are no significant changes to the proposed development area depicted within this map.

### **Third Edition Ordnance Survey Map, 1937, scale 1:10,560 (Figure 3)**

There are no major changes to Tile 2 and Tile 3 notable within the cartography of this map.

## **2.4 SUMMARY OF GEOPHYSICAL RESULTS**

The geophysical survey, comprising high resolution magnetic gradiometry, was focused on five separate fields and covered an area of approximately 8ha both within Tiles 2 and 3 and in the immediate environs (Dowling 2022). Despite the poor ground conditions on site, the investigation revealed a number of features of potential archaeological significance. A semi-circular, positive anomaly may depict the eastern circuit of a small, sub-circular enclosure, measuring some 36m in diameter (north-south). This feature, may correspond to cropmark enclosure DU017-036, which appears to be bisected, east to west, by a possible ditch and is conceivably associated with several possible pits/spreads.

There is extensive evidence for past agricultural activity including a series of linear anomalies that appear to represent a relict field system/s delimited by ditches. Two of these, are potentially associated with former cultivation. Several very faint positive linear trends also hint at the potential presence of other ditches across the site; however, these are barely perceptible above the 'background' levels and their identification is highly tentative. A former watercourse is suggested by a possible paleochannel in Field 2, with modern activity not only indicated by ground disturbance and extensive ferrous litter, but also by a possible linear trench in Field 5.

## **2.5 AERIAL PHOTOGRAPHIC ANALYSIS**

An inspection of the aerial photography available has shown that the 1995 (OSI) shows a largely undeveloped area. By 2000, the Fonthill Road has been constructed and the R136 further west is under construction. The construction of the Clondalkin Fonthill Railway Station and associated car park is visible to the east in the aerial imagery of 2008 (Google Earth). A potential archaeological feature is present c. 300m southwest of the proposed development area, adjacent to the canal. This feature appears as a possible double ditched enclosure, with a diameter of c. 28m. The feature is only visible within the 2008 Google Earth coverage. This site was subsequently inspected and no obvious features of archaeological potential were noted and the anomaly may be due to disturbance of vegetation possibly caused by vehicles.

## **2.6 TOPOGRAPHICAL FILES**

Information on artefact finds from the study area in County Dublin has been recorded by the National Museum of Ireland since the late 19th century. Location information relating to these finds is important in establishing prehistoric and historic activity in the study area. Two stray finds have been discovered in the vicinity of the proposed development.

<b>MUSEUM NO</b>	1996:19 (83.17986111)
<b>FIND</b>	Palstave

---

<b>TOWNLAND</b>	Clonburris Little
<b>FIND PLACE</b>	OSW 52.3 OSS 12.6 - Surface find in cultivated field.
<b>DESCRIPTION</b>	Flanged Bronze Axehead in rather battered condition. Convex cutting edge dented in places; high, vertical convex flanges around base, with marked, straight stop ridge. Butt broken. L12.6, W6.4, T3.4
<b>REFERENCE</b>	NMI Topographical Files

<b>MUSEUM NO</b>	IA/163/1996 (83.09722222)
<b>FIND</b>	Axehead
<b>TOWNLAND</b>	Kishoge
<b>FIND PLACE</b>	705919,732611 - Metal detector
<b>DESCRIPTION</b>	Flat Bronze Axehead. Decorated. Possible Derryniggin type. Bronze disease covering both surfaces.
<b>REFERENCE</b>	NMI Topographical Files



### **3 ARCHAEOLOGICAL TESTING**

#### **3.1 GENERAL**

The initial programme of test trenching took place in November 2022, using hand tools (Plate 1) and a 13 tonne 360 degree tracked excavator equipped with a flat, toothless bucket under strict archaeological supervision. Any investigated deposits were preserved by record. This was by means of written, drawn and photographic records. The upcast spoil from the trenches was also subjected to metal detection under licence 22R0359 (Plate 2 and Plate 3).

A total of 10 trenches were excavated across Tiles 2 and 3, including six trenches excavated in Tile 2 and six trenches excavated in Tile 3. Trenches were placed to target geophysical anomalies and green space where geophysical survey was unable to reach. One trench (T9) was spilt to avoid an upstanding metal cap for a bore hole. Two test trenches in Tile 2 (originally Tile 3) were hand excavated in order to assess potential remains associated with recorded enclosure DU017-036.

In March 2023, following the issuing of an RFI, two additional hand dug trenches were excavated across the projected extent of the possible enclosure DU017-036, partially located within Tile 3. This report details the results of both investigations (Figure 4, Appendices 1 and 2).

The test trenches were excavated to determine, as far as reasonably possible, the location, extent, date, character, condition, significance and quality of any surviving archaeological remains threatened by proposed development in Tiles 2 and 3. Test trenching was also carried out to clarify the nature and extent of existing disturbance and intrusions and to assess the degree of archaeological survival in order to formulate further mitigation strategies. These are designed to reduce or offset the impact of the proposed development.

#### **3.2 METAL DETECTION RESULTS (22R0359)**

An Equinox 600 metal detector was utilised on the upcast spoil from all 14 test trenches. One metal item was recovered using this methodology from the north-eastern terminus of Trench 4. It possibly represents a decorative plate such as those seen on garden gates or possibly part of a set of scales (Plate 4). This item was found directly below the sod layer near the field surface.

#### **3.3 TESTING RESULTS TILE 2**

Topsoil consists of a soft greyish brown silty clay with 0.2–0.4m average depth with pieces of post-medieval pottery and metal recovered from it (Plates 5 and 6). Subsoil consists of a mottled grey clay with frequent small and moderate angular and sub-angular stones. A single piece of possible Dublin Ware was also recovered from the topsoil (Plate 7). The eastern portion of the development area was not tested due to the fact it has been subject to extensive ground disturbance in the past.

### **Archaeological Features**

One area of archaeological interest (AA) was in the site during the course of works within Tile 2 (Figure 4). This comprises the possible remains of enclosure DU017-036, which extends into Tile 3 to the west.

#### **AA1 (eastern section)**

AA1 was recorded in Trench 7 and 8 and consists of shallow linear features (C7.1 and C8.1) measuring between 1.52m and 2.05m wide and 0.4m to 0.48m deep (Plates 8–10; Figure 5). These features are filled by similar material in both trenches with the upper fill consisting of a compacted bright orange clay and the lower fill consisting of an orange clay with moderate amount of decayed stone present.

These features align with the curving geophysical anomaly identified at this location, which may relate to recorded monument DU017-036. The plotted location of this monument straddles both Tile 2 and 3, although the majority of the site is in Tile 2. Given the features have a maximum depth of 0.48m, which is relatively shallow for an enclosing feature, it is possible that the site has been subject to horizontal truncation.

### **Non-Archaeological Features**

A number of recent agricultural field drains and furrows were noted in Trenches 10 and 12 (Figure 4; Plate 13).

## **3.4 TESTING RESULTS TILE 3**

Topsoil consists of a soft greyish brown silty clay with 0.2–0.4m average depth. Subsoil consists of a mottled grey clay with frequent small and moderate angular and sub-angular stones.

### **Archaeological Features**

Two of archaeological interest (AA) was identified within Tile 3 during the course of these works (Figure 4).

#### **AA1 (western section)**

Trench 13 and 14 targeted the western projected extent of the possible enclosure DU017-036. One shallow linear feature was identified in Trench 13, which measured 1m in width and 0.48m deep (C13.1, Plate 10). Two fills were present, which differed slightly to those identified in Trenches 7 and 8. No features of archaeological potential were identified in Trench 14. It is possible that C13.1 relates to the enclosure site, but it may also relate to more recent agricultural activities.

#### **AA2**

AA2 was recorded in Trench 1 and consists of a metalled surface (C1.2) that was overlain by a spread of light brown clayey silt with an orange hue (C1.1) (Plate 14; Figure 5). This metalled surface possibly relates to farm buildings associated with Clonburris Cottage as depicted on the first edition Ordnance Survey map from 1843, c. 158m southwest of Tile 3. Although, no structures are shown in this area in any of the available historic maps.

### **Non-Archaeological Features**

A number of field drains and furrows were noted in Trenches 1, 5, and 6 (Figure 4).

### **3.5 CONCLUSIONS**

The area subject to archaeological testing is located in the townland of Cappagh, Clondalkin, Dublin 22, within the Clonburris SDZ, and includes two parcels of land, Tile 2 to the east and Tile 3 to the west. There is one recorded monument located within the tested areas (DU017-036) and there is one recorded monument (DU017-035), c. 300m to the southwest, both of which are listed as enclosures.

DU017-036 was identified from an aerial photograph taken in 1971, which shows a cropmark of an elongated oval enclosure (est. dims. NE-SW c. 34m; NW-SE c. 22m).

A geophysical survey was carried out within the proposed development area by Ger Dowling in June 2022 (Licence No. 22R0200). Gradiometer scanning identified responses indicative of a semi-circular feature that may depict the eastern circuit of a small, sub-circular enclosure, measuring c. 36m in diameter. This anomaly is thought to roughly correspond to the location of recorded monument DU017-0036 (Dowling 2022).

The eastern, larger portion of the possible enclosure is located in Tile 2, whereas the western, smaller section of the site is located within Tile 3.

Archaeological testing revealed two areas of archaeological potential, which have been designated as Archaeological Areas 1 and 2.

- AA1 (Tile 2 and 3): This consists of a number of shallow linear features identified in Trenches 7, 8 and 14, which align with the curving anomaly identified in the geophysical survey at the location of recorded monument DU017-0036. No diagnostic material was identified during testing and the remains cannot be definitively interpreted as an enclosure site. However, the site remains listed as a recorded monument and is subject to statutory protection under the National Monuments Act.
- AA2 (Tile 3): This consists of a metalled surface orientated northeast-southwest possibly associated with farm buildings.

## **4 IMPACT ASSESSMENT AND MITIGATION STRATEGY**

Impacts can be identified from detailed information about a project, the nature of the area affected and the range of archaeological resources potentially affected. Archaeological sites can be affected adversely in a number of ways: disturbance by excavation, topsoil stripping; disturbance by vehicles working in unsuitable conditions; and burial of sites, limiting access for future archaeological investigation.

### **4.1 IMPACT ASSESSMENT**

#### **Tile 2**

- Ground disturbances associated with the proposed development may have an adverse impact on the potential archaeological remains identified in Archaeological Area 1, which may relate to c. 80% of the recorded enclosure site DU017-036.
- Ground disturbances may have an adverse impact on previously unrecorded small or isolated archaeological features or deposits that have the potential to survive beneath the current ground level and outside the footprint of the excavated test trenches.

#### **Tile 3**

- Ground disturbances associated with the proposed development may have an adverse impact on the potential archaeological remains identified in Archaeological Area 1, which may relate to c. 20% of the recorded enclosure site DU017-036.
- Ground disturbances associated with the proposed development will have an adverse impact on the archaeological remains identified in Archaeological Area 2.
- Ground disturbances may have an adverse impact on previously unrecorded small or isolated archaeological features or deposits that have the potential to survive beneath the current ground level and outside the footprint of the excavated test trenches.

### **4.2 MITIGATION**

#### **Tile 2**

- It is acknowledged that the preservation in-situ of archaeological remains is the best form of long-term conservation; however, due to the layout and density requirements of the approved SDZ, it is not possible to facilitate the

preservation of AA1. Although the site is a recorded monument, no significant or diagnostic remains have been identified during testing. It is recommended that an area measuring c. 50m x 55m be opened around the possible enclosure DU017-0036 identified in Trenches 7, 8 and 13 (within the full extent of Tile 2) in order to facilitate its preservation by record (Archaeological Area 1). This should be carried out by an archaeologist under licence from the National Monuments Service of the DoHLGH.

- It is recommended that all topsoil stripping in Tile 2 (with the exception of the disturbed eastern extent) be monitored by a suitably qualified archaeologist. If any features of archaeological potential are discovered during the course of the works further archaeological mitigation may be required, such as preservation *in situ* or by record. Any further mitigation will require approval from the National Monuments Service of the DoHLGH.

### **Tile 3**

- It is recommended that the small section of AA1 within Tile 3 be preserved by record as part of the Tile 2 works (as per the above mitigation measures). This will enable the whole of the site to be preserved by record in one phase of works.
- It is recommended that an area measuring c. 10m x 10m be opened around the metallised surface found in Trench 1 in order to facilitate its preservation by record (Archaeological Area 2) with further monitoring to establish the total length. All works should be carried out by an archaeologist under licence to the National Monuments Service of the DoHLGH.
- It is recommended that all topsoil stripping in Tile 3 be monitored by a suitably qualified archaeologist. If any features of archaeological potential are discovered during the course of the works further archaeological mitigation may be required, such as preservation *in situ* or by record. Any further mitigation will require approval from the National Monuments Service of the DoHLGH.

*It is the developer's responsibility to ensure full provision is made available for the resolution of any archaeological remains, both on site and during the post excavation process, should that be deemed the appropriate manner in which to proceed.*

**Please note that all recommendations are subject to approval by the National Monuments Service of the Heritage and Planning Division, Department of Housing, Local Government and Heritage.**

## 5 REFERENCES

- Byrne, F. J. 1973. *Irish Kings and High Kings*. Dublin. Four Courts Press.
- Chartered Institute for Archaeologists. 2020a. *Standards & Guidance for Field Evaluation*.
- Chartered Institute for Archaeologists. 2020b. *Standards & Guidance for Archaeological Excavation*.
- Chartered Institution of Field Archaeologists. 2020c. *Standards & Guidance for an Archaeological Watching Brief (Monitoring)*.
- Department of Arts, Heritage, Gaeltacht and the Islands. 1999a. *Framework and Principles for the Protection of the Archaeological Heritage*. Government Publications Office, Dublin.
- Department of Arts, Heritage, Gaeltacht and the Islands. 1999b. *Policy and Guidelines on Archaeological Excavation*. Government Publications Office, Dublin.
- Dowd, M. and Carden, R.F. 2016. First evidence of a Late Upper Palaeolithic human presence in Ireland. *Quaternary Science Reviews* 139, 158-163.
- Dowling, G. 2022. Geophysical Survey Report Cappagh (Clondalkin), Dublin 22. Licence No. 22R0200. Unpublished report prepared for IAC Archaeology.
- Environmental Protection Agency. 2017. *Draft Advice Notes on Current Practice (in the preparation of Environmental Impact Statements)*. Government Publications Office, Dublin.
- Environmental Protection Agency. 2022. *Guidelines on the Information to be Contained in Environmental Impact Statements*. Government Publications Office, Dublin.
- MacCotter, P. 2008. *Medieval Ireland: Territorial, Political and Economic Divisions*. Dublin. Four Courts Press.
- Murtagh, F. 2022. Archaeological Assessment at Clonburris Little, Cappagh, Kishoge, and Grange, Clondalkin Dublin 22 (Clonburris Strategic Development Zone). Licence No. 20E0438. Unpublished report prepared by IAC Archaeology.
- Murtagh, F. 2022. Archaeological Assessment at Cappagh, Clonburris Little and Kishogue, Dublin 22. Licence No. 22E0438. Unpublished report prepared by IAC Archaeology.
- National Monuments Service, Department of Culture, Heritage and the Gaeltacht. *Sites and Monuments Record, County Dublin*.
- National Museum of Ireland. *Topographical Files, County Dublin*.
- O' Neill, J. 2020. Archaeological Assessment at Clonburris Little, Cappagh, Kishoge, and Grange, Clondalkin Dublin 22 (Clonburris Strategic Development Zone). Licence Nos. 20E0390 and 20R0168. Unpublished report prepared by IAC Archaeology.
- O'Neill J, Piera M, & Hanbidge R. 2021. Archaeological assessment at Fonthill Road north/Lucan Newlands Road, Cappagh, Clonburris, Dublin 22 (Clonburris Strategic Development Zone) Licence No. 21E0084. Unpublished report prepared by IAC Archaeology.
- Quinn, B., & Moore, D. 2009 'Fulacht fiadh' and the beer experiment' in Stanley et al (eds) *Dining & Dwelling*. NRA Monograph Series No. 6, 43-53, NRA, Dublin.
- Stout, M. 2017. *Early Medieval Ireland 431-1169*. Dublin. Wordwell Ltd.

Stout, G. and Stout, M. 1997. Early Landscapes: from Prehistory to Plantation. In F.H.A. Aalen et al. (ed.), *Atlas of the Irish Rural Landscape*. Cork. Cork University Press.

### **CARTOGRAPHIC SOURCES**

Sir William Petty, *Down Survey Map of the Barony of Newcastle* c. 1655

Rocque's *An Actual Survey of County Dublin*, 1760

John Taylor's *Map of the County of Dublin*, 1816

Ordnance Survey maps of County Dublin 1843, 1871, 1906–09, and 1937.

### **ELECTRONIC SOURCES**

[www.excavations.ie](http://www.excavations.ie) – Summary of archaeological excavation from 1970–2022.

O'Kelly, M. J. 1954. Excavations and Experiments in Ancient Irish Cooking-Places. *The Journal of the Royal Society of Antiquaries of Ireland*, 84(2), 105–155.

<http://www.jstor.org/stable/25509173> (accessed 2 December 2022)

Nelis D, 2017. Letts Field, Neillstown, Clondalkin, Dublin 22, Dublin. *Excavations.ie*: Database of Irish excavation summaries

(<https://excavations.ie/report/2017/Dublin/0026249/>; accessed 4 December 2022)

NMS 2014 DU017-036 Cappagh. National Monuments Service Historic Environment Viewer. (<http://webgis.archaeology.ie/historicenvironment/>; accessed 4 December 2022).

[www.heritagemaps.ie](http://www.heritagemaps.ie) – The Heritage Council web-based spatial data viewer which focuses on the built, cultural and natural heritage around Ireland and off shore.

[www.googleearth.com](http://www.googleearth.com) – Satellite coverage of the proposed development area

[www.bingmaps.com](http://www.bingmaps.com) – Satellite coverage of the proposed development area

## APPENDICES

### APPENDIX 1 TRENCH RESULTS

#### Tile 2

TRENCH	LENGTH (m)	WIDTH (m)	DEPTH (m)	ORIENTATION	DETAILS
7	10	1	0.3–0.4	North–South	A shallow linear feature (C7.1) with a gradual break of slope at top gently sloping sides and a concave base. It measured 1.52m in width and 0.4m in depth. The upper fill (C7.2) consists of a compacted bright orange clay. It is 0.2m deep. The lower fill (C7.3) consists of an orange clay with moderate amount of decayed stone present. A curvilinear geophysical anomaly was targeted in this trench possibly corresponding to DU017-0036. Plate 8, Figures 4 and 5.
8	10	1	0.35–0.4	Northwest–Southeast	A shallow linear feature (C8.1) with a gradual break of slope at top gently sloping sides and a concave base. It measured 2.05m in width and 0.48m in depth. The upper fill (C8.2) consists of a compacted bright orange clay. It is 0.23m deep. The lower fill (C8.3) consists of an orange clay with moderate amount of decayed stone present. It is 0.25m deep. A curvilinear geophysical anomaly was targeted in this trench possibly corresponding to DU017-0036. Plate 8, Figures 4 and 5.
9	20	2	0.4–0.5	West–East	No archaeology found. Trench 9 was spilt to avoid an upstanding metal cap for a bore hole. No geophysical anomalies targeted. Plate 18
10	80	2	0.36–0.7	West–East	No Archaeology found. A linear geophysical anomaly and a separate large anomaly was targeted here. These corresponded to a pipe and some plastic debris on the field surface
11	90	2	0.3–0.8	North–South	No Archaeology found. No geophysical anomalies targeted. Plate 19
12	100	2	0.4–0.5	North–South	No Archaeology found. No geophysical anomalies targeted. Three field drains were noted crossing the trench on a northwest–southeast orientation Plate 20

#### Tile 3

TRENCH	LENGTH (m)	WIDTH (m)	DEPTH (m)	ORIENTATION	DETAILS
1	40	2	0.3–0.5	West–East	A linear spread (C1.1) orientated northeast–southwest consisting of a light brown clayey silt with an orange hue was recorded within Trench 1. It measured 2.3m in width and 0.12m maximum depth. This overlays a metallised surface (C1.2) which consists of tightly packed sub-angular stone (Plate 14). It measures 2.3m in width and 0.05m in



TRENCH	LENGTH (m)	WIDTH (m)	DEPTH (m)	ORIENTATION	DETAILS
					depth. Plate 15, Figure 5. No geophysical anomalies targeted.
2	90	2	0.5–0.8	Northwest–Southeast	No Archaeology found. A curvilinear geophysical anomaly was targeted.
3	40	2	0.3–0.7	Northwest–Southeast	No Archaeology found. A curvilinear geophysical anomaly was targeted.
4	40	2	0.3–0.4	North-northeast–South-southwest	No Archaeology found. A large geophysical anomaly was targeted. A metal object (Plate 4) was recovered here under licence 22R0359 directly below the sod layer. Plate 16
5	90	2	0.3–0.5	Northeast–Southwest	No Archaeology found. A number of probable field drains and small geophysical anomalies were targeted. Plate 17
6	40	2	0.5	North–South	No Archaeology found. No geophysical anomalies targeted.
13	10	1.1	0.5	East–west	A shallow linear feature (C13.1) with a gradual break of slope at top steep sloping sides and a concave base. It measured 1m in width and 0.48m in depth. The upper fill (C13.2) consists of a grey to yellow clay with flecks of charcoal. It is 1m in width and 0.17m deep. The lower fill (C13.3) consists of a grey clay with flecks of charcoal present. It is 0.86m in width and 0.31m deep (Plate 10). The projected line of a curvilinear geophysical anomaly was targeted in this trench possibly corresponding to DU017-036. Plate 11, Figures 4 and 5.
14	10	1.1	0.6	East–west	No Archaeology found. The projected line of a curvilinear geophysical anomaly was targeted Plate 12.

## APPENDIX 2 CONTEXTS

### Tile 2

CONTEXT NO.	TRENCH NO.	DESCRIPTION
C7.1	7	A shallow linear feature with a gradual break of slope at top, gently sloping sides, with a gradual almost imperceptible break of slope at a concave base.
C7.2	7	The upper fill consists of a compacted bright orange clay.
C7.3	7	The lower fill consists of an orange clay with moderate amount of decayed stone present.
C8.1	8	A shallow linear feature with a gradual break of slope at top gently sloping sides and a concave base.
C8.2	8	The upper fill consists of a compacted bright orange clay.
C8.3	8	The lower fill consists of an orange clay with moderate amount of decayed stone present.

### Tile 3

CONTEXT NO.	TRENCH NO.	DESCRIPTION
C1.1	1	A linear spread orientated northeast–southwest consisting of a light brown clayey silt with an orange hue
C1.2	1	A metallated surface which consists of tightly packed sub-angular stone.
C13.1	13	A shallow linear feature with a gradual break of slope at top steep sloping sides and a concave base. It measured 1m in width and 0.48m in depth
C13.2	13	Upper fill of C13.1 consisting of a grey to yellow clay with flecks of charcoal. It is 1m in width and 0.17m deep.
C13.3	13	Lower fill C13.1 consisting of a grey clay with flecks of charcoal present. It is 0.86m in width and 0.31m deep

## APPENDIX 3 FINDS LIST

### Tile 2

CONTEXT	FULL NAME	MATERIAL	DESCRIPTION
C7.1	Post medieval pottery	Ceramic	Nine assorted pieces of post medieval/modern pottery
C7.1	Glass ware	Glass	One piece of post medieval/modern decorative glass
C7.1	Metal	Iron	Two small pieces of iron, one possible wire the other a flat piece
C8.1	Post medieval pottery	Ceramic	Eight assorted pieces of post medieval/modern pottery
C8.1	Dublin ware	Ceramic	One possible piece of Dublin ware type pottery

### Tile 3

CONTEXT	FULL NAME	MATERIAL	DESCRIPTION
C4.1	Metal plate	Iron	A flat metal plate with a hook at either end. Very flat and smooth on one side but with a fixed metal (possibly decorative) element on the opposing side

#### APPENDIX 4 RMP SITES WITHIN THE SURROUNDING AREA

<b>SMR NO.:</b>	DU017-036
<b>RMP STATUS:</b>	Yes
<b>TOWNLAND:</b>	Cappagh
<b>PARISH:</b>	Clondalkin
<b>BARONY:</b>	Uppercross
<b>I.T.M.:</b>	705829, 732593
<b>CLASSIFICATION:</b>	Enclosure
<b>DIST. TO SITE:</b>	0m
<b>DESCRIPTION:</b>	Situated in rough pasture on fairly level ground north of a stream. An aerial photograph taken in 1971 (FSI 206/5/4) shows a cropmark of an elongated oval enclosure (est. dims. northeast–southwest c. 34m; northwest–southeast c. 22m). Not visible at ground level.
<b>REFERENCE:</b>	<a href="http://www.archaeology.ie/">www.archaeology.ie/</a> SMR file

<b>SMR NO.:</b>	DU017-035
<b>RMP STATUS:</b>	Yes
<b>TOWNLAND:</b>	Clonburris little
<b>PARISH:</b>	Clondalkin
<b>BARONY:</b>	Uppercross
<b>I.T.M.:</b>	705412, 732276
<b>CLASSIFICATION:</b>	Enclosure
<b>DIST. TO SITE:</b>	c. 300m to the southwest
<b>DESCRIPTION:</b>	In field of rough pasture bordering the canal. An aerial photograph (FSI 1971/224-6) shows a horseshoe-shaped enclosure. Not visible at ground level.
<b>REFERENCE:</b>	<a href="http://www.archaeology.ie/">www.archaeology.ie/</a> SMR file

## **APPENDIX 5 LEGISLATION PROTECTING THE ARCHAEOLOGICAL RESOURCE**

### **PROTECTION OF CULTURAL HERITAGE**

The cultural heritage in Ireland is safeguarded through national and international policy designed to secure the protection of the cultural heritage resource to the fullest possible extent (Department of Arts, Heritage, Gaeltacht and the Islands 1999, 35). This is undertaken in accordance with the provisions of the *European Convention on the Protection of the Archaeological Heritage* (Valletta Convention), ratified by Ireland in 1997.

### **THE ARCHAEOLOGICAL RESOURCE**

The *National Monuments Act 1930 to 2014* and relevant provisions of the *National Cultural Institutions Act 1997* are the primary means of ensuring the satisfactory protection of archaeological remains, which includes all man-made structures of whatever form or date except buildings habitually used for ecclesiastical purposes. A National Monument is described as 'a monument or the remains of a monument the preservation of which is a matter of national importance by reason of the historical, architectural, traditional, artistic or archaeological interest attaching thereto' (National Monuments Act 1930 Section 2). A number of mechanisms under the National Monuments Act are applied to secure the protection of archaeological monuments. These include the Register of Historic Monuments, the Record of Monuments and Places, and the placing of Preservation Orders and Temporary Preservation Orders on endangered sites.

### **OWNERSHIP AND GUARDIANSHIP OF NATIONAL MONUMENTS**

The Minister may acquire national monuments by agreement or by compulsory order. The state or local authority may assume guardianship of any national monument (other than dwellings). The owners of national monuments (other than dwellings) may also appoint the Minister or the local authority as guardian of that monument if the state or local authority agrees. Once the site is in ownership or guardianship of the state, it may not be interfered with without the written consent of the Minister.

### **REGISTER OF HISTORIC MONUMENTS**

Section 5 of the 1987 Act requires the Minister to establish and maintain a Register of Historic Monuments. Historic monuments and archaeological areas present on the register are afforded statutory protection under the 1987 Act. Any interference with sites recorded on the register is illegal without the permission of the Minister. Two months' notice in writing is required prior to any work being undertaken on or in the vicinity of a registered monument. The register also includes sites under Preservation Orders and Temporary Preservation Orders. All registered monuments are included in the Record of Monuments and Places.

### **PRESERVATION ORDERS AND TEMPORARY PRESERVATION ORDERS**

Sites deemed to be in danger of injury or destruction can be allocated Preservation Orders under the 1930 Act. Preservation Orders make any interference with the site

illegal. Temporary Preservation Orders can be attached under the 1954 Act. These perform the same function as a Preservation Order but have a time limit of six months, after which the situation must be reviewed. Work may only be undertaken on or in the vicinity of sites under Preservation Orders with the written consent, and at the discretion, of the Minister.

### **RECORD OF MONUMENTS AND PLACES**

Section 12(1) of the 1994 Act requires the Minister for Arts, Heritage, Gaeltacht and the Islands (now the Minister for Housing, Local Government and Heritage) to establish and maintain a record of monuments and places where the Minister believes that such monuments exist. The record comprises a list of monuments and relevant places and a map/s showing each monument and relevant place in respect of each county in the state. All sites recorded on the Record of Monuments and Places receive statutory protection under the National Monuments Act 1994. All recorded monuments on the proposed development site are represented on the accompanying maps.

Section 12(3) of the 1994 Act provides that 'where the owner or occupier (other than the Minister for Arts, Heritage, Gaeltacht and the Islands) of a monument or place included in the Record, or any other person, proposes to carry out, or to cause or permit the carrying out of, any work at or in relation to such a monument or place, he or she shall give notice in writing to the Minister of Arts, Heritage, Gaeltacht and the Islands to carry out work and shall not, except in case of urgent necessity and with the consent of the Minister, commence the work until two months after giving of notice'.

Under the National Monuments (Amendment) Act 2004, anyone who demolishes or in any way interferes with a recorded site is liable to a fine not exceeding €3,000 or imprisonment for up to 6 months. On summary conviction and on conviction of indictment, a fine not exceeding €10,000 or imprisonment for up to 5 years is the penalty. In addition, they are liable for costs for the repair of the damage caused.

In addition to this, under the *European Communities (Environmental Impact Assessment) Regulations 1989*, Environmental Impact Statements (EIS) are required for various classes and sizes of development project to assess the impact the proposed development will have on the existing environment, which includes the cultural, archaeological and built heritage resources. These document's recommendations are typically incorporated into the conditions under which the proposed development must proceed, and thus offer an additional layer of protection for monuments which have not been listed on the RMP.

### **THE PLANNING AND DEVELOPMENT ACT 2000**

Under planning legislation, each local authority is obliged to draw up a Development Plan setting out their aims and policies with regard to the growth of the area over a five-year period. They cover a range of issues including archaeology and built heritage, setting out their policies and objectives with regard to the protection and enhancement of both. These policies can vary from county to county. The Planning and Development Act 2000 recognises that proper planning and sustainable

development includes the protection of the archaeological heritage. Conditions relating to archaeology may be attached to individual planning permissions.

## **APPENDIX 6 IMPACT ASSESSMENT & THE CULTURAL HERITAGE RESOURCE**

### **POTENTIAL IMPACTS ON ARCHAEOLOGICAL AND HISTORICAL REMAINS**

Impacts are defined as 'the degree of change in an environment resulting from a development' (Environmental Protection Agency 2003: 31). They are described as profound, significant or slight impacts on archaeological remains. They may be negative, positive or neutral, direct, indirect or cumulative, temporary or permanent.

Impacts can be identified from detailed information about a project, the nature of the area affected and the range of archaeological and historical resources potentially affected. Development can affect the archaeological and historical resource of a given landscape in a number of ways.

- Permanent and temporary land-take, associated structures, landscape mounding, and their construction may result in damage to or loss of archaeological remains and deposits, or physical loss to the setting of historic monuments and to the physical coherence of the landscape.
- Archaeological sites can be affected adversely in a number of ways: disturbance by excavation, topsoil stripping and the passage of heavy machinery; disturbance by vehicles working in unsuitable conditions; or burial of sites, limiting accessibility for future archaeological investigation.
- Hydrological changes in groundwater or surface water levels can result from construction activities such as de-watering and spoil disposal, or longer-term changes in drainage patterns. These may desiccate archaeological remains and associated deposits.
- Visual impacts on the historic landscape sometimes arise from construction traffic and facilities, built earthworks and structures, landscape mounding and planting, noise, fences and associated works. These features can impinge directly on historic monuments and historic landscape elements as well as their visual amenity value.
- Landscape measures such as tree planting can damage sub-surface archaeological features, due to topsoil stripping and through the root action of trees and shrubs as they grow.
- Ground consolidation by construction activities or the weight of permanent embankments can cause damage to buried archaeological remains, especially in colluviums or peat deposits.
- Disruption due to construction also offers in general the potential for adversely affecting archaeological remains. This can include machinery, site offices, and service trenches.

*Although not widely appreciated, positive impacts can accrue from developments. These can include positive resource management policies, improved maintenance and access to archaeological monuments, and the increased level of knowledge of a site or historic landscape as a result of archaeological assessment and fieldwork.*

### **PREDICTED IMPACTS**

The severity of a given level of land-take or visual intrusion varies with the type of monument, site or landscape features and its existing environment. Severity of impact can be judged taking the following into account:

- The proportion of the feature affected and how far physical characteristics fundamental to the understanding of the feature would be lost;
- Consideration of the type, date, survival/condition, fragility/vulnerability, rarity, potential and amenity value of the feature affected;
- Assessment of the levels of noise, visual and hydrological impacts, either in general or site-specific terms, as may be provided by other specialists.



## **APPENDIX 7 MITIGATION MEASURES & THE CULTURAL HERITAGE RESOURCE**

### **POTENTIAL MITIGATION STRATEGIES FOR CULTURAL HERITAGE REMAINS**

Mitigation is defined as features of the design or other measures of the proposed development that can be adopted to avoid, prevent, reduce or offset negative effects.

The best opportunities for avoiding damage to archaeological remains or intrusion on their setting and amenity arise when the site options for the development are being considered. Damage to the archaeological resource immediately adjacent to developments may be prevented by the selection of appropriate construction methods. Reducing adverse effects can be achieved by good design, for example by screening historic buildings or upstanding archaeological monuments or by burying archaeological sites undisturbed rather than destroying them. Offsetting adverse effects is probably best illustrated by the full investigation and recording of archaeological sites that cannot be preserved *in situ*.

### **DEFINITION OF MITIGATION STRATEGIES**

#### **ARCHAEOLOGICAL RESOURCE**

The ideal mitigation for all archaeological sites is preservation *in situ*. This is not always a practical solution, however. Therefore, a series of recommendations are offered to provide ameliorative measures where avoidance and preservation *in situ* are not possible.

*Full Archaeological Excavation* involves the scientific removal and recording of all archaeological features, deposits and objects to the level of geological strata or the base level of any given development. Full archaeological excavation is recommended where initial investigation has uncovered evidence of archaeologically significant material or structures and where avoidance of the site is not possible. (ClfA 2020b)

*Archaeological Test Trenching* can be defined as 'a limited programme... of intrusive fieldwork which determines the presence or absence of archaeological features, structures, deposits, artefacts or ecofacts within a specified area or site on land or underwater. If such archaeological remains are present test trenching defines their character and extent and relative quality.' (ClfA 2020a)

*Archaeological Monitoring* can be defined as a 'formal programme of observation and investigation conducted during any operation carried out for non-archaeological reasons within a specified area or site on land or underwater, where there is possibility that archaeological deposits may be disturbed or destroyed. The programme will result in the preparation of a report and ordered archive.' (ClfA 2020c)

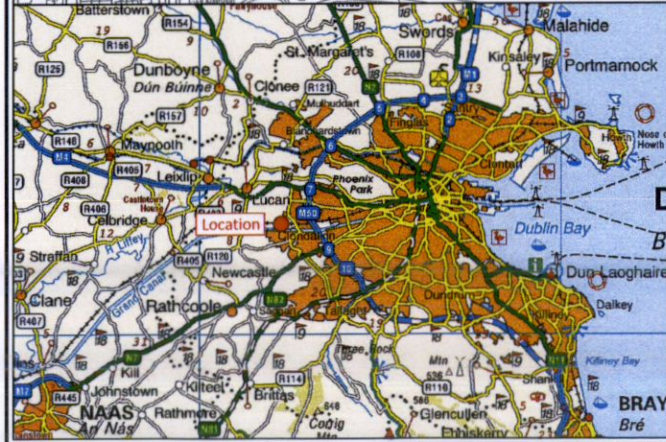
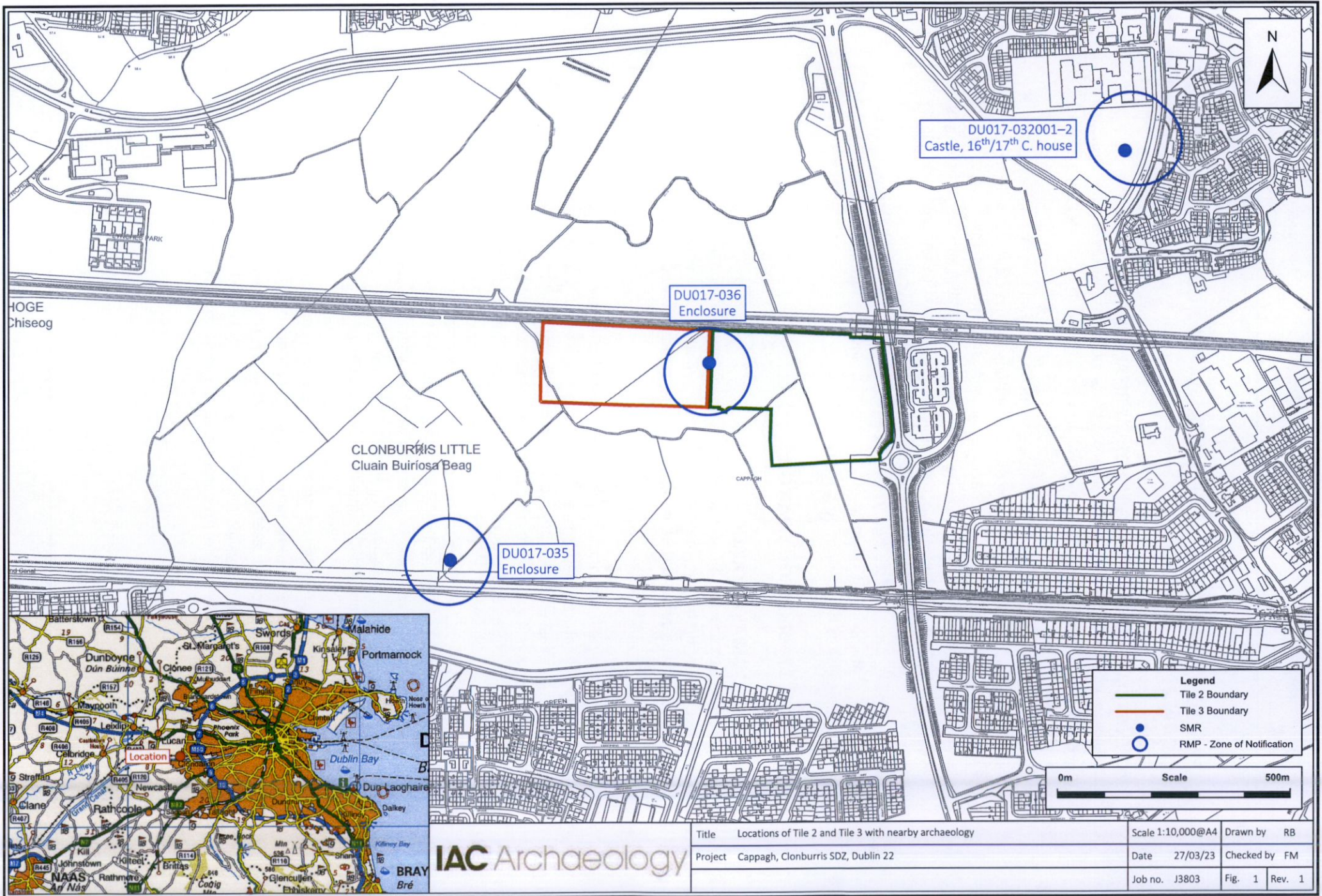

IAC Archaeology

Title	Locations of Tile 2 and Tile 3 with nearby archaeology	Scale	1:10,000@A4	Drawn by	RB
Project	Cappagh, Clonburris SDZ, Dublin 22	Date	27/03/23	Checked by	FM
		Job no.	J3803	Fig.	1
				Rev.	1



**Legend**  
 — Tile 2 Boundary  
 — Tile 3 Boundary

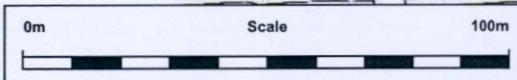

IAC Archaeology

Title	Plan of proposed development in Tile 2	Scale	1:1500@A4	Drawn by	RB
Project	Cappagh, Clonburris SDZ, Dublin 22	Date	27/03/23	Checked by	FM
		Job no.	J3803	Fig.	2a
				Rev.	1



TRAIN LINE

LOCAL GREEN CORRIDOR

STREET 13

PHASE T2  
INDICATIVE  
LAYOUT

PHASE 1  
REG REF -  
SDZ21A0022

VEHICULAR BRIDGE - SUBJECT OF FUTURE APPLICATION

LVL 67.3



LVL 67.2

CYCLE LINK

TCS  
1004E  
0471

BLOCK 1  
63-97

CCG  
322 sign

Legend	
	Tile 2 Boundary
	Tile 3 Boundary

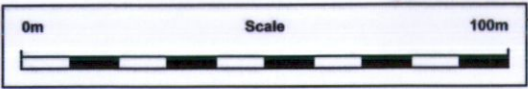

IAC Archaeology

Title	Plan of proposed development in Tile 3	Scale	1:1500@A4	Drawn by	RB
Project	Cappagh, Clonburris SDZ, Dublin 22	Date	27/03/23	Checked by	FM
Job no.	J3803	Fig.	2b	Rev.	1

First edition Ordnance Survey, 1843

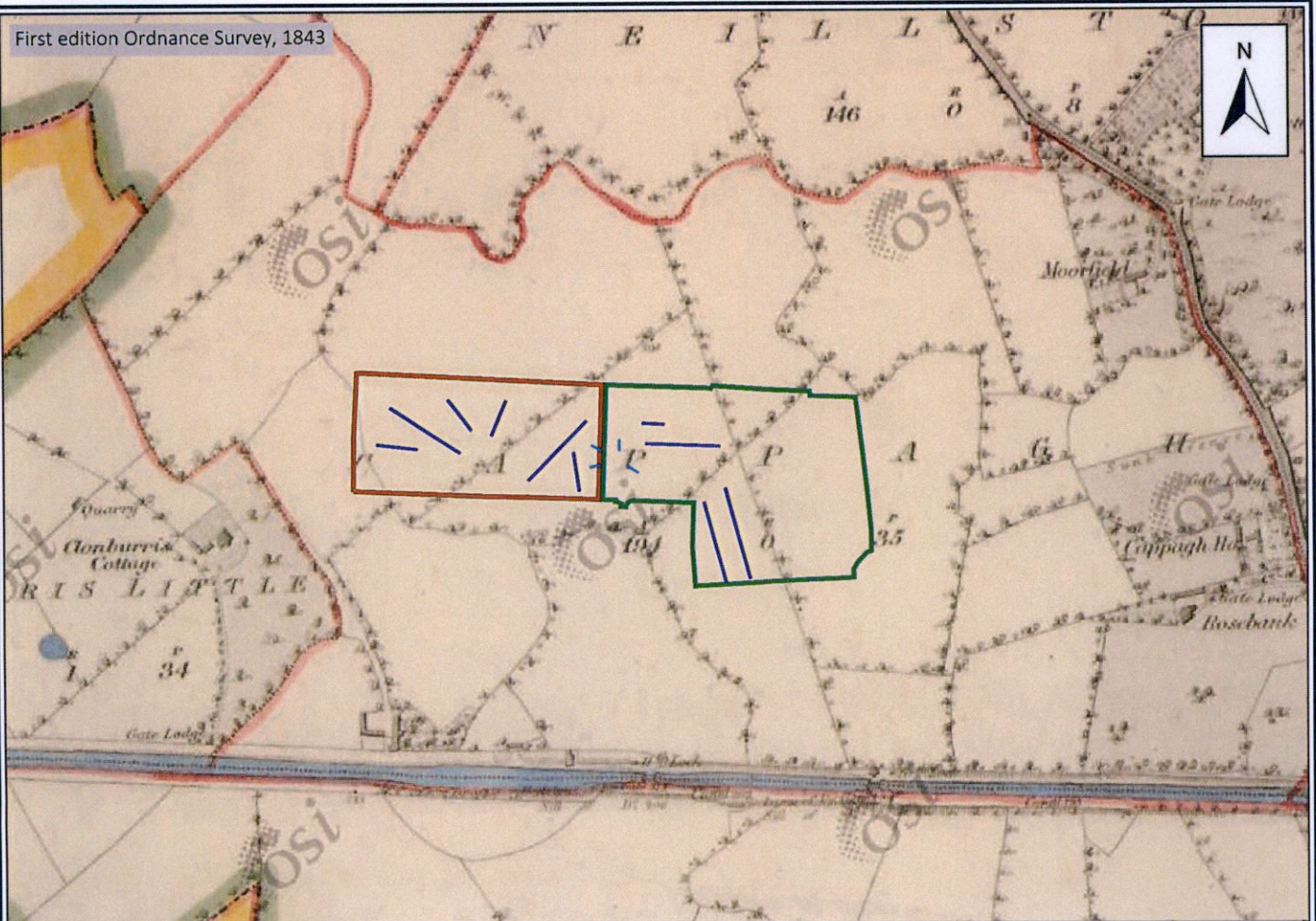

Third edition Ordnance Survey, 1935

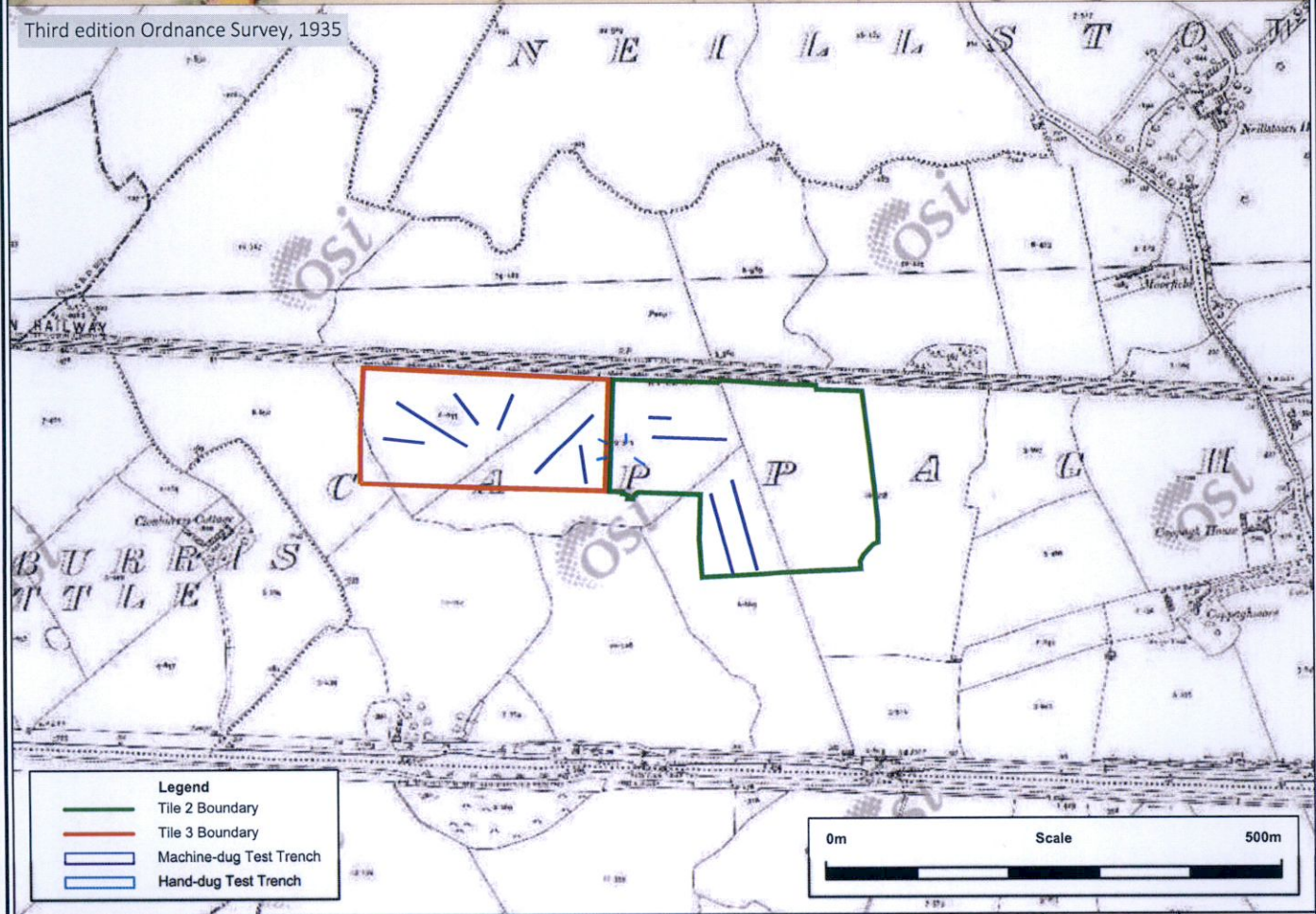

**Legend**

- Tile 2 Boundary
- Tile 3 Boundary
- ▨ Machine-dug Test Trench
- ▨ Hand-dug Test Trench

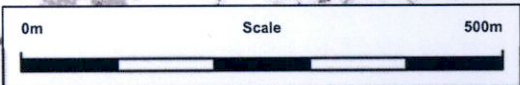

**IAC Archaeology**

Title	Extract from historic OS maps (1843 and 1937) showing Tile 2 and Tile 3	Scale	1:7500@A4	Drawn by	RB
Project	Cappagh, Clonburris SDZ, Dublin 22	Date	27/03/23	Checked by	FM
		Job no.	J3803	Fig.	3
				Rev.	1



+ 705550 E  
732700 N

+ 706100 E  
732700 N

+ 706100 E  
732400 N



- Geophysics Legend**
- Survey area
  - ?Archaeology
  - Relict Field boundary
  - Positive trend
  - Plough trend
  - ?Palaeochannel
  - ?Modern trench
  - Ferrous response
  - Magnetic disturbance

- Legend**
- Tile 2 Boundary
  - Tile 3 Boundary
  - Archaeological Area
  - Machine-dug Test Trench
  - Hand-dug Test Trench
  - XXXXXX E  
XXXXXX N  
ITM Reference

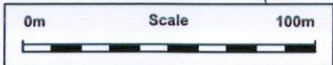

CAPPAGH

**IAC Archaeology**

Title	Test trench results	Scale	1:2500@A4	Drawn by	RB
Project	Cappagh, Clonburris SDZ, Dublin 22	Date	27/03/23	Checked by	FM
Job no.	J3803	Fig.	4	Rev.	1

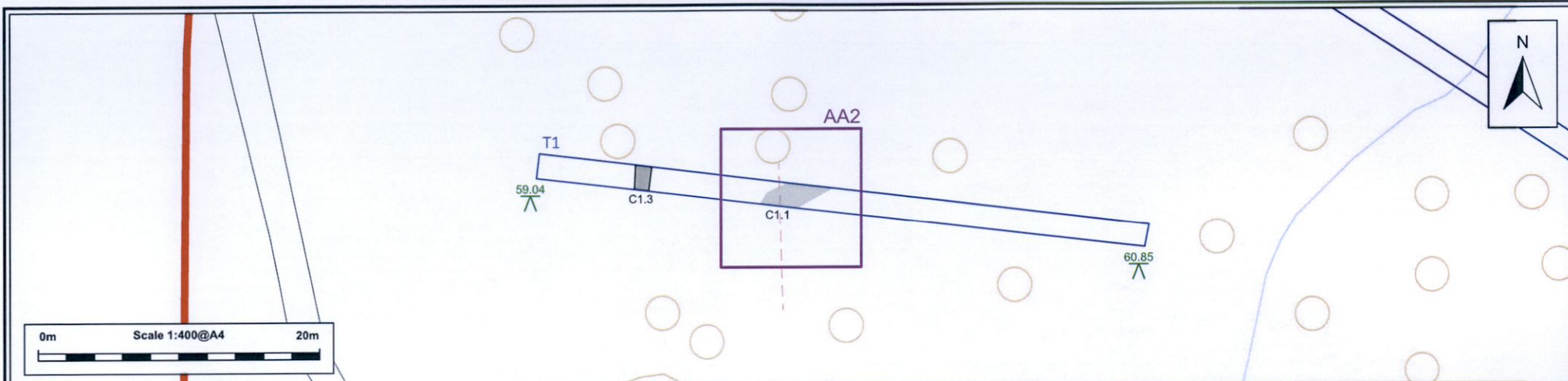

- Geophysics Legend**
- Survey area
  - ?Archaeology
  - Relict Field boundary
  - - - Positive trend
  - - - Plough trend
  - ?Palaeochannel
  - ?Modern trench
  - Ferrous response
  - Magnetic disturbance

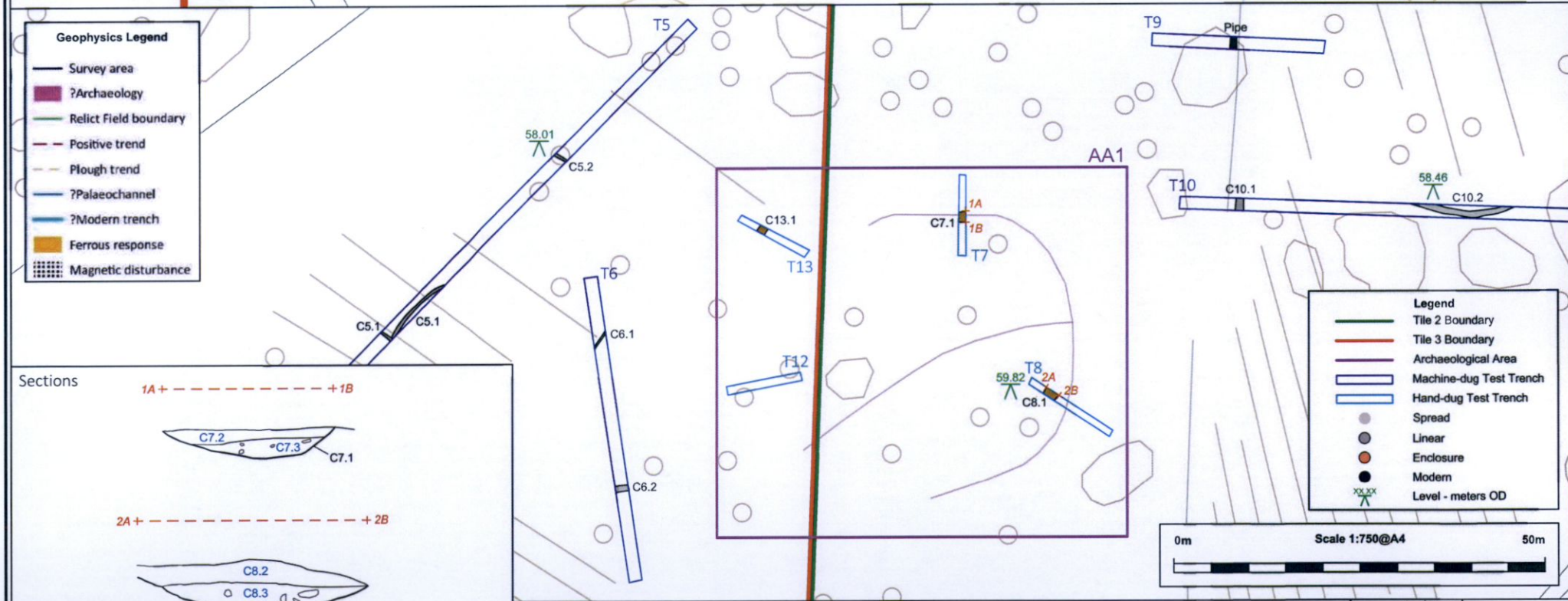

- Legend**
- Tile 2 Boundary
  - Tile 3 Boundary
  - Archaeological Area
  - Machine-dug Test Trench
  - Hand-dug Test Trench
  - Spread
  - Linear
  - Enclosure
  - Modern
  - xx Level - meters OD

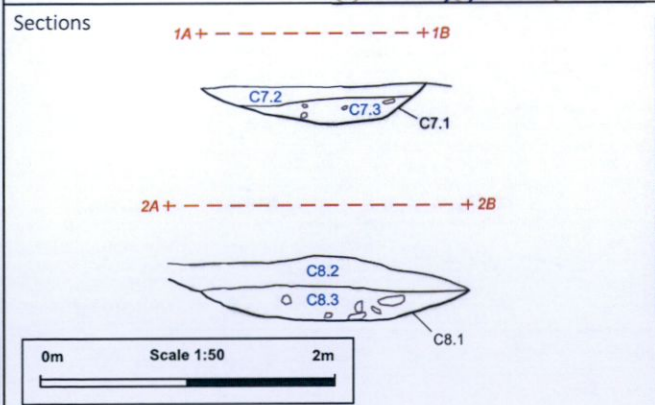

IAC Archaeology

Title	Detail view of Archaeological Areas	Scale	As shown @A4	Drawn by	RB
Project	Cappagh, Clonburris SDZ, Dublin 22	Date	27/03/23	Checked by	FM
Job no.	J3803	Fig.	5	Rev.	1



Plate 1 Trench 7, hand excavation, facing northeast



Plate 2 Trench 8, mid-excitation with metal detection ongoing facing west



Plate 3 Trench 13, metal detection of topsoil, facing west

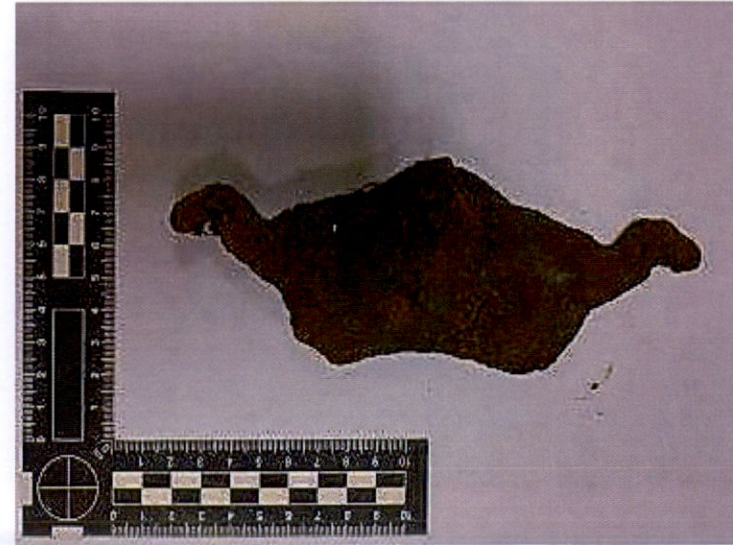

Plate 4 Metal object recovered through metal detection (22R0359)





Plate 5 Topsoil finds recovered from Trench 7



Plate 6 Topsoil finds recovered from Trench 8



Plate 7 Possible Dublin ware recovered from Trench 8 topsoil



Plate 8 Mid-excavation of linear feature C7.1, facing east



Plate 9 Mid-excavation view of linear feature C8.1, facing northeast

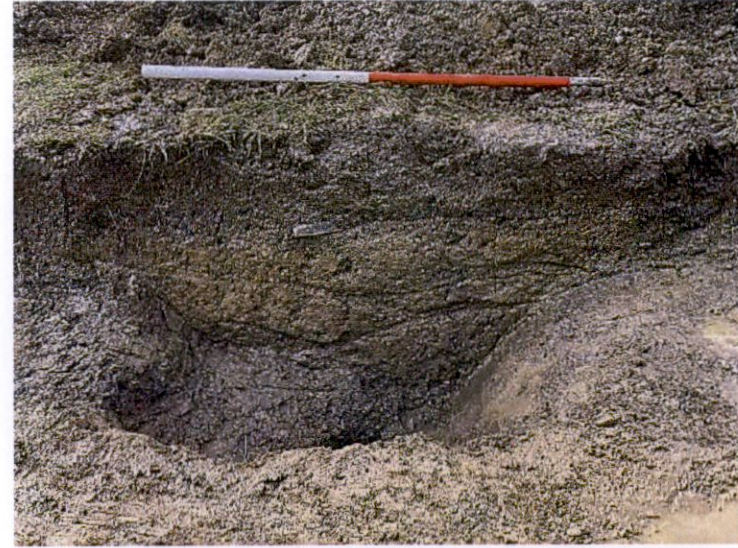

Plate 10 Mid-excavation view of linear feature C13.1, facing southwest



Plate 11 Trench 13, post-excavation facing west



Plate 12 Trench 14, post-excavation, facing east

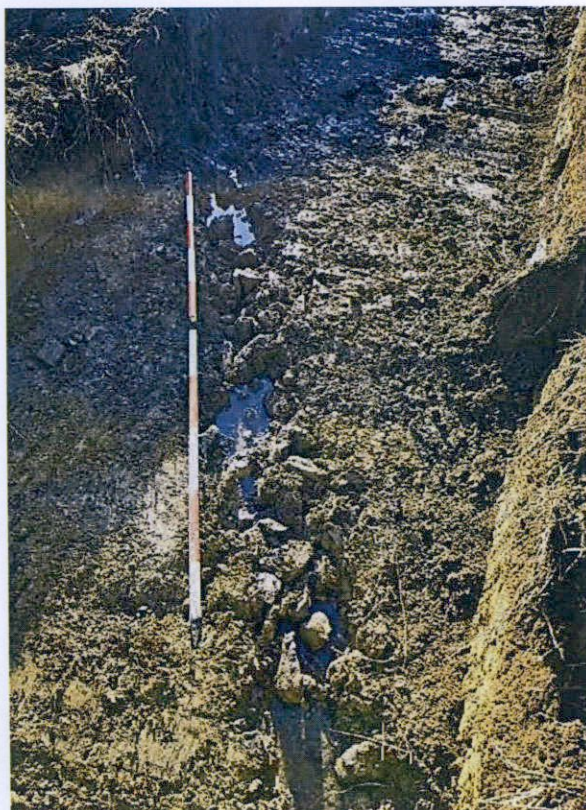

Plate 13 Modern field drain within Trench 12, facing southeast



Plate 14 Metallised surface C1.2 below spread C1.1, facing east



Plate 15 Trench 1, post-excavation facing west

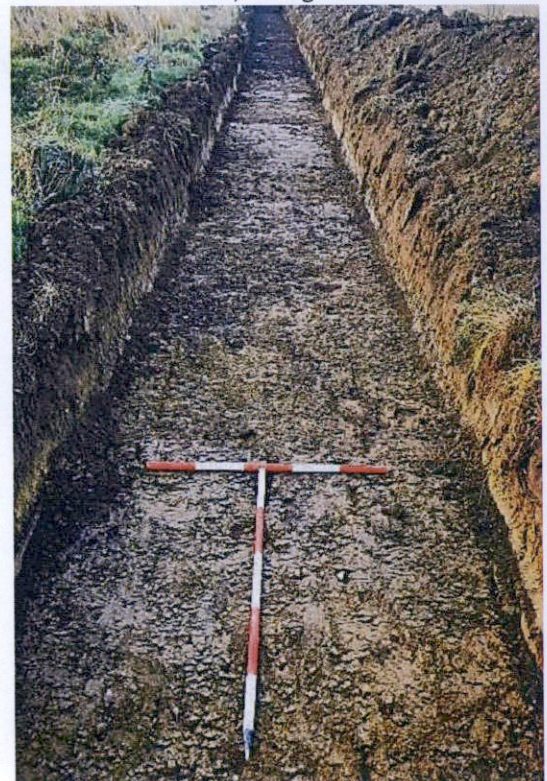

Plate 16 Trench 4, post-excavation facing south



Plate 17 Trench 5, post-excitation facing southwest



Plate 18 Trench 9, post-excitation facing west



Plate 19 Trench 11, post-excitation, facing south



Plate 20 Trench 12, post-excitation, facing north