

Appendix B

Vehicle Swept Path Analyses Drawings

- Drawing No. 03183/PL01 – Fire Tender Access and Circulation
- Drawing No. 03183/PL02 – Fire Tender Turning Head
- Drawing No. 03183/PL03 – DB32 Refuse Vehicle Access and Circulation
- Drawing No. 03183/PL04 – DB32 Refuse Vehicle Turning Head
- Drawing No. 03183/PL05 – Large Refuse Vehicle Access and Circulation
- Drawing No. 03183/PL06 – Large Refuse Vehicle Turning Head

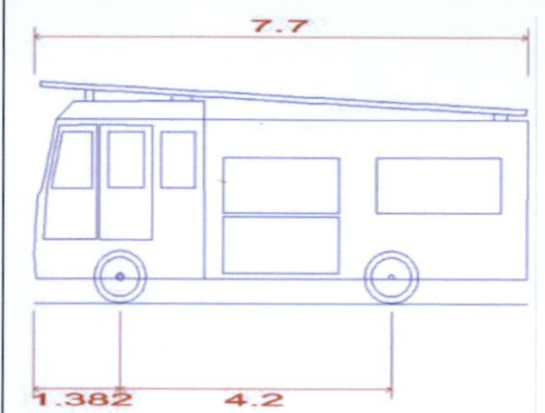

ASSESSMENT VEHICLE

Dennis Sabre Fire Tender (LWB)

Overall length	7.700m
Overall Width	2.430m
Overall Body Height	3.512m
Min Body Ground Clearance	0.397m
Track Width	2.380m
Lock to lock time	5.00s
Kerb to Kerb Turning Radius	7.400m

Wheel Track —

Body Envelope —

TRAFFICWISE
traffic & transportation solutions

Suite No.5, Gowra Plaza
 Bracetown Business Park,
 D15 R59T

Tel: +353 (0)1 825 3015
 Email: info@trafficwise.ie
 Website: www.trafficwise.ie

PROJECT Main Street, Rathcoole, Co. Dublin			
STAGE Request for Further Information dated 16-Oct-2022			
TITLE RFI Item No.4 - Swept Path Assessment			
Description Fire Tender - Access and Circulation			
Surveyed	Drawn by TWL	Checked JMK	Date Jun 2023
SCALE 1:250 (A3)	DRAWING No. 03183/PL01	revision	

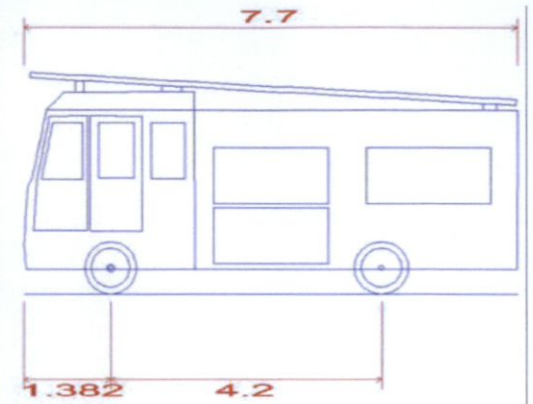
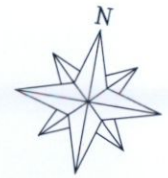

ASSESSMENT VEHICLE

Dennis Sabre Fire Tender (LWB)

Overall length	7.700m
Overall Width	2.430m
Overall Body Height	3.512m
Min Body Ground Clearance	0.397m
Track Width	2.380m
Lock to lock time	5.00s
Kerb to Kerb Turning Radius	7.400m

Wheel Track	1.382m
Body Envelope	4.2m

TRAFFICWISE
traffic & transportation solutions

Suite No.5, Gowna Plaza
Bracetown Business Park,
D15 R59T

Tel: +353 (0)1 825 3015
Email: info@trafficwise.ie
Website: www.trafficwise.ie

PROJECT
Main Street, Rathcoole, Co. Dublin

STAGE
Request for Further Information dated 16-Oct-2022

TITLE
RFI Item No.4 - Swept Path Assessment

Description
Fire Tender - Turning Head

Surveyed	Drawn by TWL	Checked JMK	Date Jun 2023
-----------------	------------------------	-----------------------	-------------------------

SCALE 1:250 (A3)	DRAWING No. 03183/PL02	revision
----------------------------	----------------------------------	-----------------

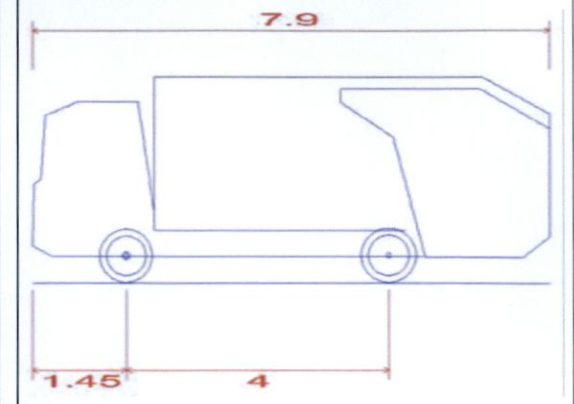

ASSESSMENT VEHICLE

DB32 Refuse Vehicle	
Overall length	7.900m
Overall Width	2.400m
Overall Body Height	3.183m
Min Body Ground Clearance	0.388m
Track Width	2.400m
Lock to lock time	6.00s
Kerb to Kerb Turning Radius	9.625m

Wheel Track —
 Body Envelope —

TRAFFICWISE
 traffic & transportation solutions

Suite No. 5, Gowna Plaza
 Bracetown Business Park,
 D15 R9T

Tel: +353 (0)1 825 3015
 Email: info@trafficwise.ie
 Website: www.trafficwise.ie

PROJECT
 Main Street, Rathcoole, Co. Dublin

STAGE
 Request for Further Information dated 16-Oct-2022

TITLE
 RFI Item No.4 - Swept Path Assessment

Description
 DB32 Refuse Vehicle - Access and Circulation

Surveyed	Drawn by TWL	Checked JMK	Date Jun 2023
-----------------	------------------------	-----------------------	-------------------------

SCALE 1:250 (A3)	DRAWING No. 03183/PL03	revision
----------------------------	----------------------------------	-----------------

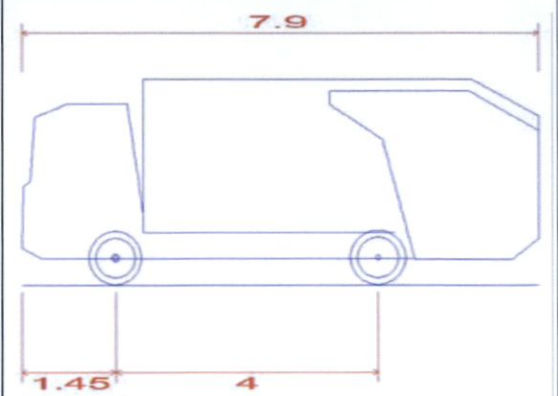

ASSESSMENT VEHICLE

DB32 Refuse Vehicle	
Overall length	7.900m
Overall Width	2.400m
Overall Body Height	3.183m
Min Body Ground Clearance	0.388m
Track Width	2.400m
Lock to lock time	6.00s
Kerb to Kerb Turning Radius	9.625m

Wheel Track —
 Body Envelope —



Suite No 5, Gowra Plaza
 Bracetown Business Park,
 D15 R59T

Tel: +353 (0)1 825 3015
 Email: info@trafficwise.ie
 Website: www.trafficwise.ie

PROJECT
 Main Street, Rathcoole, Co. Dublin

STAGE
 Request for Further Information dated 16-Oct-2022

TITLE
 RFI Item No.4 - Swept Path Assessment

Description
 DB32 Refuse Vehicle - Turning Head

Surveyed	Drawn by TWL	Checked JMK	Date Jun 2023
----------	-----------------	----------------	------------------

SCALE 1:250 (A3)	DRAWING No. 03183/PL04	revision
----------------------------	----------------------------------	----------

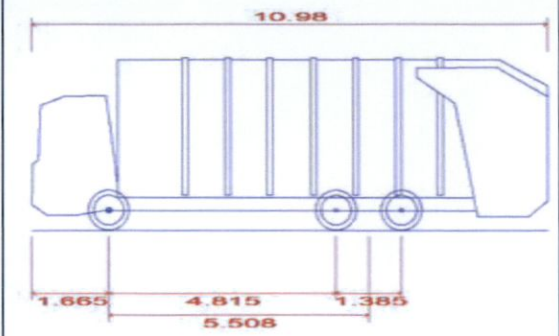
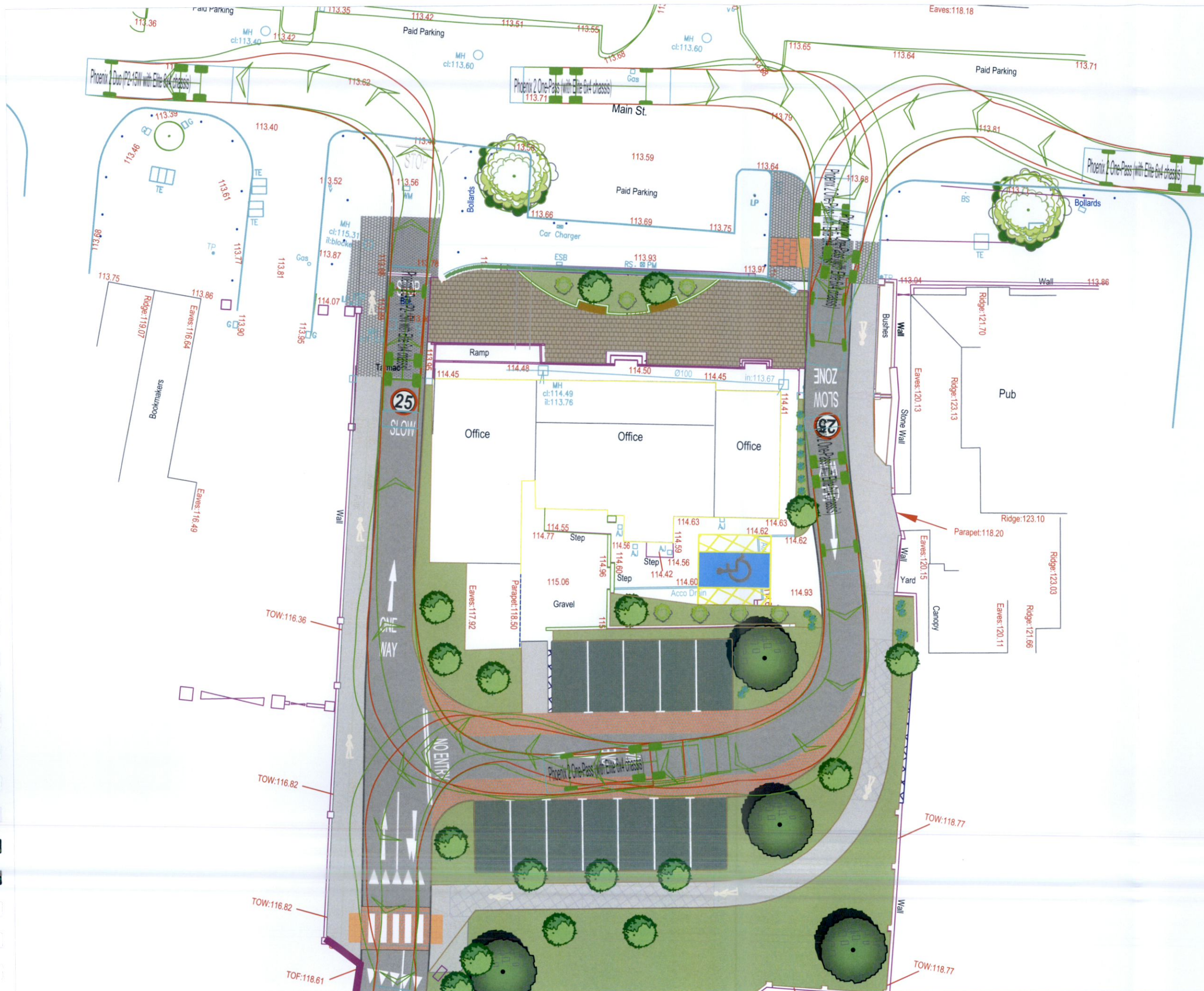

ASSESSMENT VEHICLE

Phoenix 2 One-Pass (with Elite 6x4 chassis)

Overall length 10.980m
 Overall Width 2.500m
 Overall Body Height 3.751m
 Min Body Ground Clearance 0.304m
 Track Width 2.500m
 Lock to lock time 4.00s
 Kerb to Kerb Turning Radius 9.000m

Wheel Track —
 Body Envelope —

TRAFFICWISE
 traffic & transportation solutions

Suite No.5, Gowna Plaza
 Bracetown Business Park,
 D15 R59T

Tel: +353 (0)1 825 3015
 Email: info@trafficwise.ie
 Website: www.trafficwise.ie

PROJECT
 Main Street, Rathcoole, Co. Dublin

STAGE
 Request for Further Information dated 16-Oct-2022

TITLE
 RFI Item No.4 - Swept Path Assessment

Description
 Large Refuse Vehicle - Access and Circulation

Surveyed	Drawn by	Checked	Date
	TWL	JMK	Jun 2023

SCALE	DRAWING No.	revision
1:250 (A3)	03183/PL05	

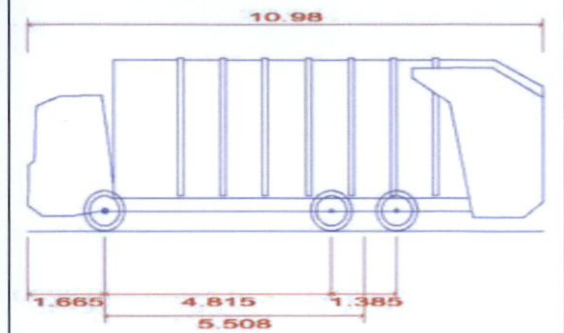

ASSESSMENT VEHICLE

Phoenix 2 One-Pass (with Elite 6x4 chassis)
 Overall length 10.980m
 Overall Width 2.500m
 Overall Body Height 3.751m
 Min Body Ground Clearance 0.304m
 Track Width 2.500m
 Lock to lock time 4.00s
 Kerb to Kerb Turning Radius 9.000m

Wheel Track
 Body Envelope



Suite No. 5, Gowla Plaza
 Bracetown Business Park,
 D15 R59T
 Tel: +353 (0)1 825 3015
 Email: info@trafficwise.ie
 Website: www.trafficwise.ie

PROJECT
 Main Street, Rathcoole, Co. Dublin

STAGE
 Request for Further Information dated 16-Oct-2022

TITLE
 RFI Item No.4 - Swept Path Assessment

Description
 Large Refuse Vehicle - Turning Head

Surveyed	Drawn by TWL	Checked JMK	Date Jun 2023
-----------------	------------------------	-----------------------	-------------------------

SCALE 1:250 (A3)	DRAWING No. 03183/PL06	revision
----------------------------	----------------------------------	-----------------