

POTENTIAL/INDICATIVE ADJACENT DEVELOPMENT (SUBJECT TO SEPARATE PLANNING APPLICATION(S) BY OTHERS).

01 Proposed Site Plan  
PA 001 1:500

NOTES:  
Do not scale from this drawing.  
Any discrepancies found on site to be reported to Darmody Architects immediately.  
Any discrepancies found on drawings to be reported to Darmody Architects immediately.  
Refer to engineers drawings for structural details.  
All dimensions sized to blockwork.

Rev.	Description.	Date.	Initials.
XREF'S			
CAD REF.			

DRAWING KEY	
	Delineates Site Boundary
	Previous building and car parking outline
	Top of Bank Line
	10m Offset from Top of Bank

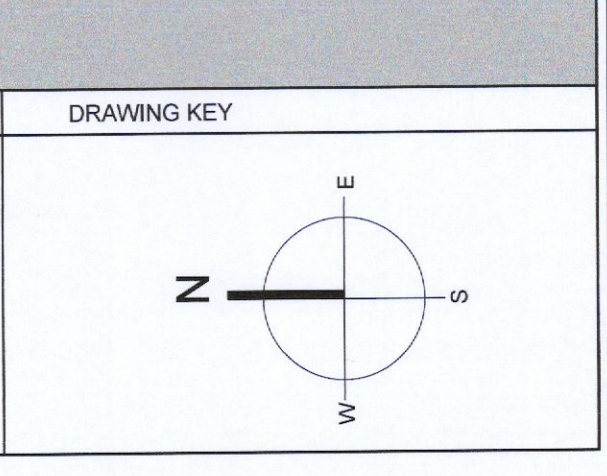
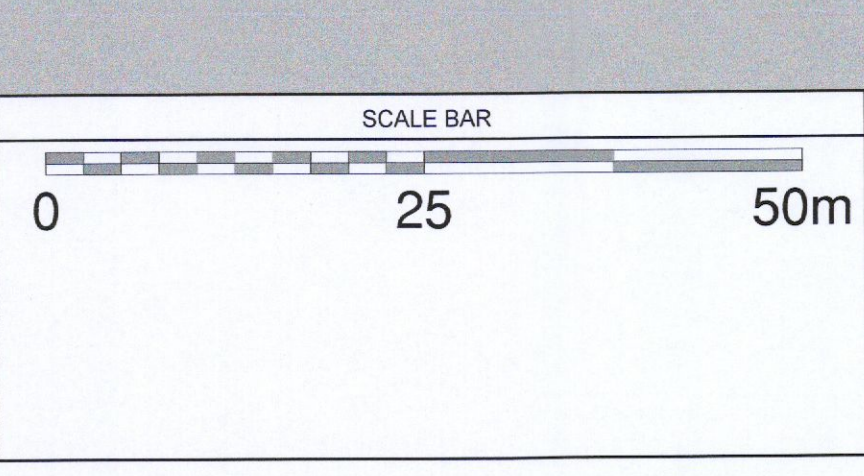

Rev. No.	Scale	Date	Drn. By	Chkd. By	Issue
	1:500 @ A1	30/01/2023	Kevin Barry	Tim Darmody	PLANNING

**creative innovative flexible**

**darmody**  
architecture

91 Townsend Street, Dublin 2  
353 1 672 9907  
info@darmodyarchitecture.com  
darmodyarchitecture.com

Project: Proposed Lidl Store at Newcastle, Co. Dublin	
Title: Proposed Site Plan	
Client: Lidl Ireland GmbH	
Dwg. No. PA-001	Job No. 22013