

NOTES:

- DO NOT SCALE. USE FIGURED DIMENSIONS ONLY.
- THIS DRAWING IS TO BE READ IN CONJUNCTION WITH ALL OTHER RELEVANT ARCHITECTURAL AND ENGINEERING DRAWINGS.

LEGEND:

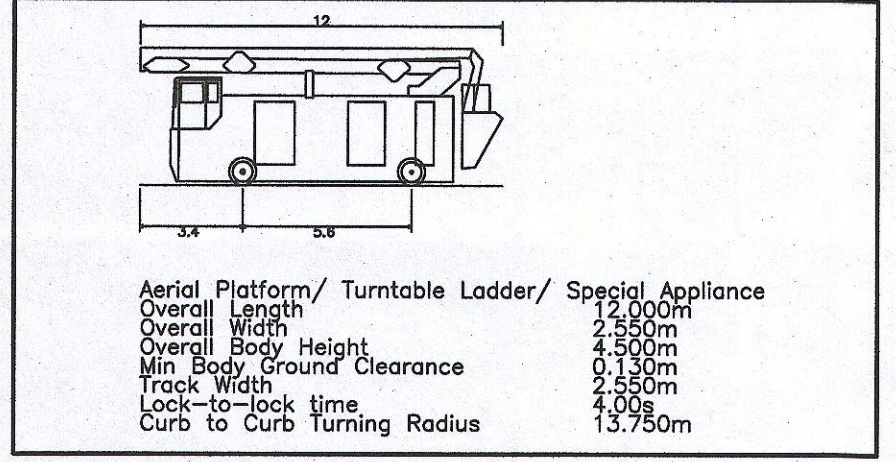

Note: Forward Swept Path Analysis Shown in Red. Reverse in Blue
 Kerb line in Green by Architects.
 Proposed Flush Kerb in Magenta by Waterman/Moylan

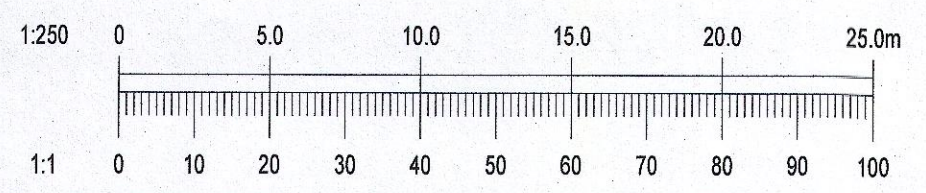
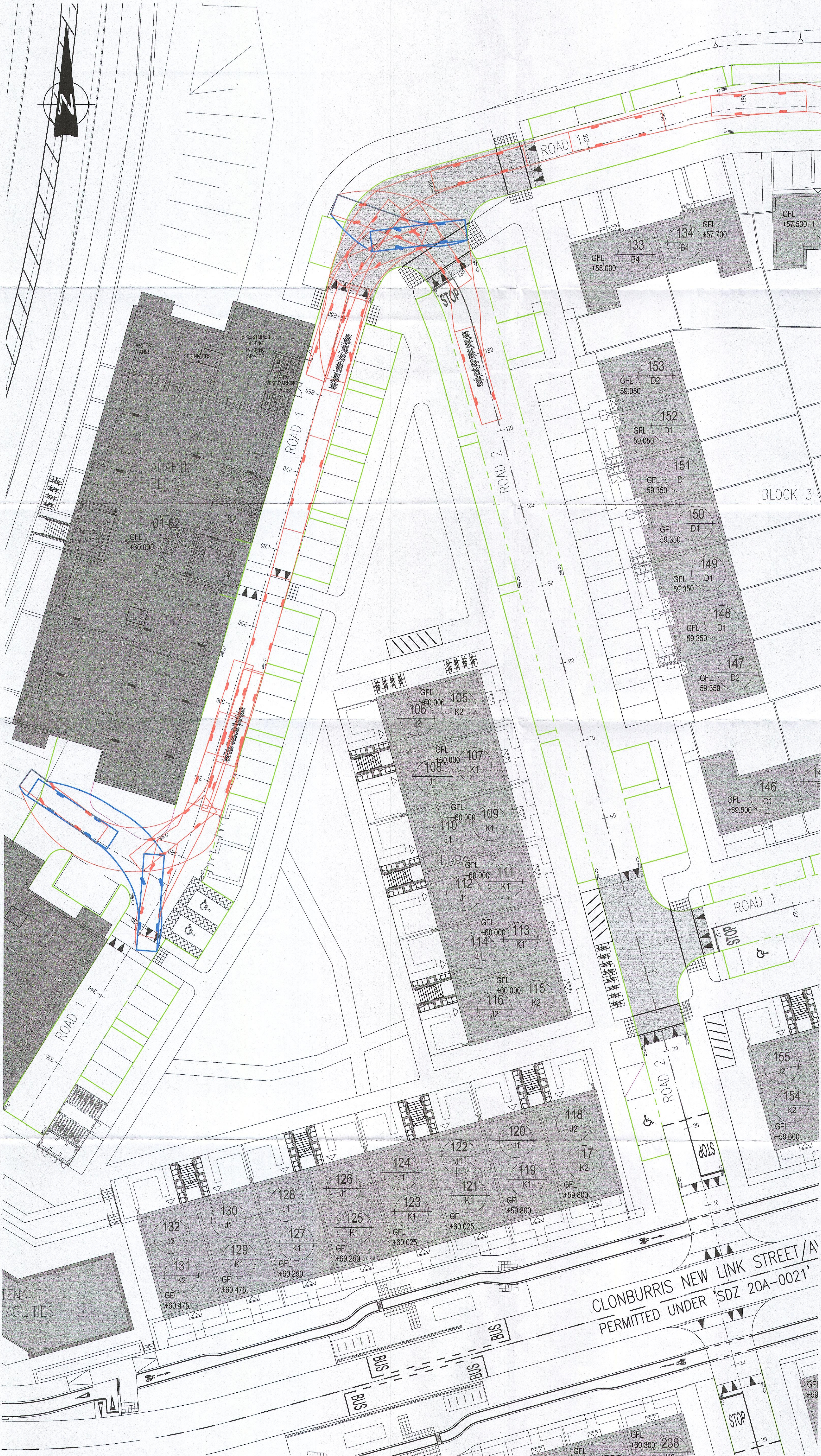

Ordnance Survey Ireland Licence No. EN 0006023
 © Ordnance Survey Ireland/Government of Ireland.

REV.	DATE	AMENDMENT	DRN	APPD

STATUS **FOR INFORMATION**

Waterman Moylan
 Engineering Consultants
 BLOCK 5, EASTPOINT BUSINESS PARK, ALFIE BYRNE ROAD,
 DUBLIN D03 H3P4 IRELAND. Tel: (01) 664 8900
 Email: info@waterman-moylan.ie www.waterman-moylan.ie

CLIENT	QUINTAIN
ARCHITECT	BKD ARCHITECTS
PROJECT	CLONBURRIS
TITLE	PROPOSED VEHICLE TURNING MOVEMENT FOR AN ARIAL PLATFORM

DRAWN	DESIGNED	APPROVED	DATE
PJD	RM	MD	JAN 2023
SCALE	JOB NO.	DRG. NO.	REVISION
1:250 @ A1	21-055	P1112	