

NOTES:
 1. DO NOT SCALE. USE FIGURED DIMENSIONS ONLY.
 2. THIS DRAWING IS TO BE READ IN CONJUNCTION WITH ALL OTHER RELEVANT ARCHITECTURAL AND ENGINEERING DRAWINGS.

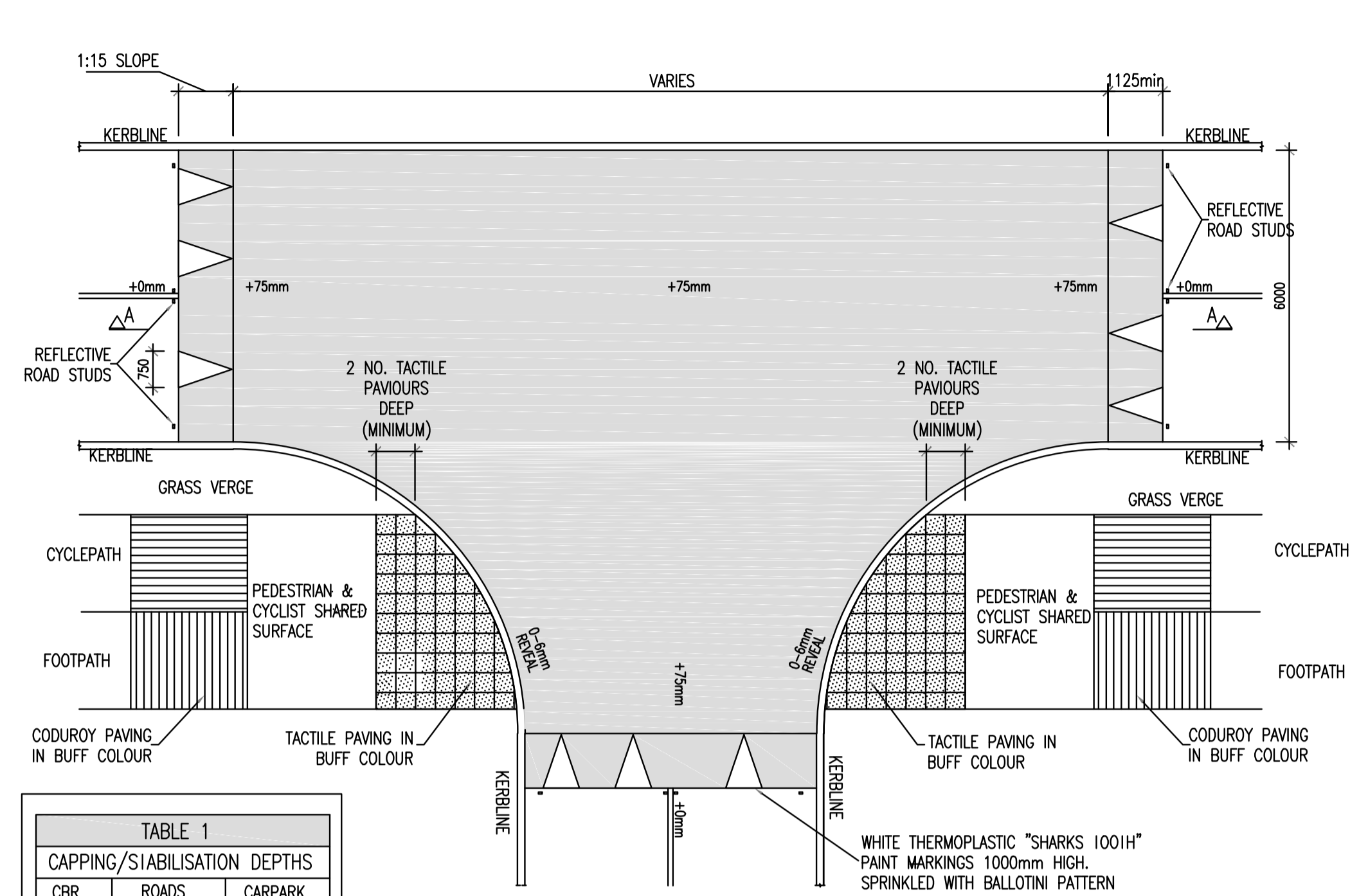
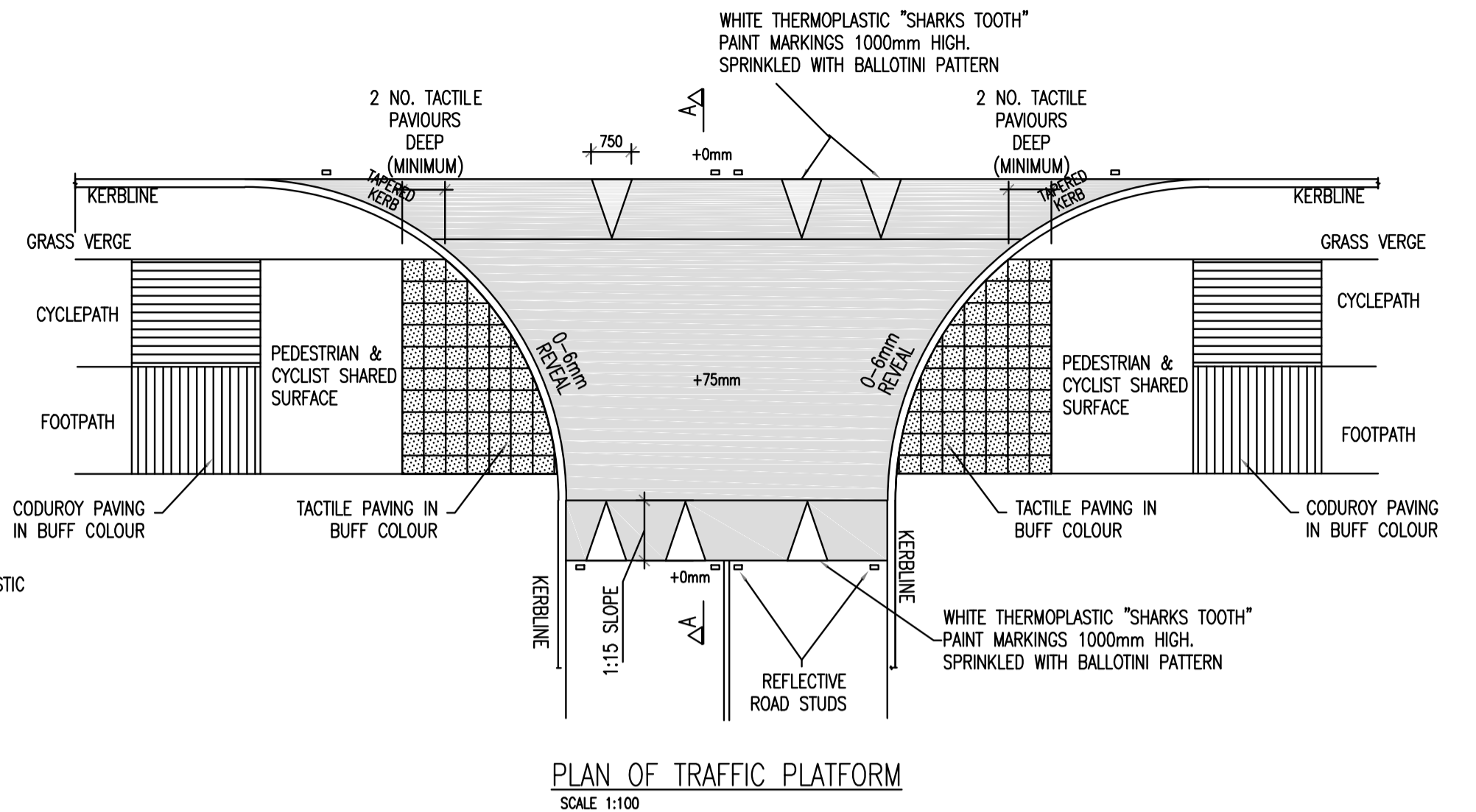
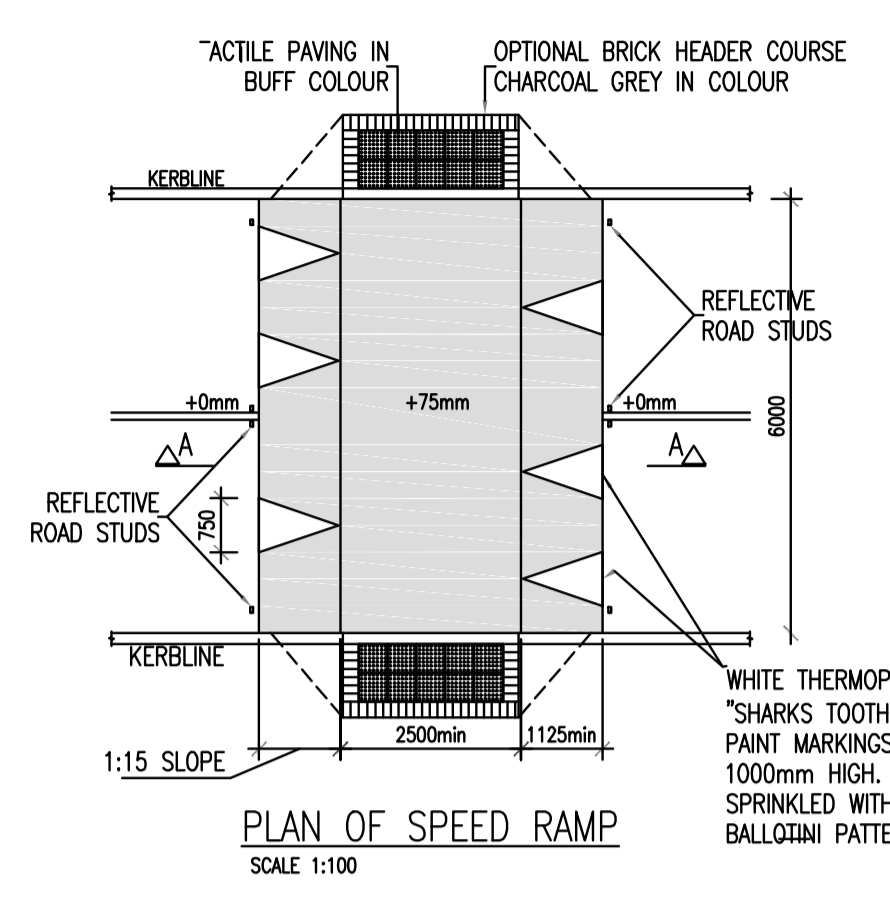

TABLE 1		
CAPPING/STABILISATION DEPTHS		
CBR	ROADS	CARPARK
2%	400	300
3%	300	200
4%	250	150



PLAN OF TRAFFIC PLATFORM (FULL JUNCTION)
SCALE 1:100

PLAN OF SPEED RAMP
SCALE 1:100

PLAN OF TRAFFIC PLATFORM
SCALE 1:100

NOTE:
 1. FOR AREAS WHERE CBR VALUES ARE BELOW 2%, CARRY OUT THE FOLLOWING:
 - THE SOFT AREA IS TO BE EXCAVATED OUT FULLY AND REPLACED WITH A GENERAL FILL MATERIAL (CLASS 1A/1B) TO N.R.A. SPECIFICATION TO THE UNDERSIDE OF AN 'ENKAGRID' LAYER (ENKAGRID TRC 40 OR SIMILAR 40N/m). SEPARATION GEOTEXTILE TO BE PLACED BETWEEN THE SUBGRADE AND CAPPING.
 OR
 - SOIL TO BE STABILISED IN-SITU WITH LIME/CEMENT TO SPECIALIST CONTRACTOR SPECIFICATION TO FORMATION LEVEL, MINIMUM CBR 5%.
 AN ENGINEER SHOULD INSPECT THE SOFT AREA WHEN IT HAS BEEN FULLY EXCAVATED OUT PRIOR TO THE FILL/STABILISED MATERIAL BEING PLACED/WORKED.
 2. FOR AREAS WHERE CBR VALUES ARE BETWEEN 2% AND 5%, CARRY OUT THE FOLLOWING:
 - THE SOIL IS TO BE EXCAVATED OUT FULLY AND REPLACED WITH A CAPPING MATERIAL TYPE 6F1/6F2 TO N.R.A. SPECIFICATION. DEPTHS OF CAPPING MATERIAL AS PER TABLE 1 BELOW. SEPARATION GEOTEXTILE TO BE PLACED BETWEEN THE SUBGRADE AND CAPPING.
 OR
 - SOIL TO BE STABILISED IN-SITU WITH LIME/CEMENT TO SPECIALIST CONTRACTOR SPECIFICATION TO FORMATION LEVEL, MINIMUM CBR 5%. DEPTHS OF MATERIAL TO BE STABILISED AS PER TABLE 1 BELOW.

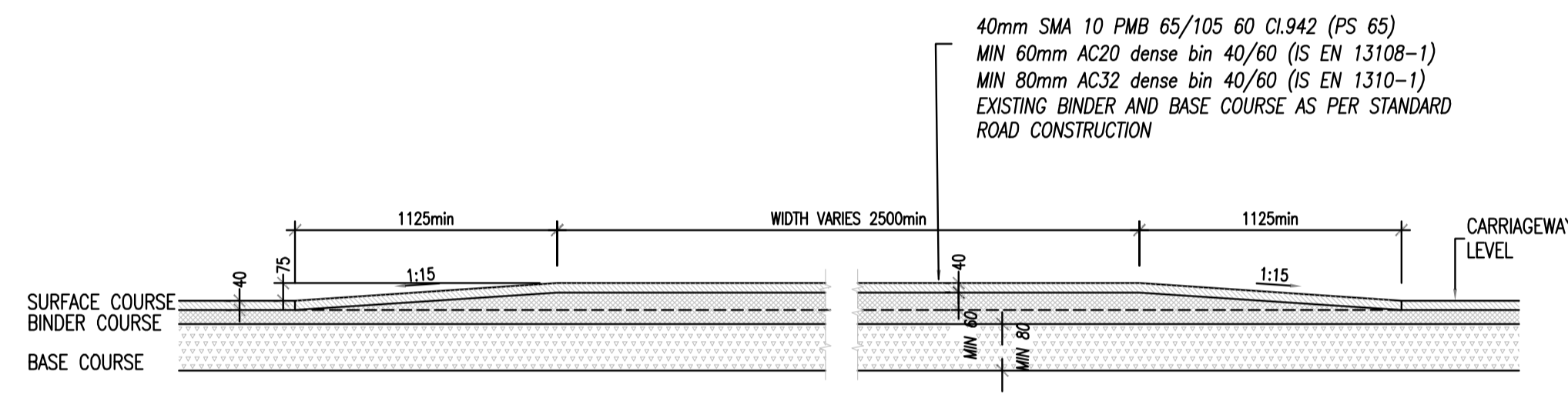

SECTION A-A - THROUGH SPEED RAMP/TRAFFIC PLATFORM
SCALE 1:25

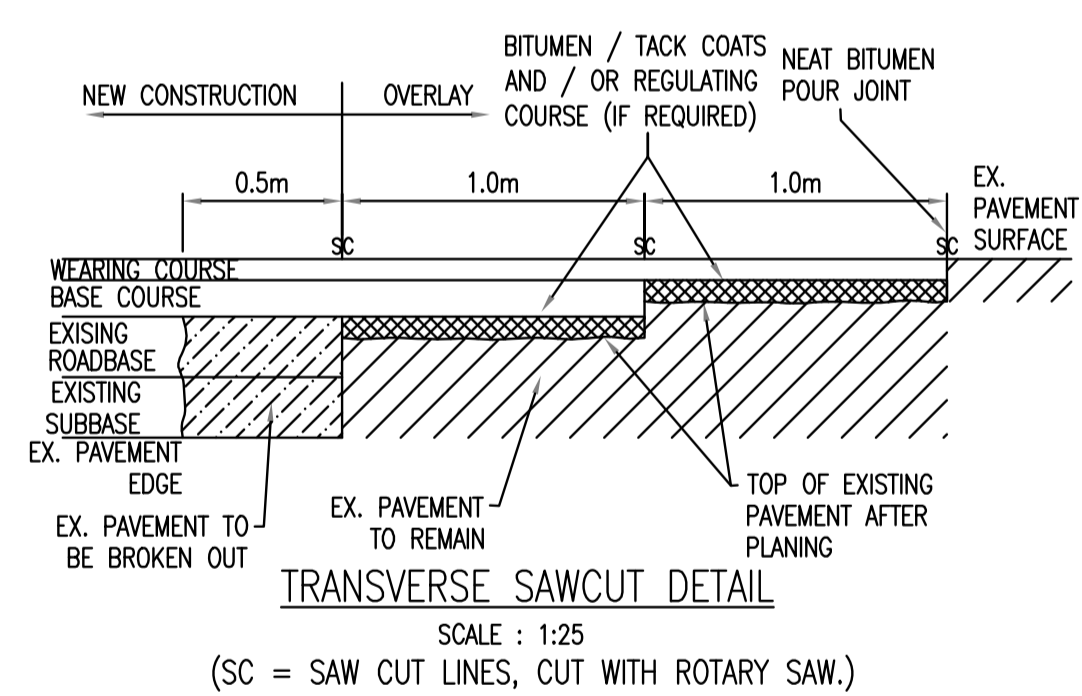
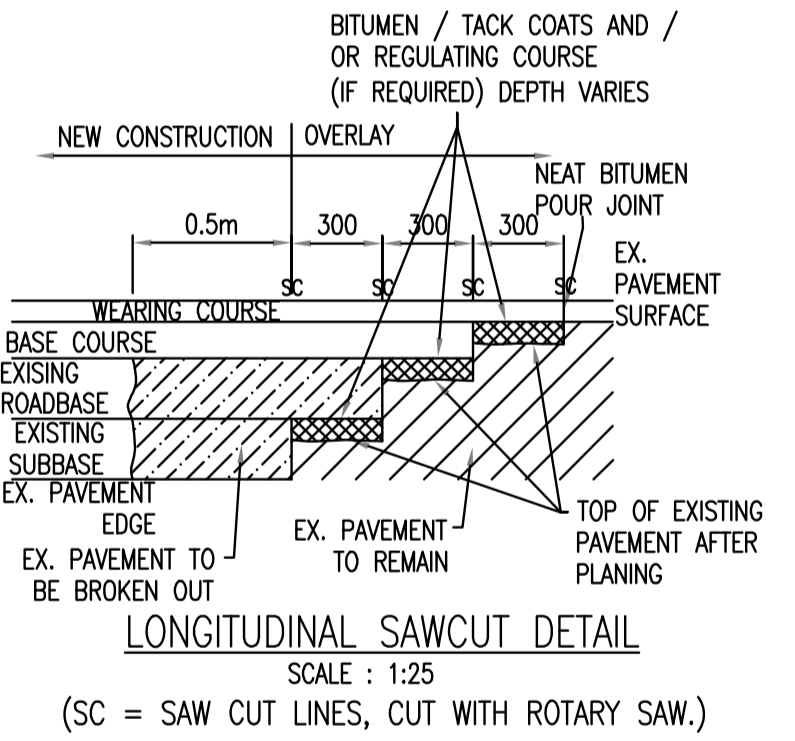
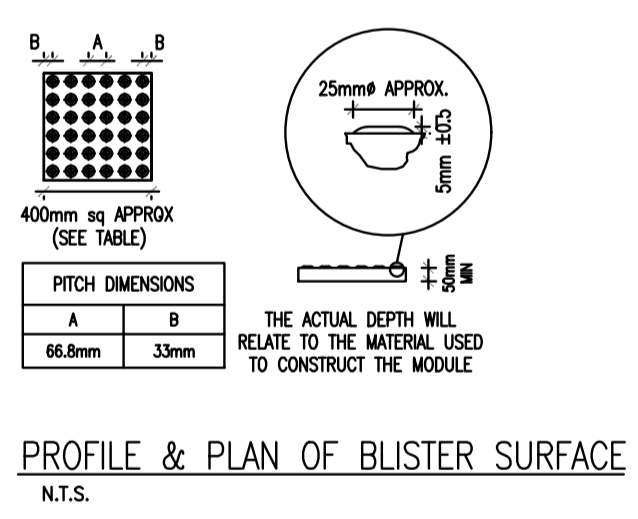
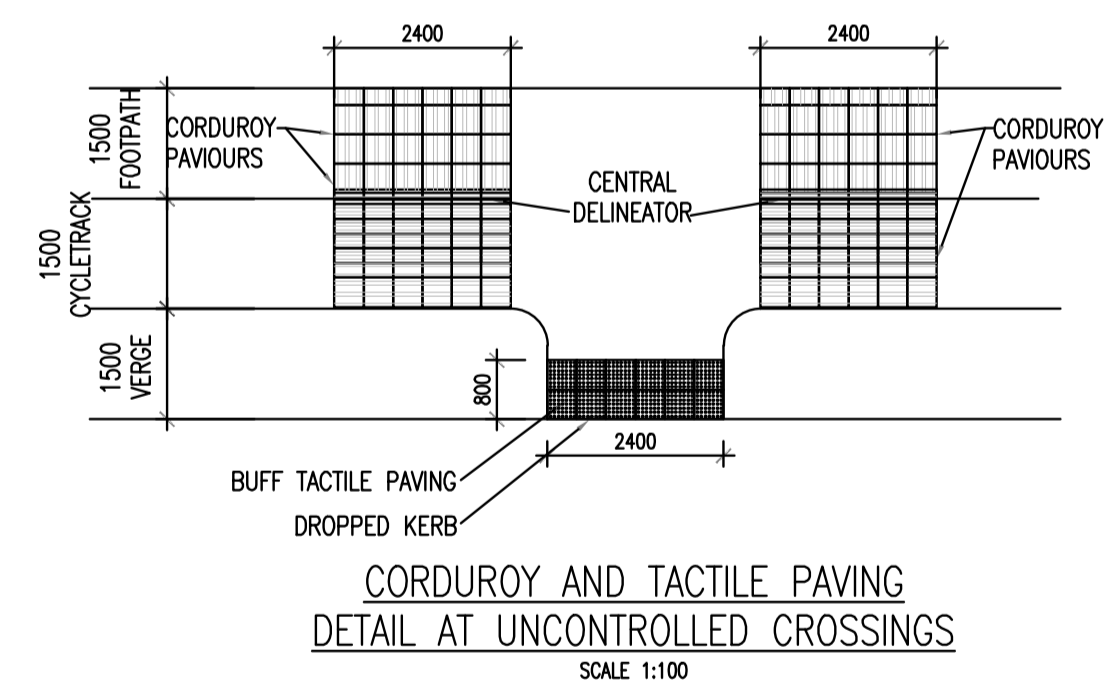

[SUFFICIENT WORKING ROAD MUST BE MADE AVAILABLE TO ENSURE SAWCUT CAN BE CORRECTLY CONSTRUCTED]

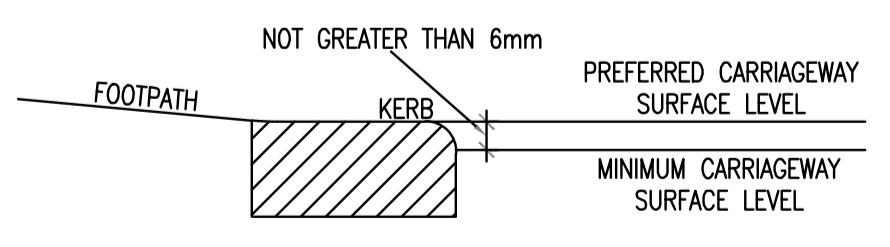
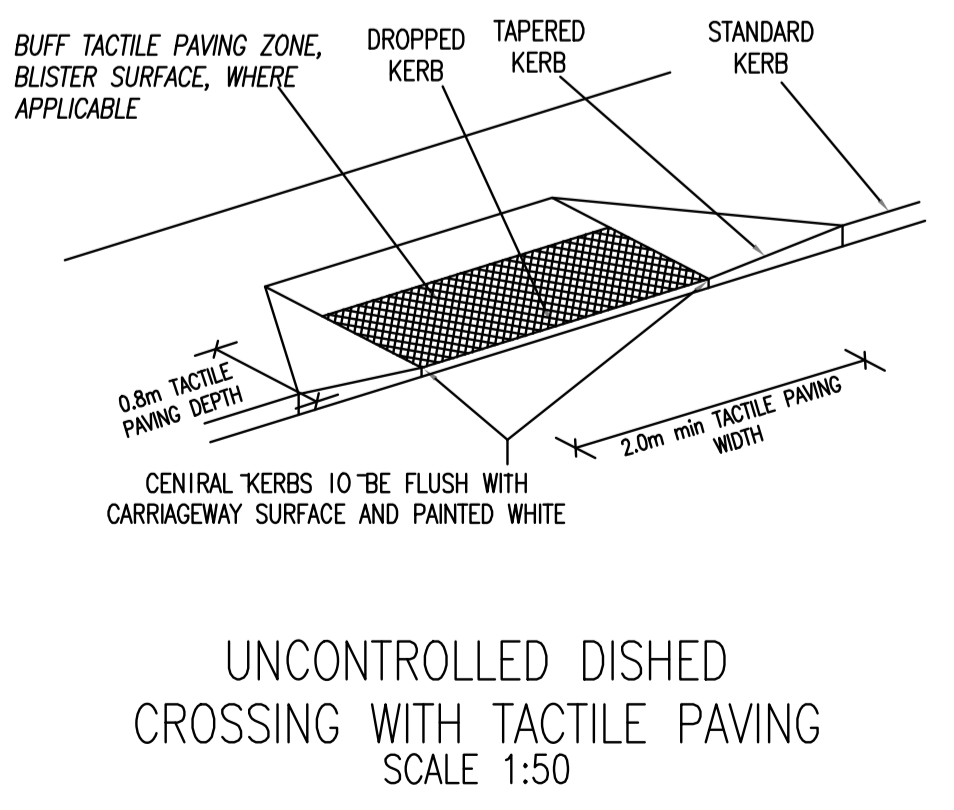
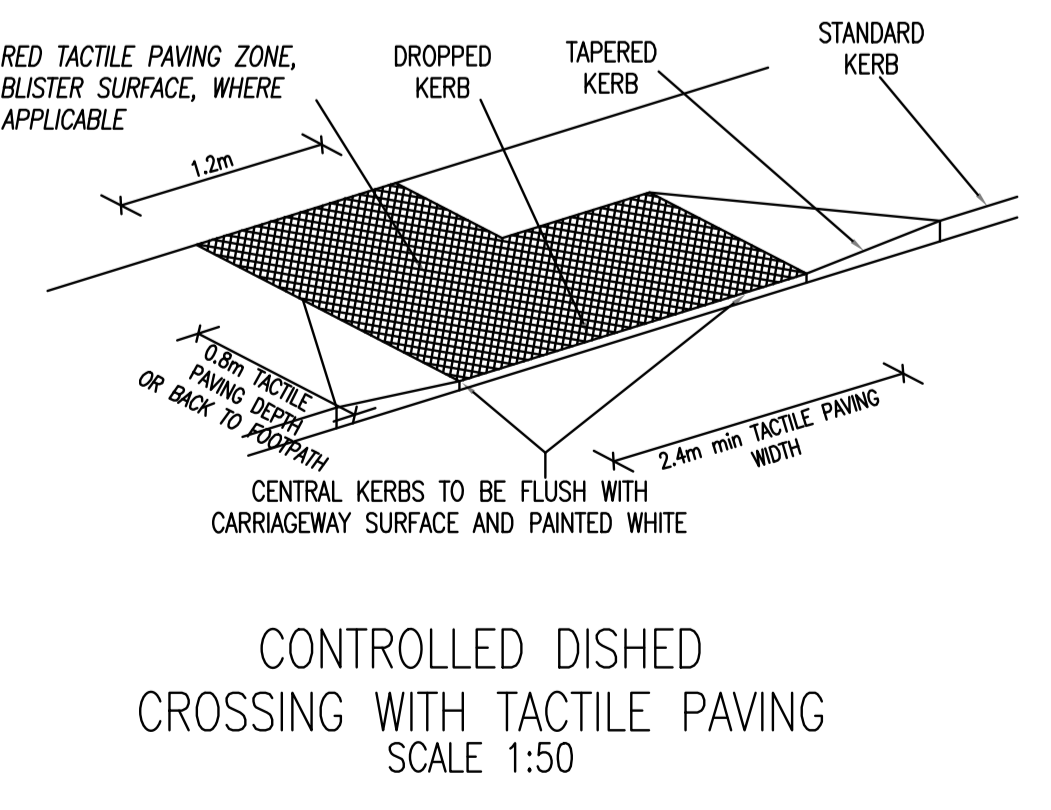

DISHED CROSSING WITH TACTILE PAVING
SCALE nts

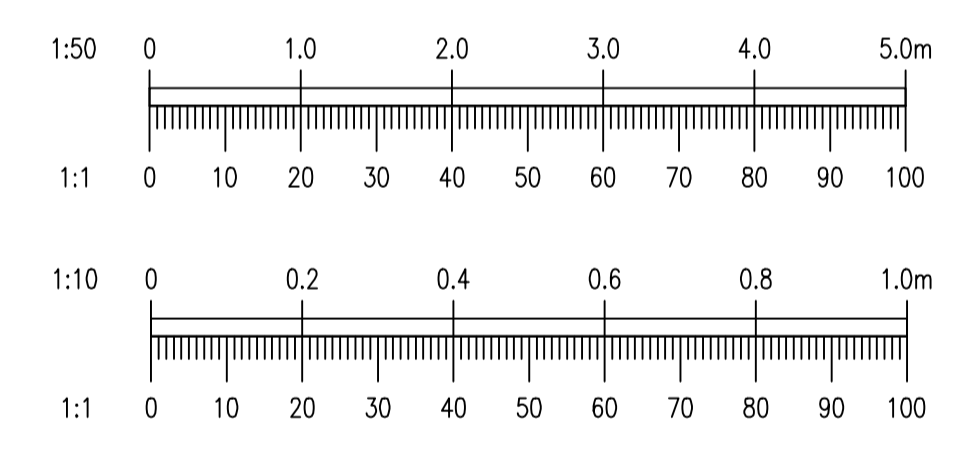
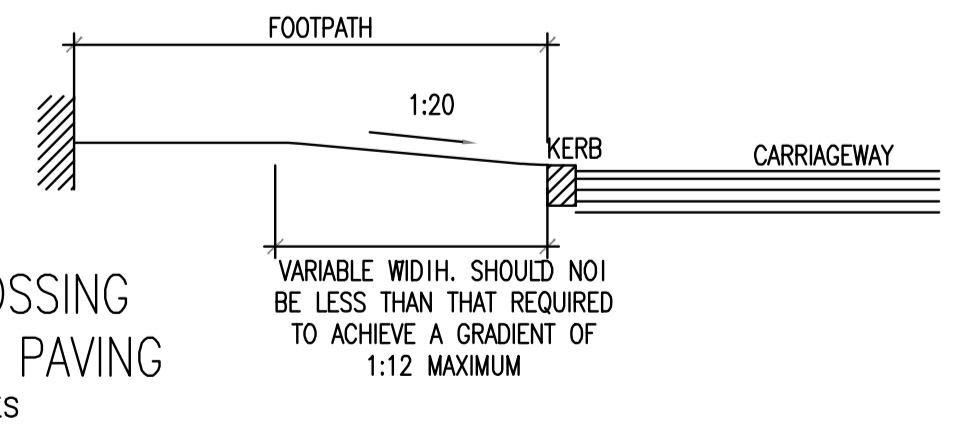

27/01/23	PLANNING COMPLIANCE ISSUE	PW	JB
REV. DATE	AMENDMENT	DRN	APPD

STATUS **FOR PLANNING ONLY NOT FOR CONSTRUCTION**

Waterman Moylan
 Engineering Consultants
 BLOCK 9, EASTPOINT BUSINESS PARK, ALFIE BYRNE ROAD,
 DUBLIN D03 H3F4 IRELAND. Tel: (01) 664 8900
 Email: info@waterman-moylan.ie www.waterman-moylan.ie

CLIENT **QUINTAIN DEVELOPMENTS IRELAND Ltd.**
 ARCHITECT **MOLA ARCHITECTS**
 PROJECT **TANDY'S LANE VILLAGE - PHASE 2**

TITLE **TYPICAL ROAD CONSTRUCTION DETAILS SHEET 2 OF 2**

DRAWN PW	DESIGNED JB	APPROVED IW	DATE JAN. 2023
SCALE AS SHOWN@A1	JOB NO. 21-058	DRG. NO. P191	REVISION -

© 2022. This drawing is copyright. No part of this document may be re-produced or transmitted in any form or stored in any retrieval system of any kind without the written permission of the consulting engineer or copyright holder except as agreed for use on the project for which the document was originally issued.