

ADDITIONAL INFORMATION.

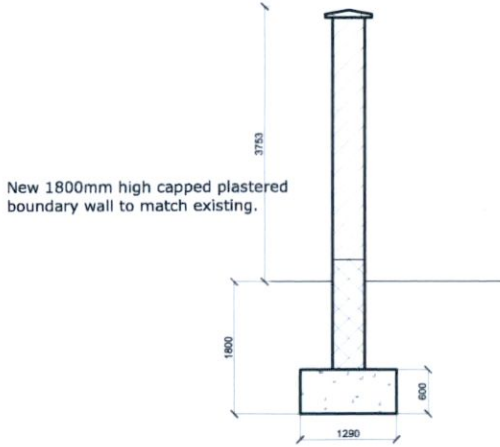

PROPOSED FRONT ELEVATION

No146 No145



CROSS SECTION THRO. BOUNDARY WALL.
Scale 1:50



PROPOSED GABLE ELEVATION

St. MAELRUAN'S PARK

New car park: remove ex. conc boundary plinth and lay in new Roadstone Aquaflo permeable paving on 2-8mm clean stone Inbitex Geotextile on 2 layer sub-base: top layer 5-20mm aggregate, bottom layer 15-20mm aggregate on Inbitex Geotextile on BC Intergrid on subgrade.

DESMOND J. HALPIN & ASSOCIATES
Planning & Building Design Consultants

15 Carriglea Drive, Firhouse, Dublin 24 Phone: 01-4523710 Email: deehalpin15@gmail.com

PROPOSED DEVELOPMENT AT 146 BL MAELRUANS PARK, TALLAGHT, DUBLIN 24,	Scale 1:100 @ A3. 1:50 @ A3.	Drawn DJH
BOUNDARY WALL ELEVATIONS.	Drawing No 16-10 -22	Rev
MARY DALTON.	Date Jan. 2023.	Chk JK