

PROPOSED SIDE ELEVATION

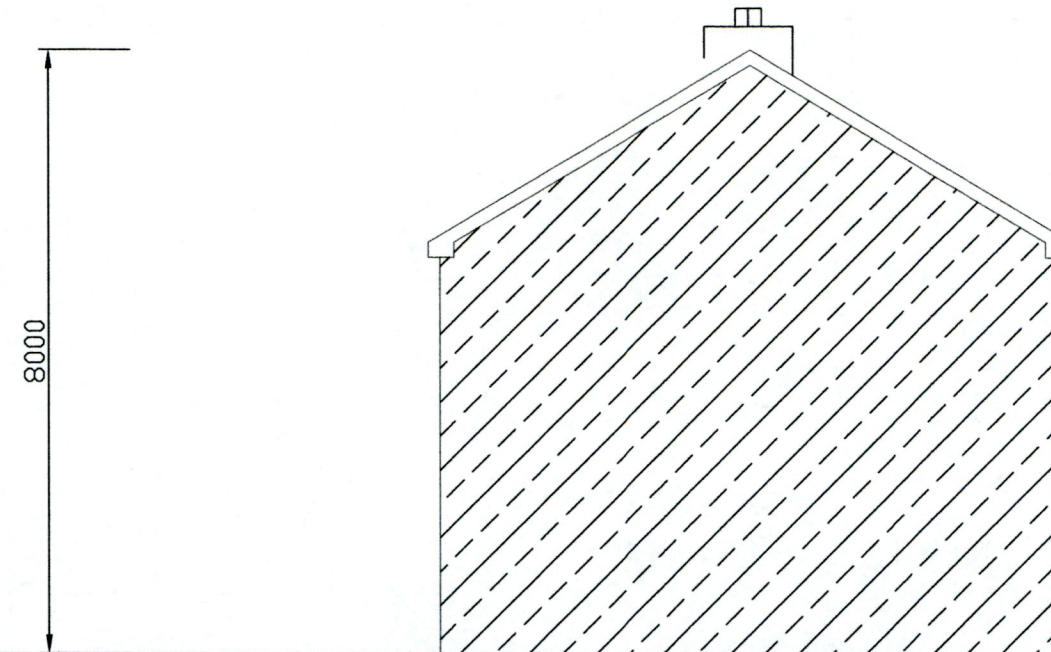

EXISTING SIDE ELEVATION

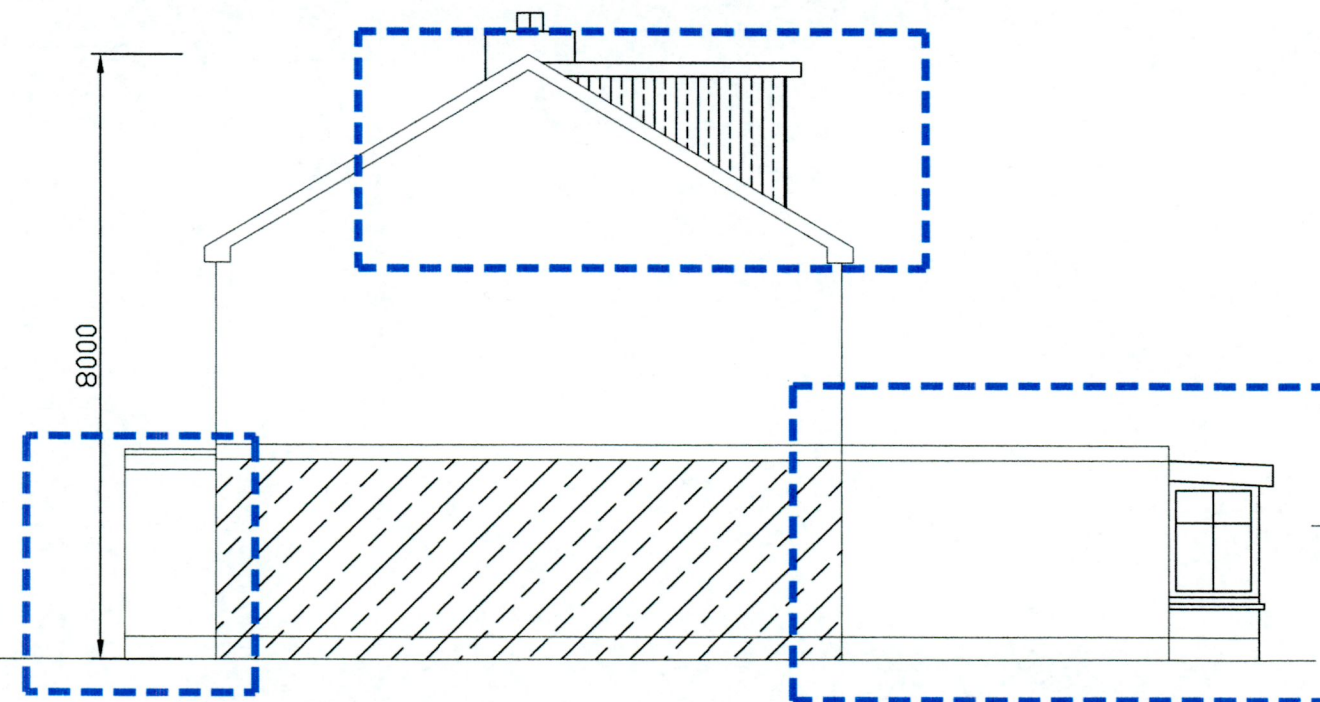

PROPOSED SIDE ELEVATION

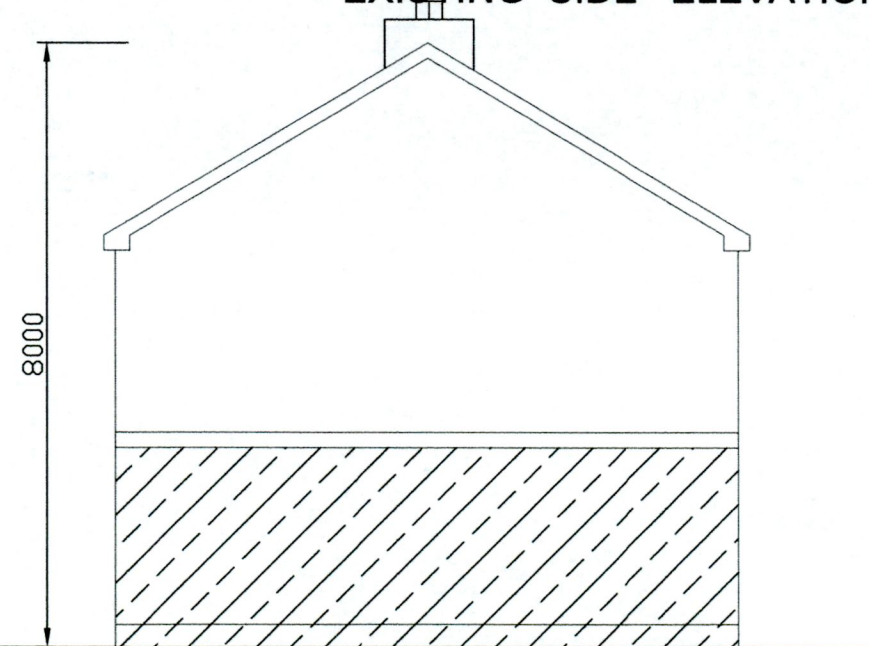

EXISTING SIDE ELEVATION



I2B ARCHITECTS

H2B 20 MOY VIEW KILDALKEY CO MEATH		tel: 01) 4030922 / 087) 1326871	
project:	PROPOSED ATTIC	project number:	2014-14
	JENNIFER AND KEITH O NEILL	date:	12/04/2022
	39 LAUREL PARK	drawing number:	2014-23A
	CLONDALKIN DUBLIN 22	scale:	1:100
subject:	ELEVATIONS	designed by:	JACKIE QUINN
		checked by:	BRENDAN JOHNSTON
		size:	A3