

⊕ Ground Floor Plan
 Total Floor area 51m sq.
 Works Retention - Ground floor front extension
 Ground floor front extension area = 5msq
 Ground floor rear extension area = 9m sq

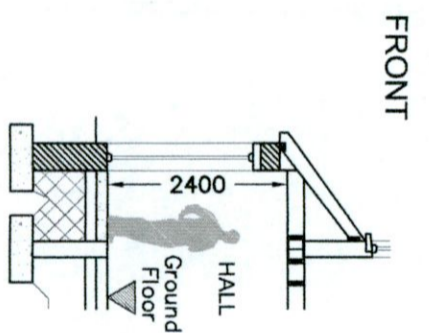

⊕ Section A-A

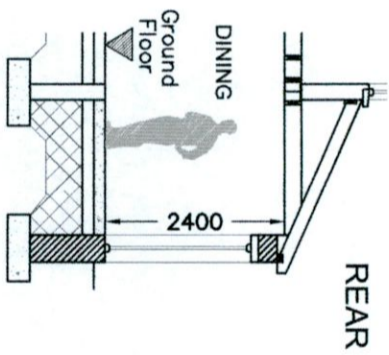

⊕ Section B-B

P	ISSUED FOR PLANNING	TW	NOV 2022
REV:	REVISION TITLE:	DRN:	CHD:
		DATE:	

Architectural Planning

4 CARRIGMORE CLOSE, AYLESBURY,
 Dublin 24 - Ph: 01 4148358

Issued for Planning

CLIENT: VLADIMIR STEPHANENKO

JOB TITLE: PROPOSED WORKS FOR RETENTION
 AT 13 FORTUNESTOWN CLOSE, TALLAGHT,
 DUBLIN 24

TITLE: EXISTING GROUND FLOOR PLAN
 & SECTIONS

SCALE: 1:100 INITIALS: TW DATE: NOV 2022

JOB No: S284 DRAWING No: 001

REV: P

THIS DRAWING IS ISSUED FOR PLANNING PERMISSION ONLY, AND IS NOT A CONSTRUCTION DRAWING

NOTES:

This drawing is to be read in conjunction with all relevant Engineers drawings.
 Do not scale use figured dimensions ONLY.
 All dimensions in millimeters unless otherwise stated.
 All dimensions to be checked on site.
 All building works to comply with current building regulations & in accordance with Homebond Standards.