

REVISION SCHEDULE				
REV. NO.	REV. DESCRIPTION	REV. DATE	DRAWN	CHECKED
PL01	ISSUED FOR PLANNING	16/11/2022	PAF	JO'B

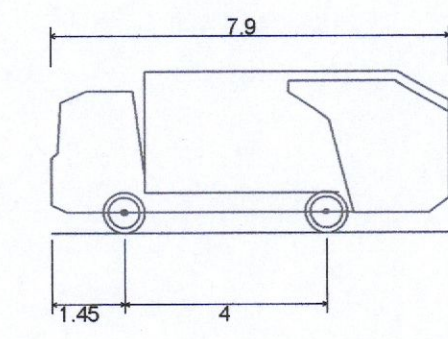

DB32 Refuse Vehicle  
 Overall Length 7.900m  
 Overall Width 2.400m  
 Overall Body Height 3.183m  
 Min Body Ground Clearance 0.388m  
 Max Track Width 2.400m  
 Lock-to-lock time 6.00s  
 Curb to Curb Turning Radius 9.625m

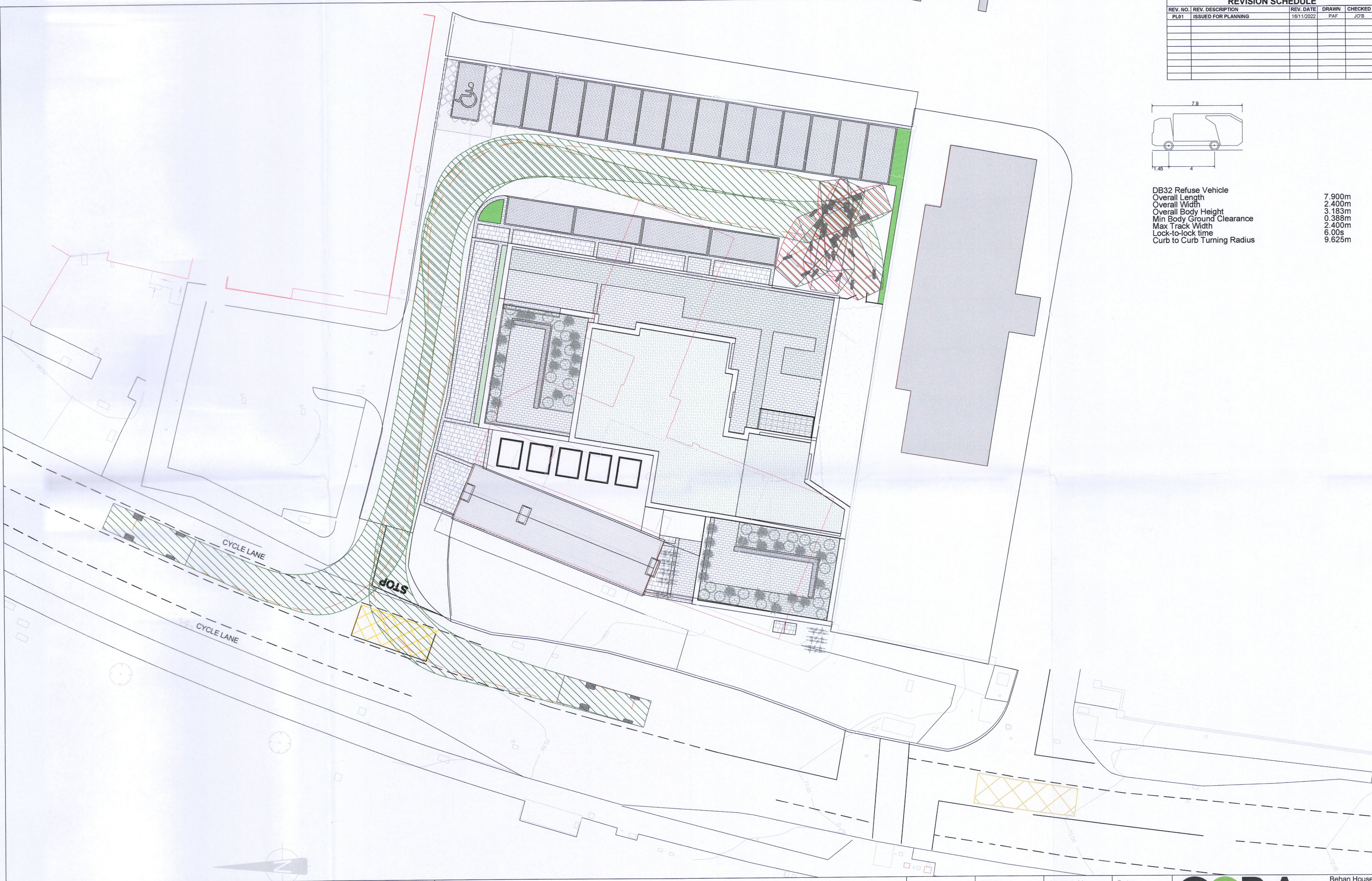

Drawing Stage:  
**PLANNING**

Project Details:	
Site Address:	CUCKOO'S NEST PUB, GREENHILLS ROAD, KILNAMANAGH
Client:	-
Architect:	DAVEY SMITH ARCHITECTS
M&E Designer:	-
Contractor:	-

Notes

Drawn by: PAF	Checked by: JO'B	Approved by: JMCM	Date: 19/10/2022
Project Name: <b>CUCKOO'S NEST</b>		Scale: 1:150 @ A1	Project Number: 21816
Drawing Title: PROPOSED REFUSE TRUCK VEHICLE TRACKING EXISTING ROAD LAYOUT		Project: 21816	Originator: CORA Zone: - Level: - Type: DR Discipline: C Drawing No: 201A Stage: PL Revision: 01

**CORA**  
CONSULTING ENGINEERS

Behan House,  
10 Lower Mount Street,  
Dublin 2, D02 HT71  
Tel: +353 1 661 1100  
e-mail: info@cora.ie  
Web: www.cora.ie