

PIPE Ø (mm)	MANHOLE TYPE			
	A	C	D	E
UP TO 225	700 x 900	900		
300	700 x 900	1050	1050	1050
375	700 x 900	1200	1200	1200
450	700 x 900	1350	1350	1350
525	700 x 900	1500	1500	1500
600	1200	1200	1200	1200
675	1350	1350	1350	1350
750	1500	1500	1500	1500
800	1500	1500	1500	1500

**NOTES**

- ALL DIMENSIONS ARE IN MILLIMETRES (mm) UNLESS NOTED OTHERWISE.
- ROODING EYE CHAMBER SHALL BE COVERED WITH APPROVED HEAVY DUTY METAL COVERS TO IS 261 AND BS 5834. COVER AND FRAME SHALL BE SUITABLE FOR ROAD AND TRAFFIC CONDITIONS AND IS SUBJECT TO THE APPROVAL OF IRISH WATER.
- ALL CHAMBERS TO BE CHECKED FOR UPLIFT BY THE DEVELOPER BASED ON GROUND CONDITIONS WITHIN THE SITE. SHOULD ANTI FLOTATION MEASURES BE REQUIRED THEY SHALL BE SUBJECT TO APPROVAL FROM IRISH WATER.
- ALL CONCRETE TO BE IN ACCORDANCE WITH IS EN 206.
- MANHOLE DETAILS TO BE IN ACCORDANCE WITH IRISH WATER STANDARDS.

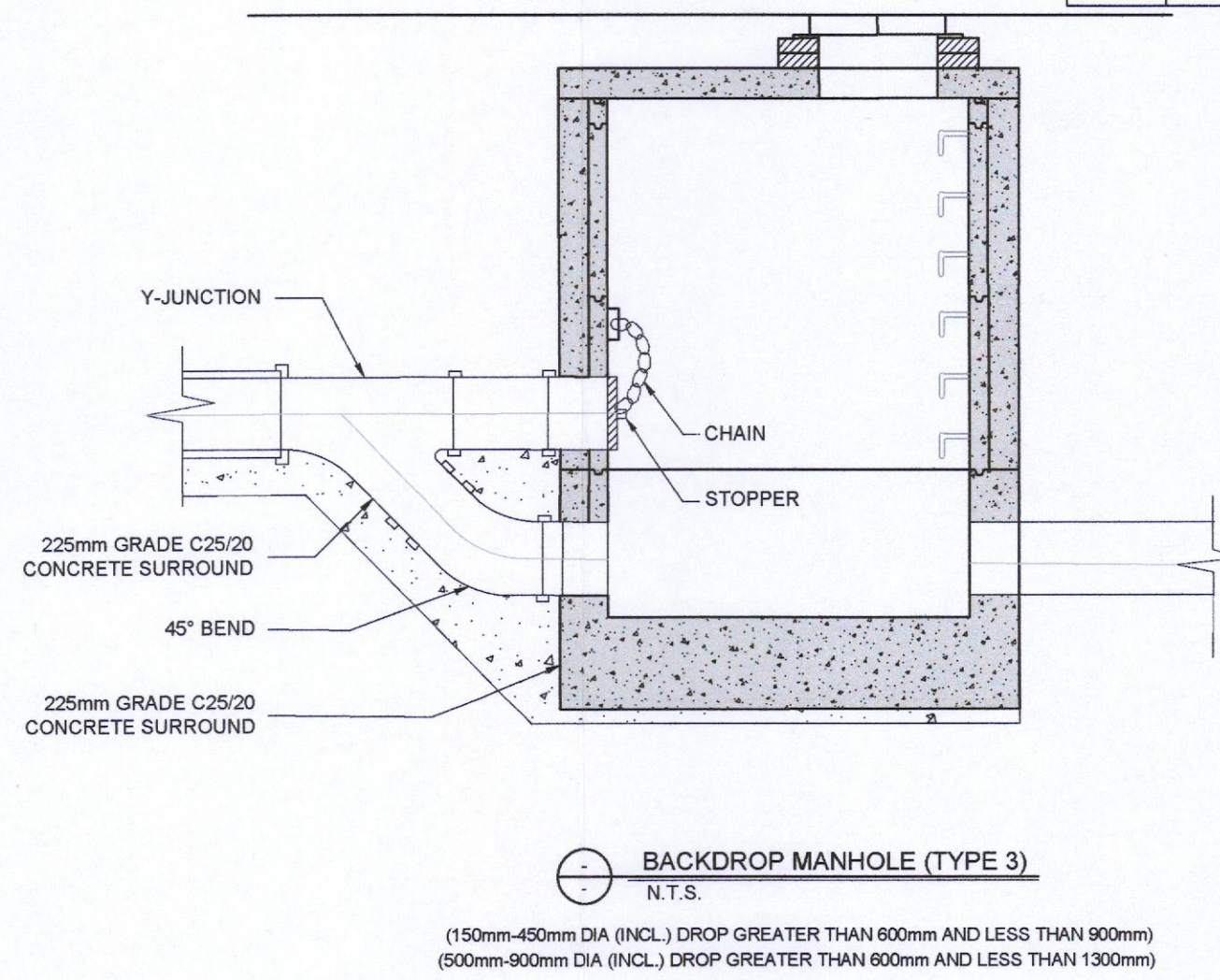
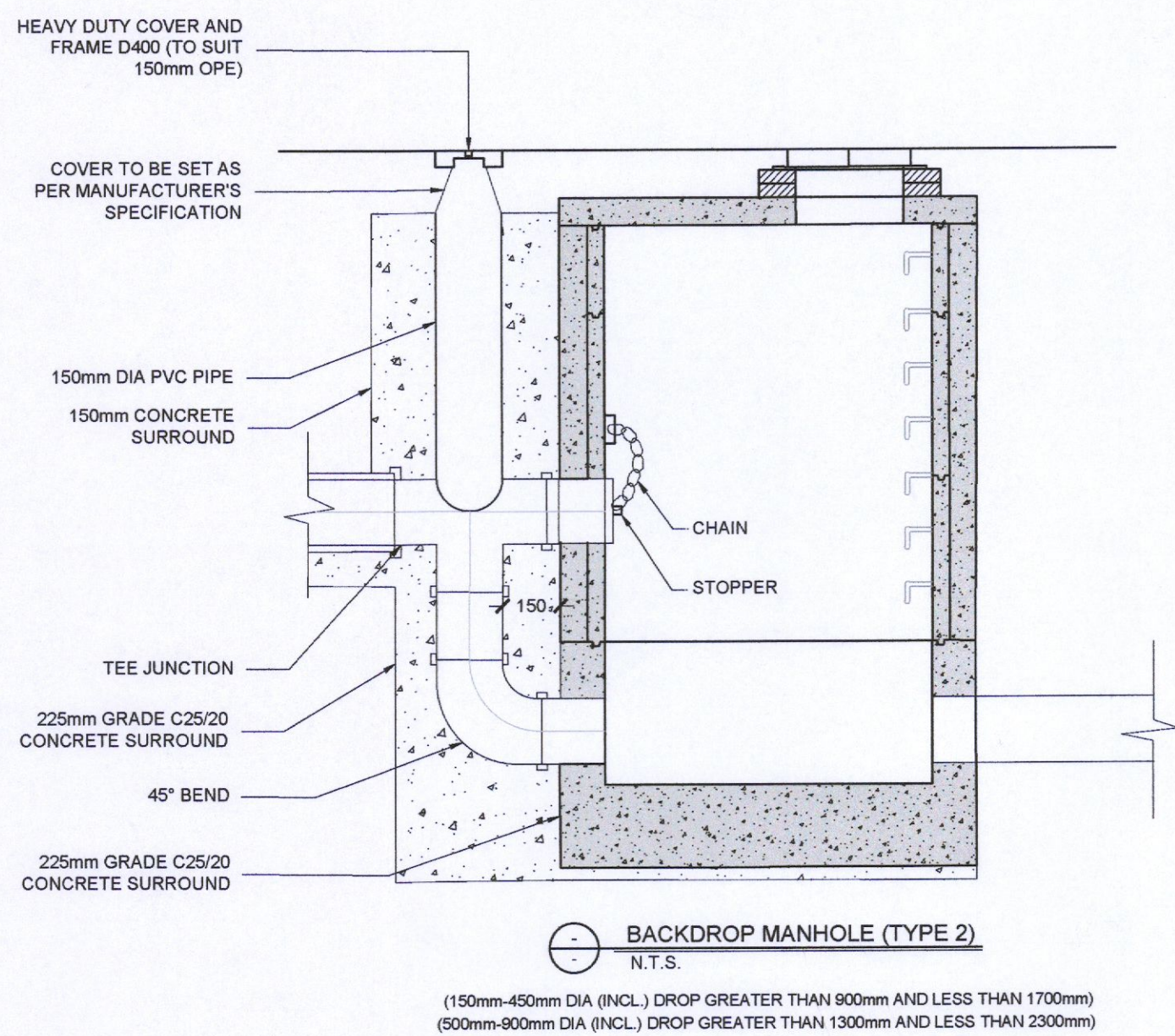
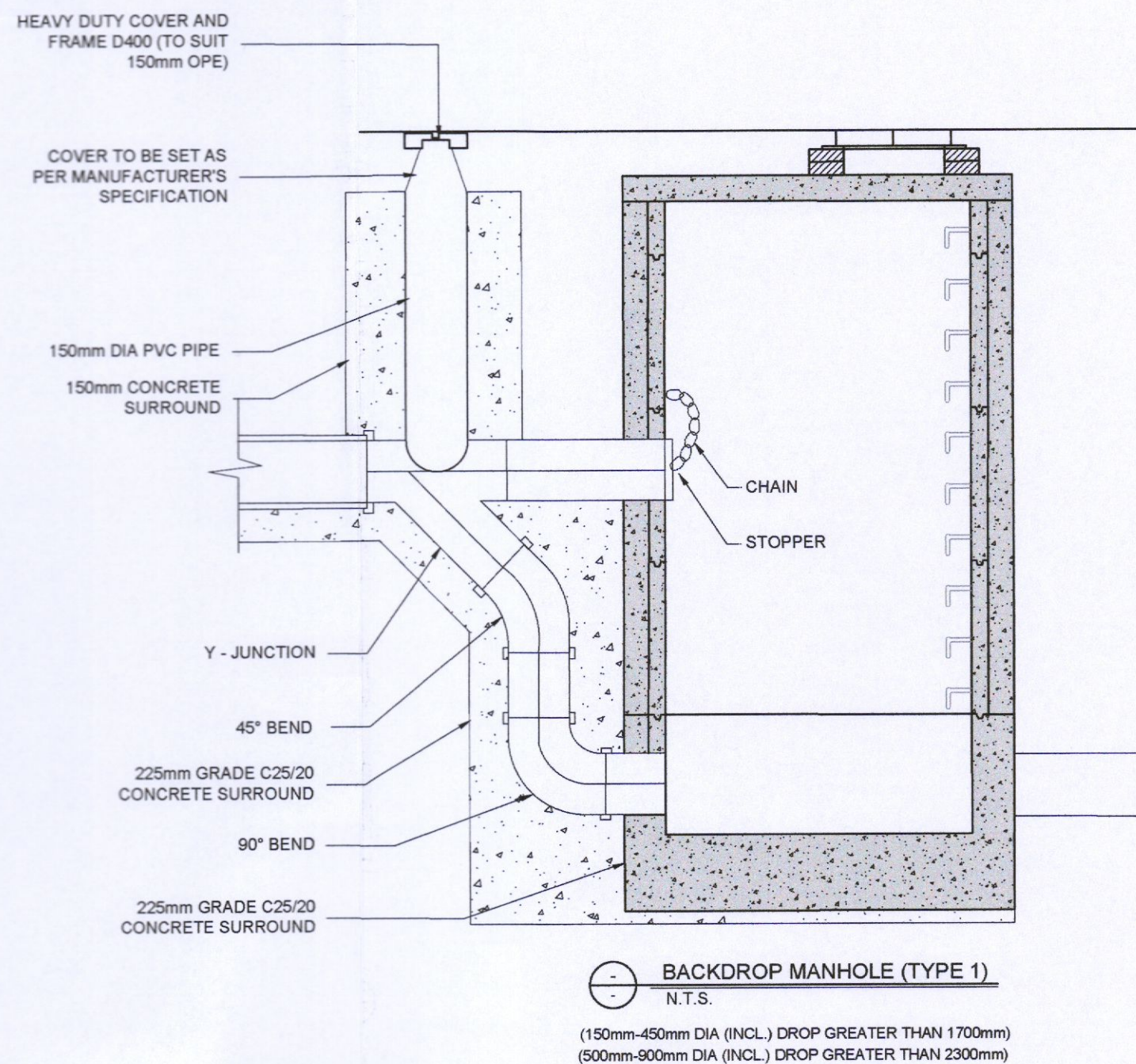

REVISION SCHEDULE				
REV. NO.	REV. DESCRIPTION	REV. DATE	DRAWN	CHECKED

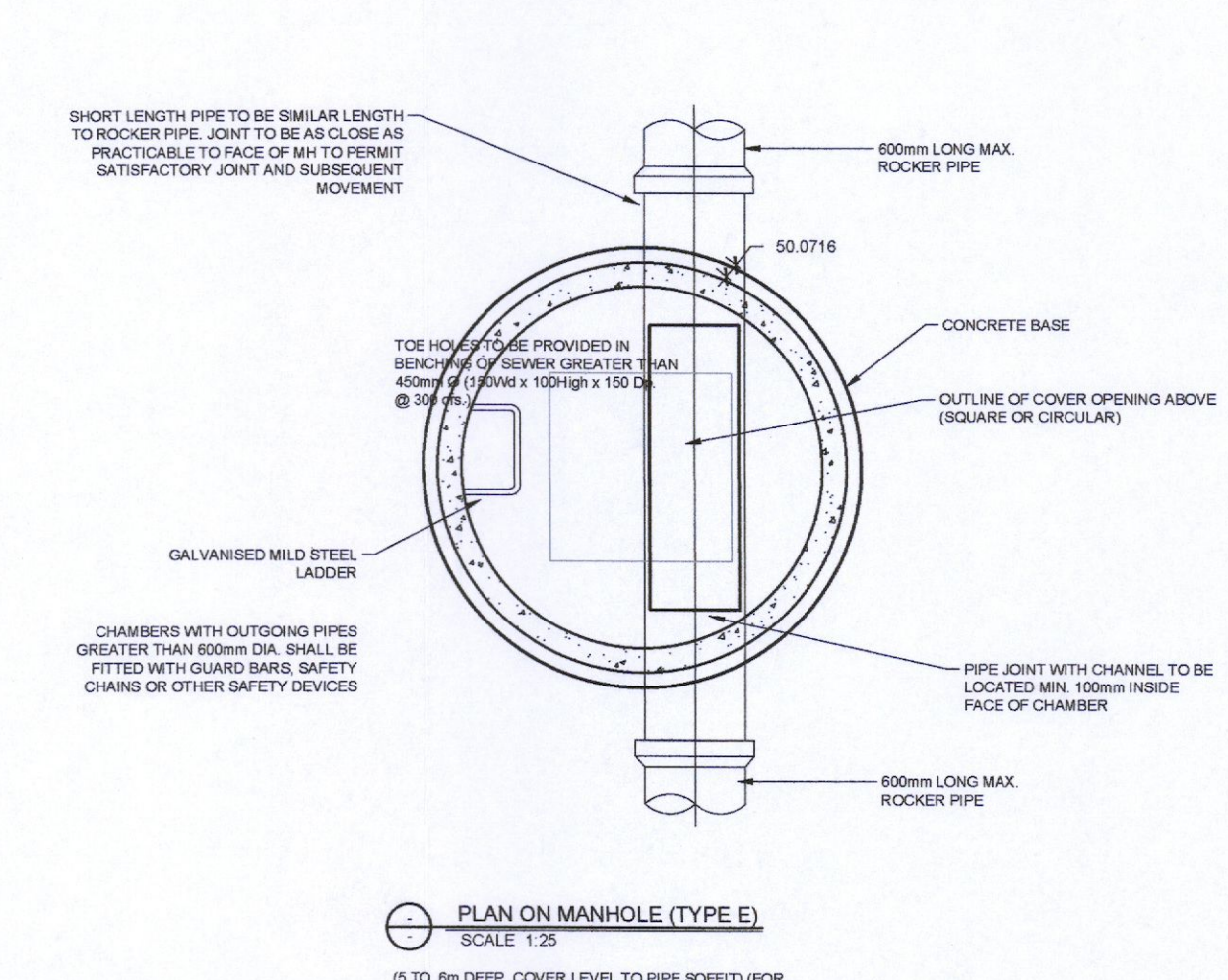
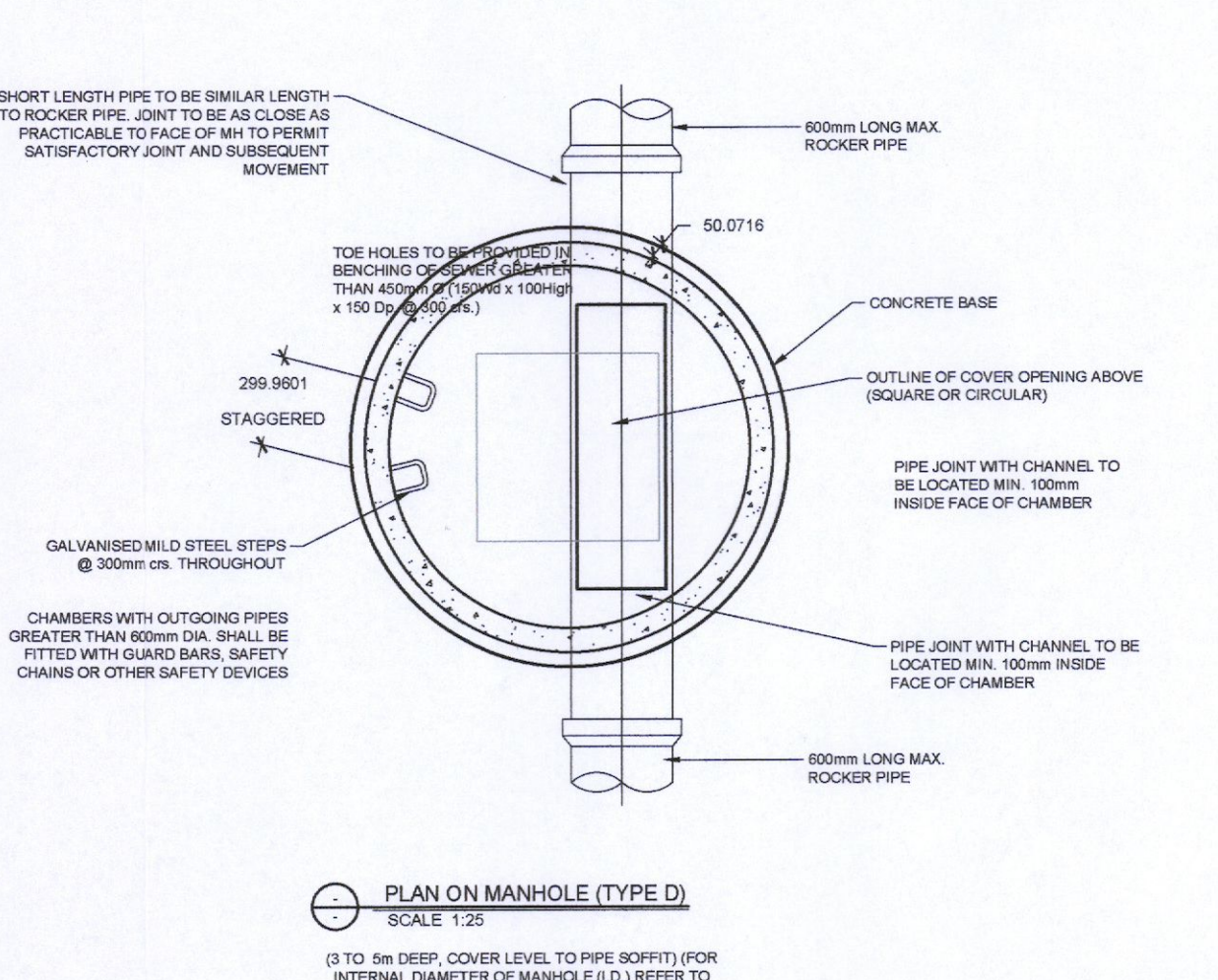
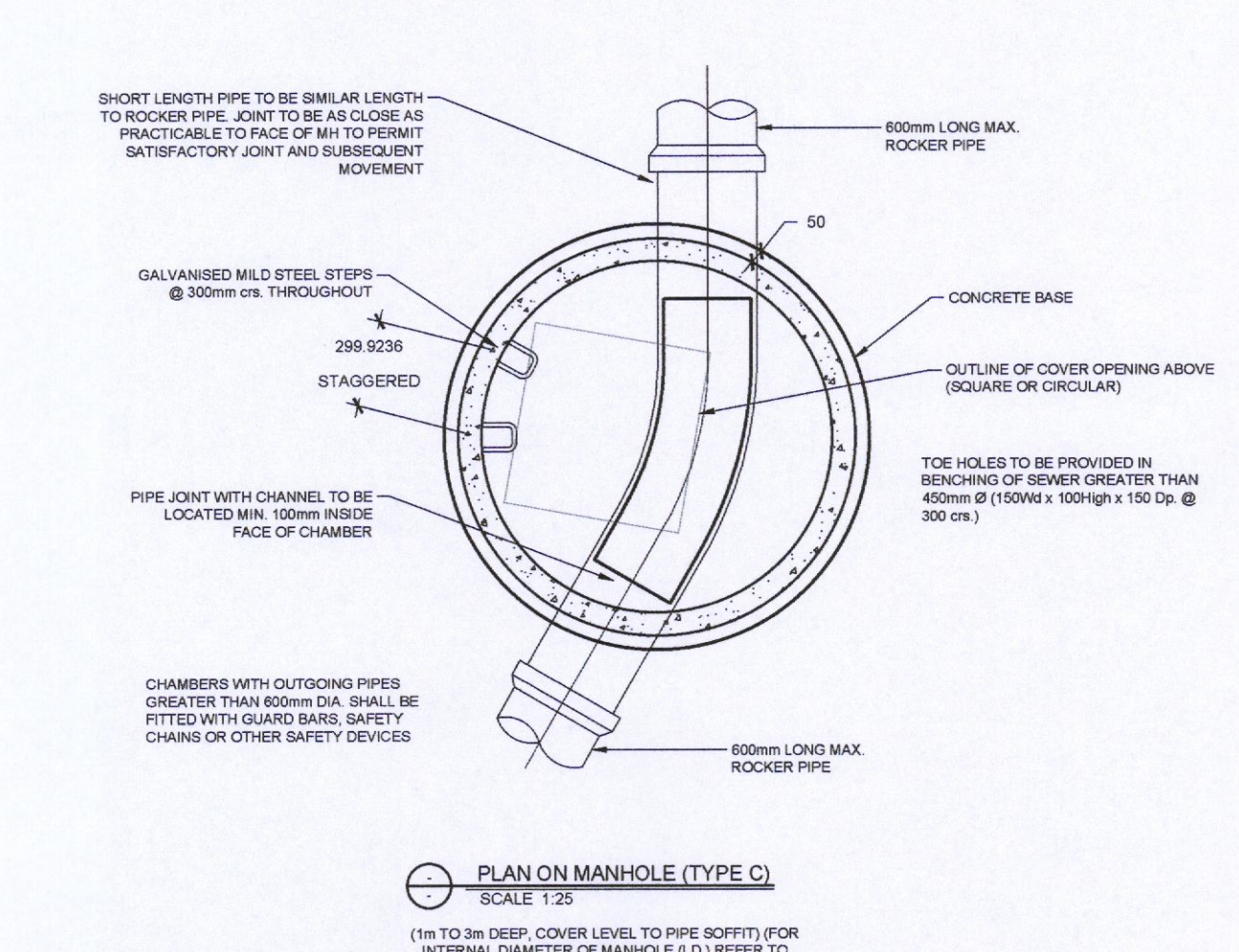
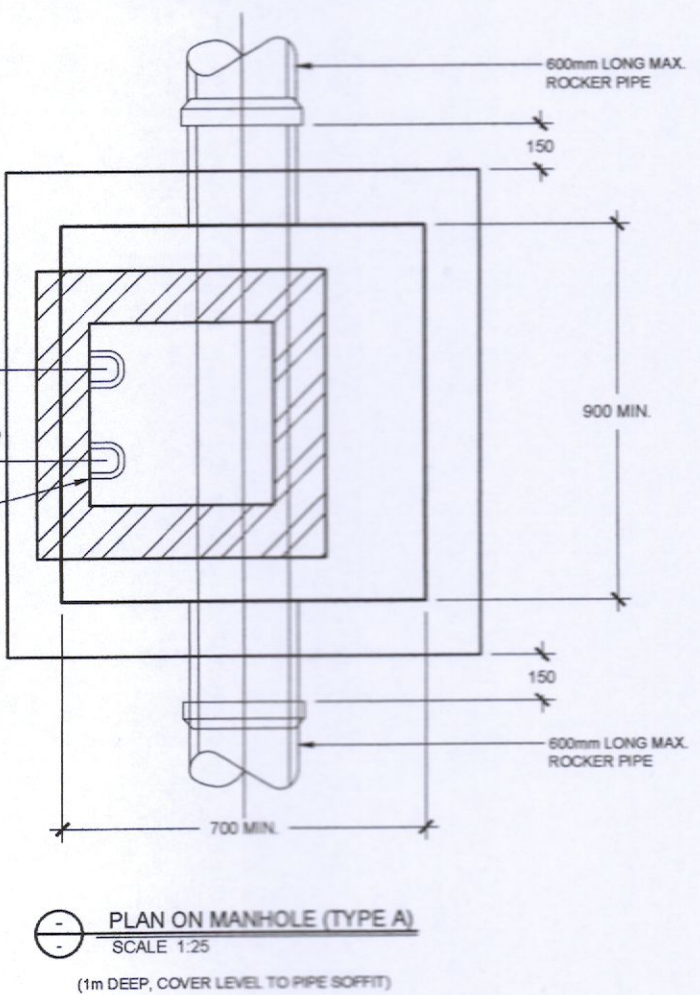
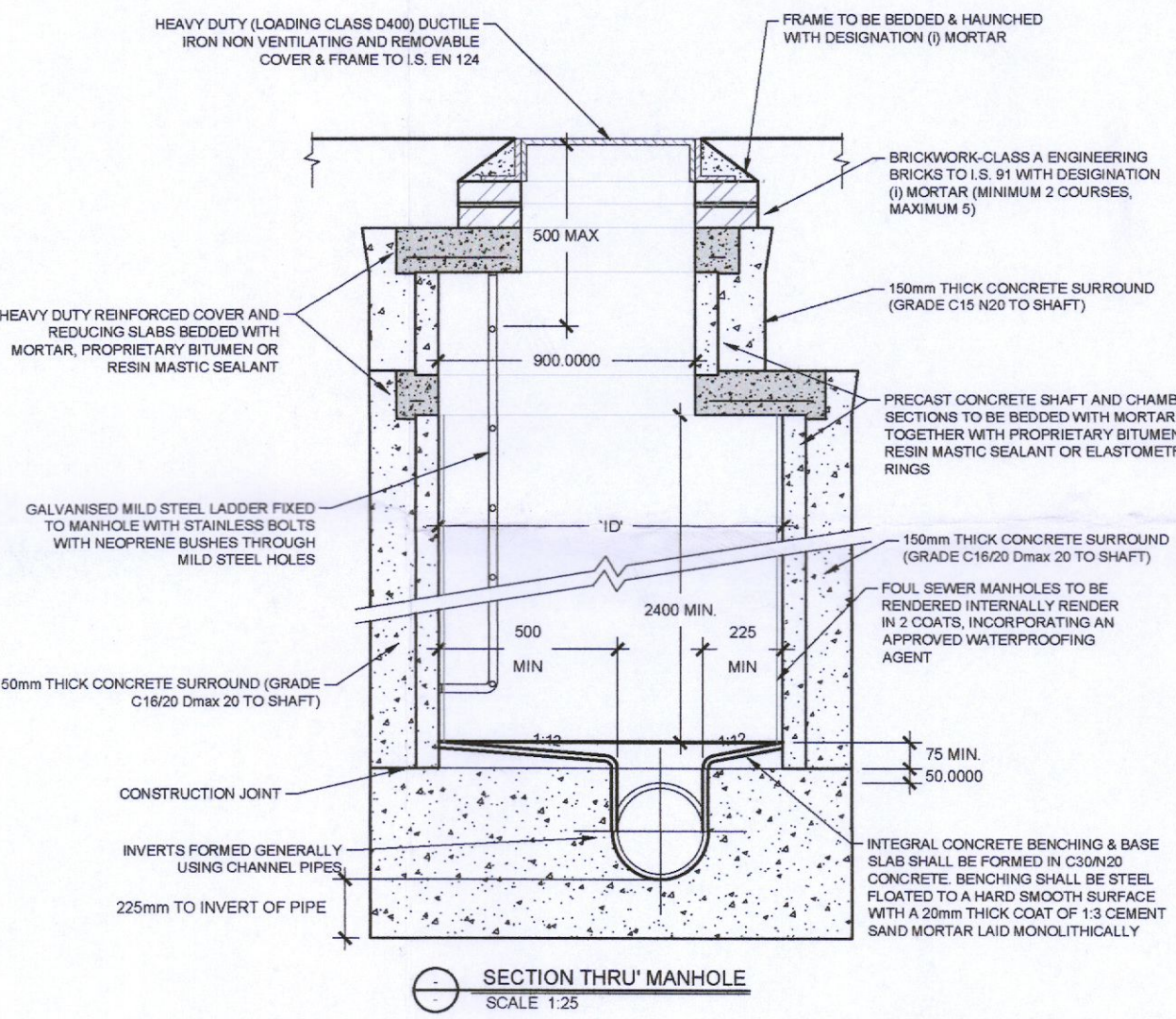
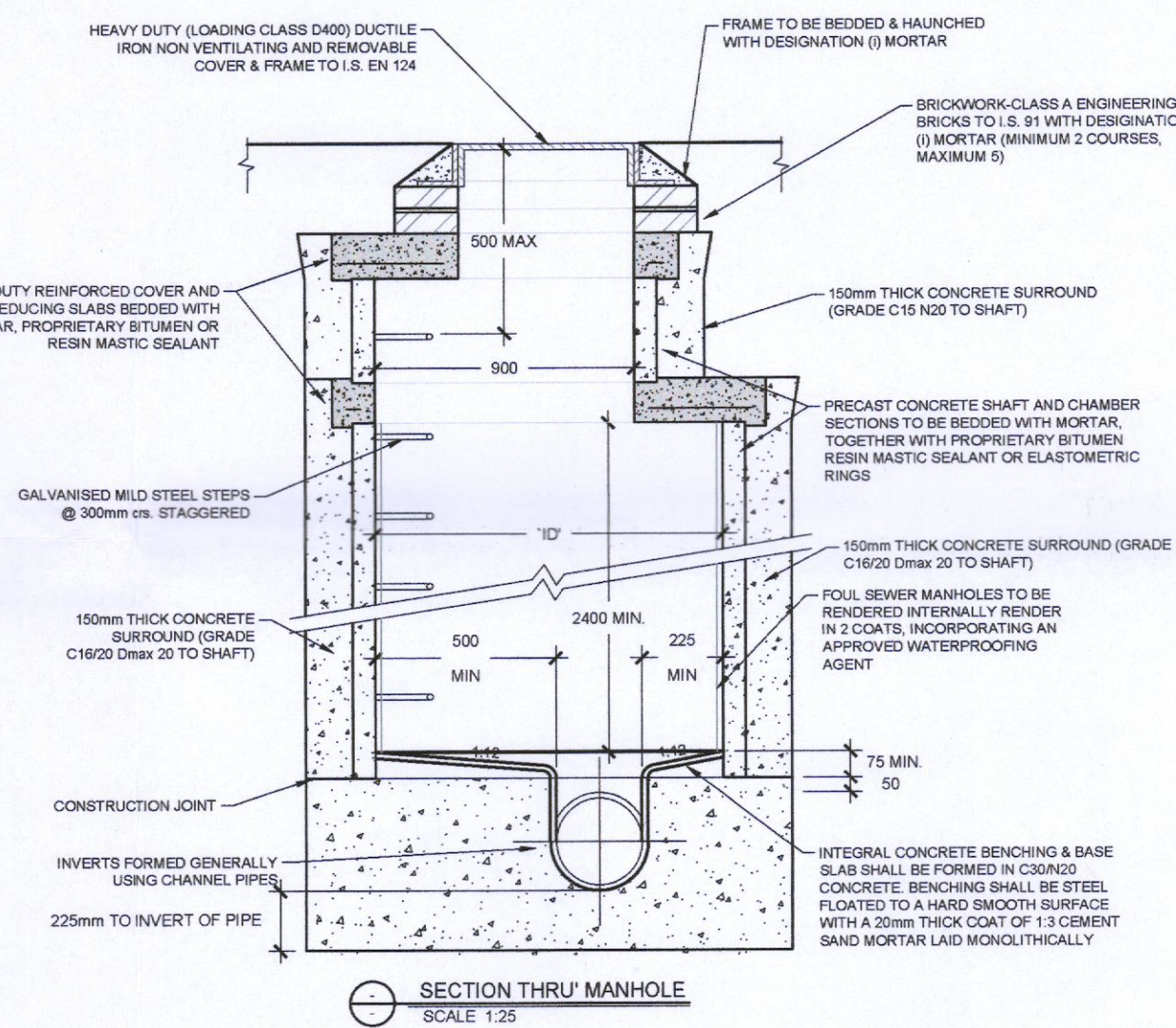
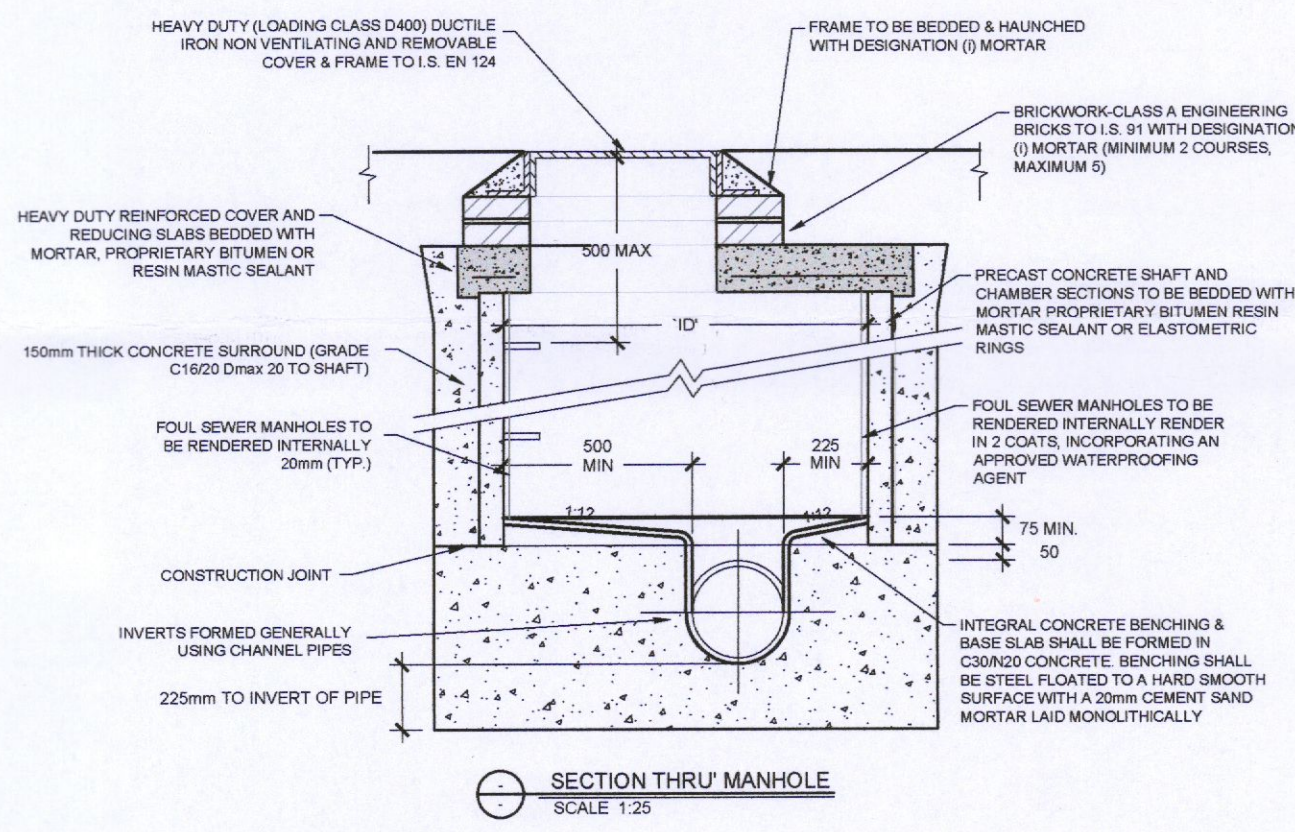
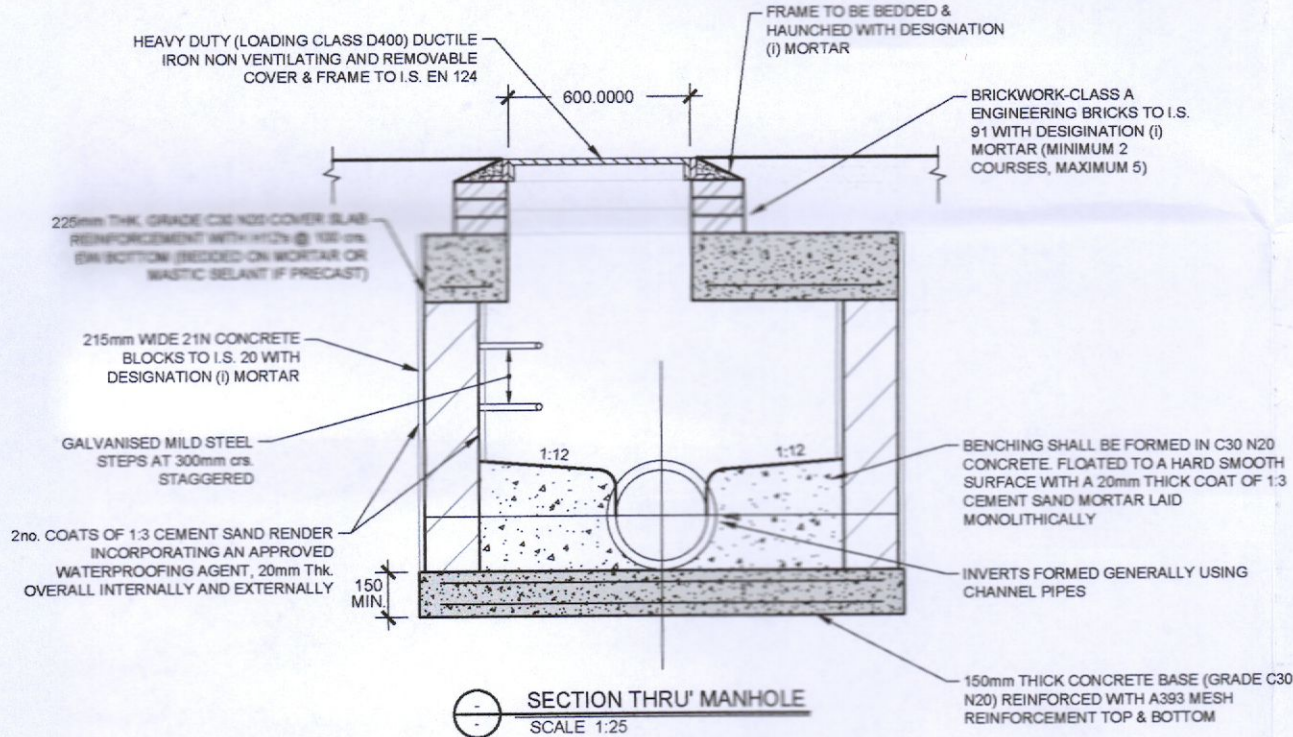

Drawing Stage:  <b>PLANNING</b>	Project Details:	
	Site Address:	CUCKOO'S NEST, GREENHILLS ROAD KILNAMANAGH, DUBLIN 24
	Client:	-
	Architect:	DAVEY SMYTH ARCHITECTS
	M&E Designer:	-
Contractor:	-	

Notes			
Drawn by:	Checked by:	Approved by:	Date:
JÓB	JMcM	JMcM	30-11-2022
Project Name:	Scale:	Project Number:	
CUCKOO'S NEST	N.T.S.	21816	
Drawing Title:	Project:	Originator:	Zone:
DRAINAGE DETAILS, SHEET 1	21816	CORA	ZZ
	Level:	Type:	Discipline:
	ZZZ	DR	C
	Drawing No:	Stage:	Revision:
	103	PL	01

Behan House,  
10 Lower Mount Street,  
Dublin 2. D02 HT71  
Tel: +353 1 661 1100  
e-mail: info@cora.ie  
Web: www.cora.ie

**CORA**  
CONSULTING ENGINEERS