

**Figure 3-2 Site Topography / Main Drainage Features**



## 4. PROPOSED DEVELOPMENT

### 4.1 Description

The proposed development comprises industrial buildings, parking areas, circulation roads, ancillary landscaping, drainage (including SUDS measures), services and ancillary site works.

The development will consist of the demolition of the two storey dwelling (207.35sqm) and associated outbuildings and farm structures (348.36sqm); and the construction of 1 no. two storey data center with plant at roof level and associated ancillary development that will have a gross floor area of 12,893sqm that will consist of the following:

- 1 no. two storey data center (Building 13) with a gross floor area of 12,893sqm. It will include 13 no. emergency back-up generators of which 12 will be double stacked and one will be single stacked within a compound to the south-western side of the data center with associated flues that each will be 22.316m in height and 7 no. hot-air exhaust cooling vents that each will be 20.016m in height;
- the data center will include data storage rooms, associated electrical and mechanical plant rooms, loading bays, maintenance and storage spaces, office administration areas, and plant including PV panels at roof level as well as a separate house generator that will provide emergency power to the admin and ancillary spaces. Each generator will include a diesel tank and there will be a refuelling area to serve the proposed emergency generators;
- The data center will have a primary parapet height of 14.246m above ground level, with plant and screen around plus a plant room above at roof level. The plant room has an overall height of 21.571m;
- Construction of an internal road network and circulation areas, with a staff entrance off Falcon Avenue to the east, as well as a secondary vehicular access for service and delivery vehicles only across a new bridge over the Baldonnel Stream from the permitted entrance as granted under SDCC Planning Ref. SD21A/0241 from the south-west, both from within Profile Park that contains an access from the New Nangor Road (R134);
- Provision of 60 no. car parking spaces (to include 12 EV spaces and 3 disabled spaces), and 34 no. cycle parking spaces;
- Signage (5.75sqm) at first floor level at the northern end of the eastern elevation of the data center building; and

- Ancillary site development works, will include footpaths, attenuation ponds that will include an amendment to the permitted attenuation pond as granted to the north of the Baldonnel Stream under SDCC Planning Ref. SD21A/0241, as well as green walls and green roof. The installation and connection to the underground foul and storm water drainage network, and installation of utility ducts and cables, that will include the drilling and laying of ducts and cables under the internal road network within Profile Park. Other ancillary site development works will include hard and soft landscaping that will include an amendment to the permitted landscaping as granted under SDCC Planning Ref. SD21A/0241, lighting, fencing, signage, services road, entrance gates, and sprinkler tanks.

A schematic layout for the proposed development is shown in Figure 4-1. Relevant proposals for the development are shown on the schedule of documents contained in Appendix A.



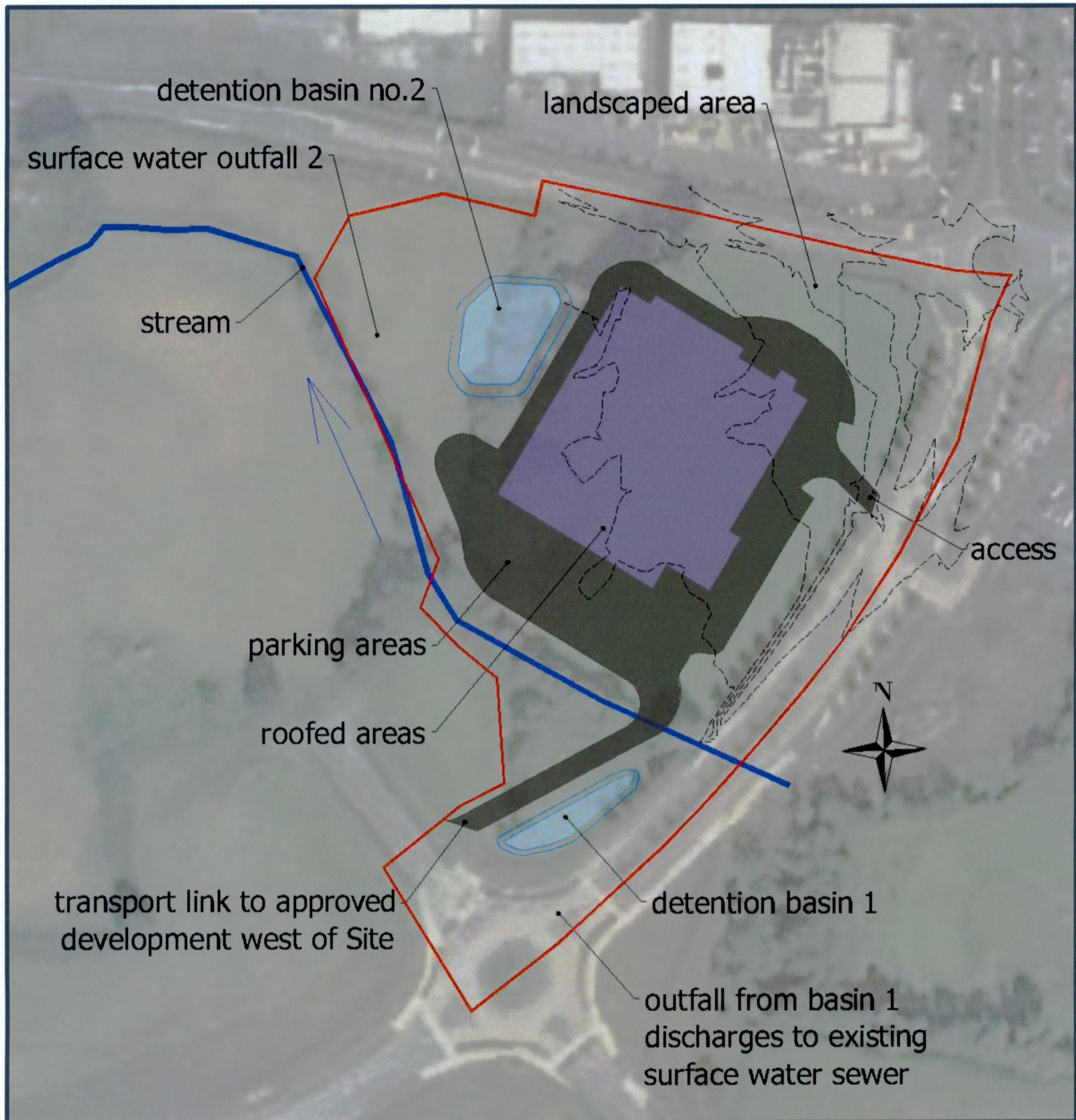

**Figure 4-1 Schematic Layout of Proposed Development**

**4.2 Vulnerability**

Table 3.1 of the Guidelines classifies different types of development in terms of their vulnerability to flooding. Figure 4-2 contains an extract from this table which shows industrial development classified as Less Vulnerable. The proposed development is an industrial development and so falls under this classification.



Less vulnerable development Buildings used for: retail, leisure, warehousing, commercial, industrial and non-residential institutions; Land and buildings used for holiday or short-let caravans and camping, subject to specific warning and evacuation plans; Land and buildings used for agriculture and forestry; Waste treatment (except landfill and hazardous waste); Mineral working and processing; and Local transport infrastructure.
--

**Figure 4-2 Classification of development type by vulnerability to flooding**

Table 3.2 of the Guidelines provides a matrix of development vulnerability versus Flood Zone which illustrates the appropriateness of a development type for each Flood Zone. This table is reproduced in Figure 4-3 and shows the Guidelines regards Less Vulnerable development as being appropriate for Sites in Flood Zone B and requiring the Justification Test for Sites in Flood Zone A

Flood Zone A	Flood Zone B	Flood Zone C
Highly vulnerable development (including essential infrastructure)	Justification Test	Justification Test
Less vulnerable development	Justification Test	Appropriate
Water-compatible development	Appropriate	Appropriate

**Figure 4-3 Matrix of vulnerability versus Flood Zone**

Table 3.2: Matrix of vulnerability versus flood zone to illustrate appropriate development and that required to meet the Justification Test.



## 5. FLUVIAL FLOOD RISK – INITIAL ASSESSMENT

### 5.1 Flood Risk Indicators - Desktop

A number of datasets were interrogated for indicators of fluvial flood risk:

(i) *SFRA*

Mapping prepared as part of the Strategic Flood Risk Assessment for the South Dublin County Development Plan indicates the Site is not affected by either the 0.1% AEP and 1.0% AEP flood events. The only exception is at the southern corner where the existing Park Road is shown to be subject to flood risk. An extract from this mapping is shown in Figure 5-1.

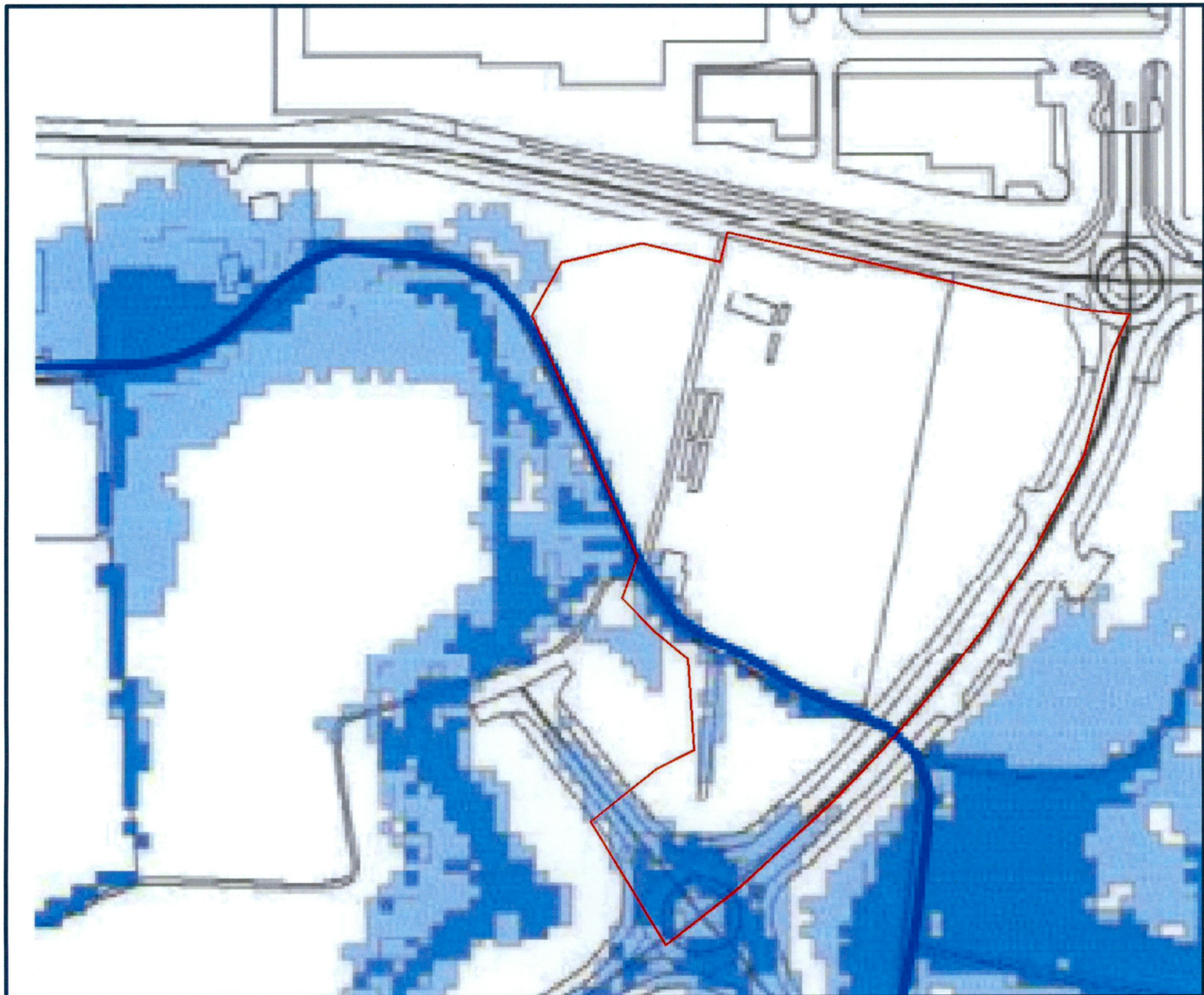

**Figure 5-1 Extract from SFRA showing fluvial flood risk at the Site**



(iii) OPW National Flood Hazard Mapping Website

The OPW maintains the National Flood Hazard Mapping website (floodinfo.ie) which contains information about locations that may be at risk from flooding. The source of this information includes Local Authorities and other historic records such as newspaper articles and other documentation about reported floods.

The website does not have any records of flooding at this location.

(iiii) CFRAM

Mapping prepared as part of the CFRAM programme indicates the Site is not affected by the 0.1% AEP flood event but not the 1.0% AEP event. As with SSFRA mapping, the only exception is at the southern corner where the existing Park Road is shown to be subject to flood risk. An extract from this mapping is shown in Figure 5-2.

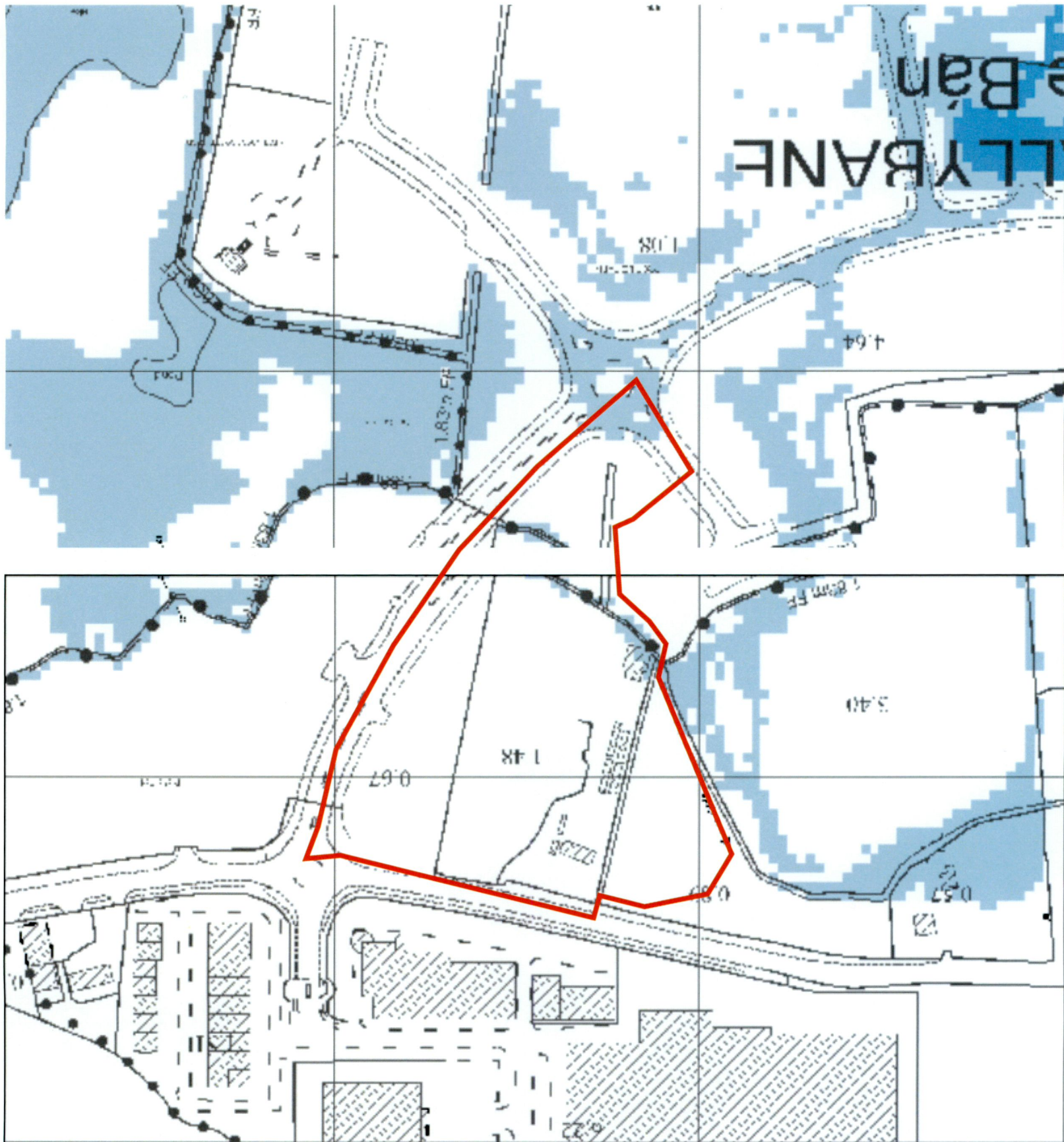
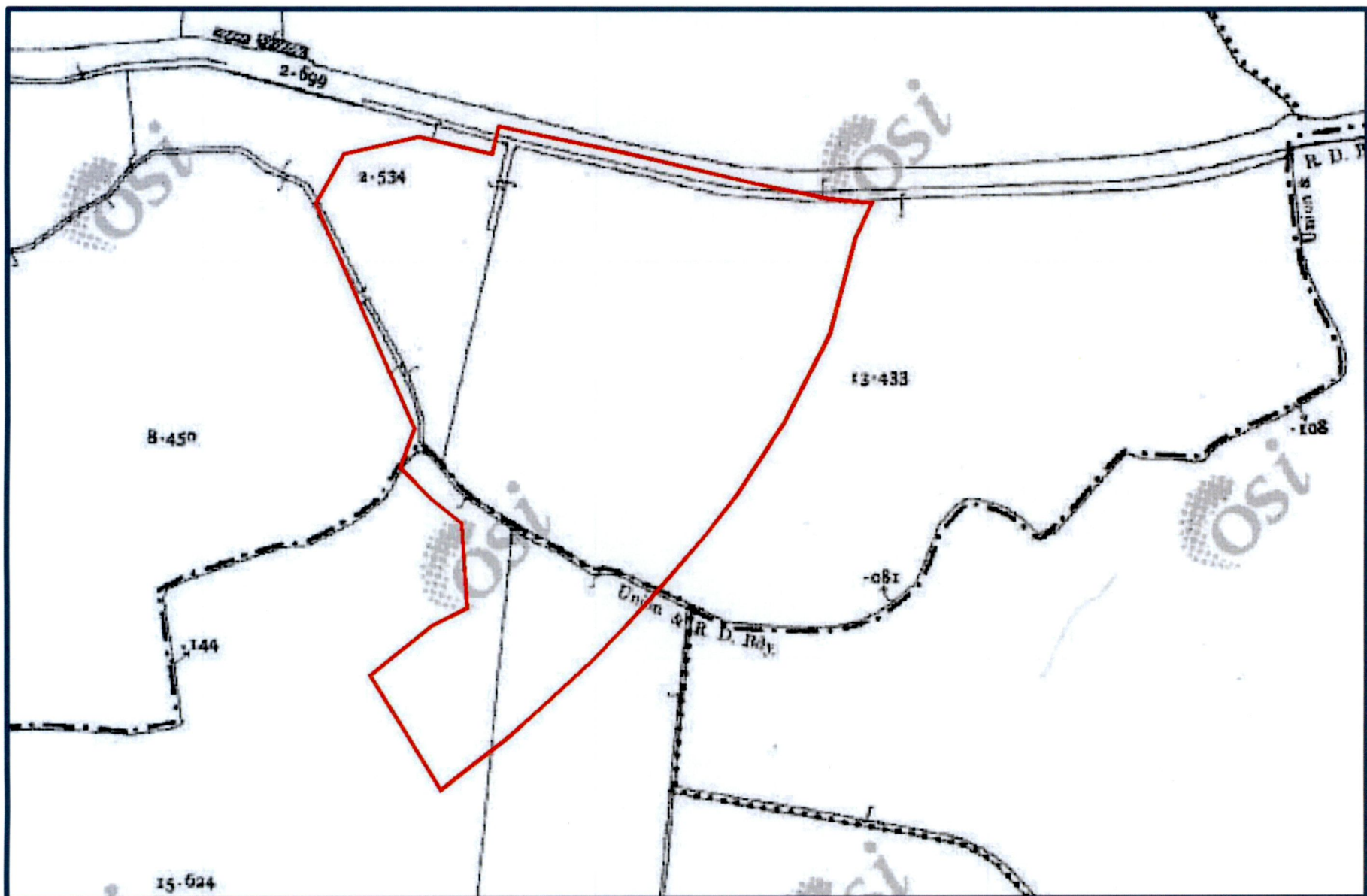

Figure 5-2 Extract from CFRAM mapping showing fluvial flood risk at the Site



*(iv) Ordnance Survey Mapping*

Figure 5-3 shows the historic 25" OS mapping for the Site and its immediate surroundings. There is no indication of flood risk at the Site.



**Figure 5-3 Historic OS Map**

## 5.2 Flood Risk Indicators - Site Walkover

The Baldonnell Stream [‘the Stream’] crosses under the Park Road through a twin-pipe culvert, each pipe 1400mm diameter, and enters the Site close to its southern boundary.

The Baldonnell Stream flows through the Site for approximately 45m and then exits the Site at its west boundary.

190m downstream of the Site the Stream flows through a short 600mm dia. culvert.

300m downstream of the Site, the Stream discharges to a long twin-pipe culvert. The inlet to this culvert is poorly constructed and hydraulically inefficient; it was observed that in addition to the pipes, the gaps between the pipes also provides a flow path for the stream to discharge to.

A visual assessment of the channel of the stream suggests the twin-pipe culvert will have a significantly lower hydraulic capacity than the channel.





Figure 5-4 View of Site at East Boundary from North



Figure 5-5 View of Site at West Boundary from North





**Figure 5-6 View of Site at West Boundary from South**



**Figure 5-7 Upstream View of Culvert under Park Road**



Report on Site-Specific Flood Risk Assessment

---

Figure 5-8 Typical View of Stream Channel through Site







**Figure 5-7 Typical Section of Stream Channel downstream of Site**



**Figure 5-8 Inlet to twin-pipe culvert**



Report on Site-Specific Flood Risk Assessment

---

**5.3 Initial Assessment**

The indicators described in Section 5.1 suggest the Site is not at significant risk from fluvial flooding. However, the Site Walkover suggests the Site may be at risk of flooding caused by inadequate hydraulic culvert capacity downstream of the Site. Accordingly, it is the conclusion of this SSFRA that detailed assessment of fluvial flood risk is appropriate.

---

Proposed Industrial Development, DUB13, Profile Park, Grangecastle, Co. Dublin



## 6. FLUVIAL FLOOD RISK – DETAILED ASSESSMENT

### 6.1 Estimating Peak Flood Flows

The catchment area for the stream, shown outlined blue on Figure 6-1, measures 1.0 km<sup>2</sup>.



**Figure 6-1 Catchment Area for Stream**



The OPW provides a Web Portal for estimating peak flood flows in natural catchments (Flood Studies Update (FSU) Web Portal). While the use of this portal is generally considered best practice for the estimation of flood flows, the portal advises particular caution where peak flows are being estimated for catchments of less than 25km<sup>2</sup>. Accordingly, peak flood flows were estimated using statistical methods for ungauged small catchments.

Table 6-1 shows a number of Physical Catchment Descriptors taken from the FSU portal that were used to estimate peak flood flows.

PCD	Value
BFISOIL	0.5199
SAAR	714.82 mm
FARL	1
DRAIND	0.721 km/km <sup>2</sup>
S1085	0.1 m/km
ARTDRAIN2	0
ARTDRAIN2	0
URBEXT	0.3589

**Table 6-1 Physical Catchment Descriptors from FSU Web Portal**

Initially, various alternative statistical methods were used and the results of these are reproduced in Table 6-2 (details of these calculations are included in Appendix B). All flow estimates include a climate change factor of 20%.

Typically, peak flow estimates for the 1% AEP flood event are below 1.0m<sup>3</sup>/s. The only exception is the flow estimate given by IH124 which is over three times the next greatest estimate and not consistent with the size of the catchment and the drainage infrastructure in the area. IH124 is generally considered to over-estimate peak flood flows {WP4.2 Flood Estimation in Small and Urbanised Catchments – OPW 2012}. Therefore, the IH124 flow estimate will not be used and instead the flow estimates used will be the next greatest; i.e. those given by the FEH-Statistical method.



Method	1% AEP	0.1% AEP
	m <sup>3</sup> /s	m <sup>3</sup> /s
IH124	2.79	3.69
FSU Update	0.47	0.64
FSU-3V	0.14	0.18
FSU_7V	0.37	0.51
FEH-Statistical	0.89	1.20

**Table 6-2 Estimates for Peak Flood Flows**

**6.2 Pre-development Hydrological Model**

A hydrological model was prepared to simulate flow patterns during the 1% and 0.1% AEP rainfall events. This model was developed using the River and Flood Analysis module of the industry standard package Infrastructure Ultimate Design Suite produced by Autodesk. The hydrological modelling within this module is itself based on the HEC-RAS modelling software produced by the US Army Corps of Engineers.

The module calculates flood risk zones for the catchment based on the peak flood flows and the following:

- a terrain model created using topographical survey data;
- dimensions of culverts and other drainage structures;
- appropriate values for the roughness coefficient 'Manning's n' as determined from visual inspection of the Site.

Culvert downstream of Site

As described above, the stream is culverted downstream of the Site. This culvert comprises two 600mm diameter pipes at its inlet. A CCTV survey of the culvert revealed that one of the pipes changes to 450mm diameter approximately 20m from the inlet. Furthermore, both pipes show significant blockages that greatly reduce the capacity of the culvert; the extent of these blockages was such that the survey could not be completed for the full length of the culvert.

In regard to this culvert, the hydraulic models assumes:

- the culvert comprises a 600mm dia. pipe and 450mm dia. pipe for its entire length;
- the culvert will be cleared of all obstructions and maintained free of debris / deposition throughout the operational life of the proposed development;
- the maximum depth of deposition in the culvert will be 100mm.

Pre-Development Fluvial Flood Risk Zones at the Development Site

The map in Figure 6-2 shows the existing fluvial flood risk zones determined using the hydrological model described above. Peak water levels are as follows:

- 1.0% AEP Flood Event 72.15 m;
- 0.1% AEP Flood Event 72.53 m.

The Site was found to be not affected by either 1% or 0.1% AEP flood risk zones.



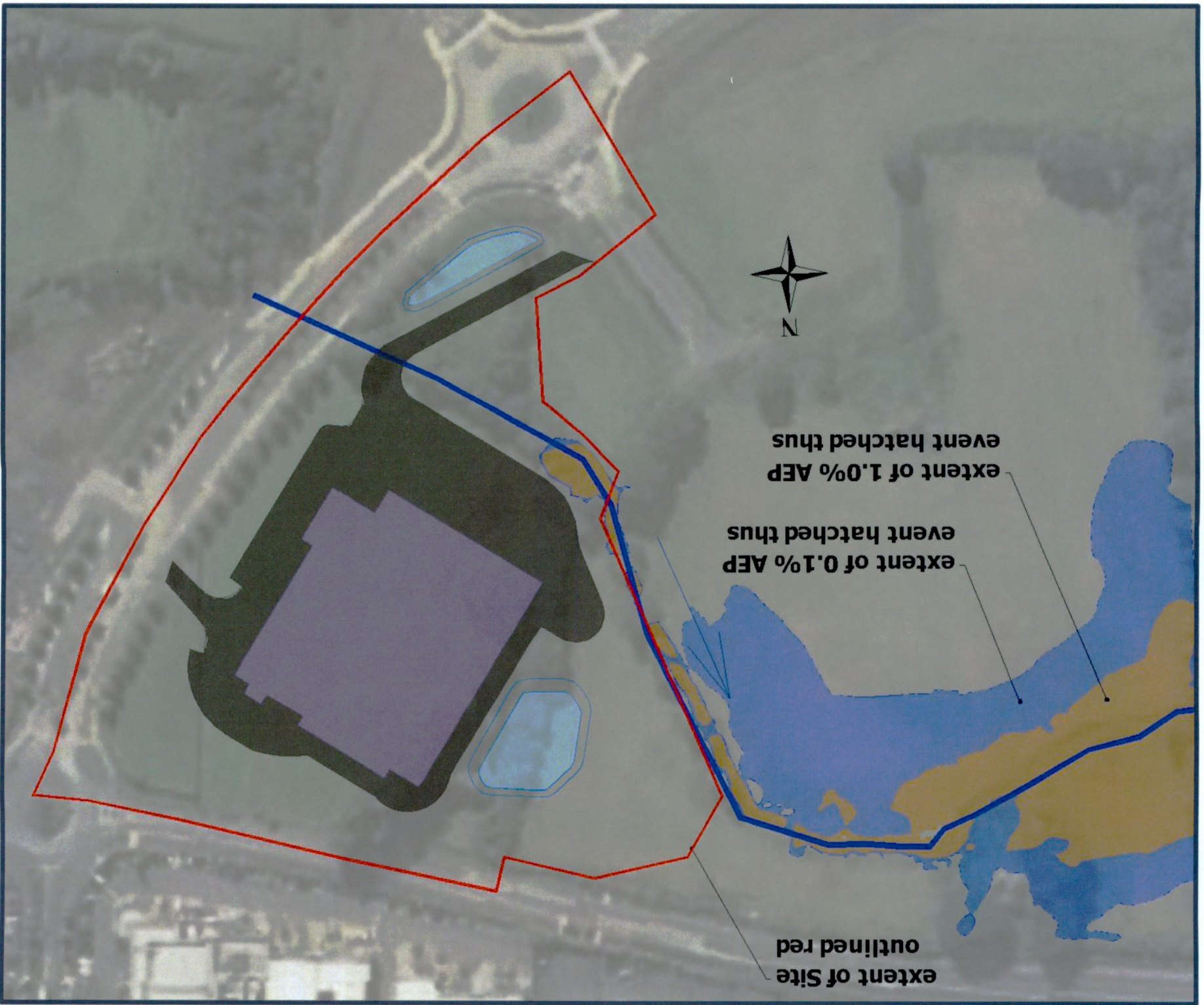

Figure 6-2 Fluvial flood risk zones - Pre-Development

### 6.3 Development Proposals - Surface Water Drainage

The surface water drainage system for the proposed development has been designed by Pinnacle Consulting Engineers who have provided design calculations demonstrating compliance with the Greater Dublin Strategic Drainage Study in the schedule of documents listed in Appendix A.

Full compliance with GSDS ensures the drainage system ensures the flood regime in the receiving stream will not be affected, thus not giving rise to flood risk elsewhere.

### 6.4 Development Proposals - Road crossing of Baldonnell Stream

As described in Section 5.2, the Stream crosses under the Park Road through a twin-pipe culvert, each pipe 1400mm diameter. The proposed road crossing is 20m downstream from the Park Road culvert.

Figure 6-3 shows a box culvert to convey the Stream under the proposed crossing.

The internal dimensions of the box culvert are 1.4m in height and 3.5m in width and it thus has a significantly greater hydraulic capacity than that of the Park Road culvert.



To meet the requirements of the Office of Public Works (OPW) for granting Section 50 approval under the Arterial Drainage Act, culverts are typically required to have a minimum 300mm clearance between the 1% AEP water level and the soffit of the culvert. Figure 6-3 shows the box culvert will have 650mm clearance between the 1% AEP water level and the soffit level, thus comfortably exceeding OPW requirements.

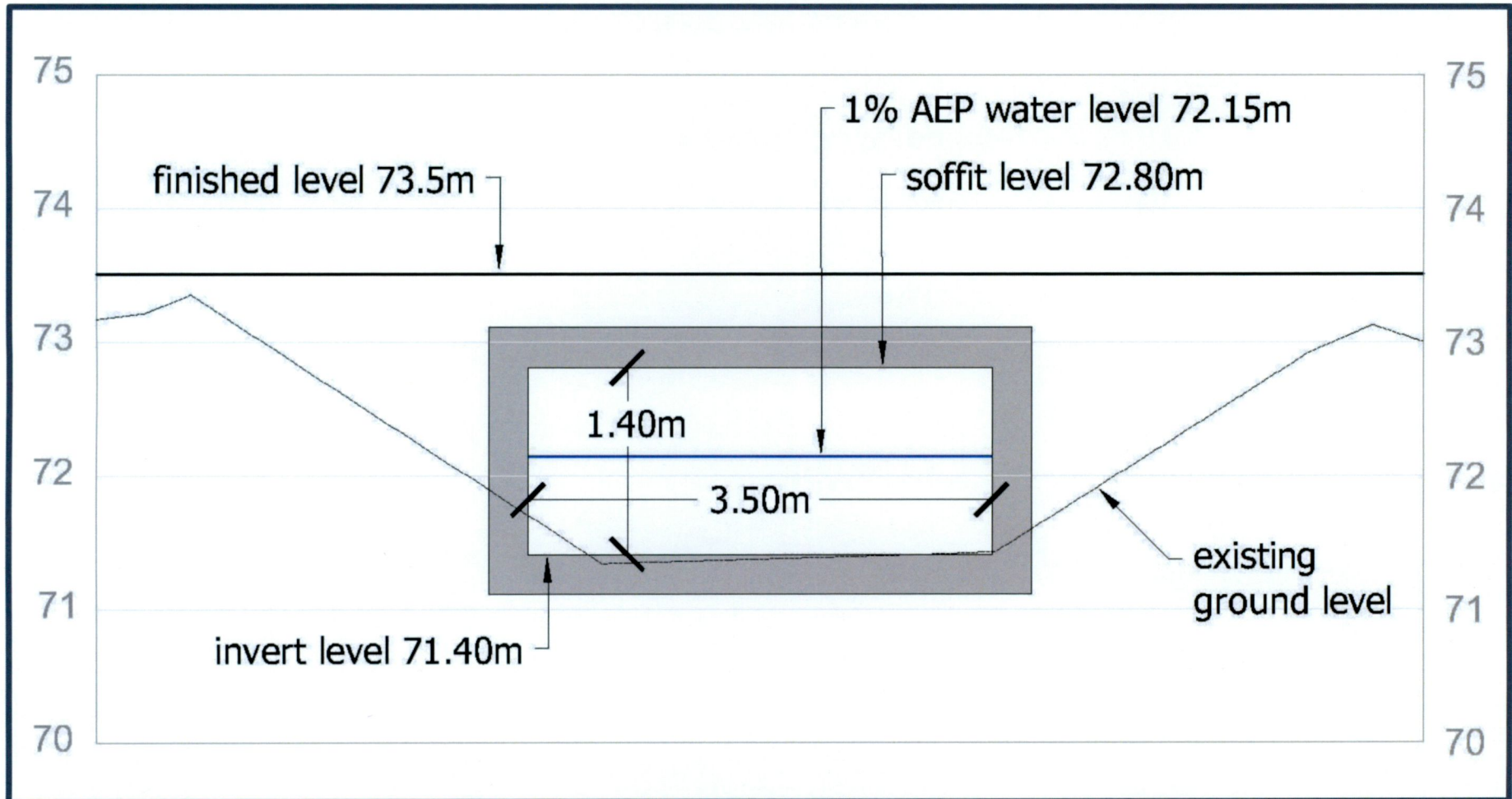

**Figure 6-3 Fluvial flood risk zones - Pre-Development**

**6.5 Conclusion of Detailed Assessment of Fluvial Flood Risk**

The proposed development will not be at risk of flooding from fluvial sources and will not give rise to fluvial flood risk elsewhere.



**7. FLOOD RISK FROM GROUNDWATER**

**7.1 Flood Risk Indicators - Desktop**

Various datasets were interrogated for indicators of flood risk from Ground Water. These comprise:

- (i) *OPW National Flood Hazard Mapping*  
Records from the National Flood Hazard Mapping website maintained by the OPW do not contain any evidence of flood events at the Site associated with fluctuations in groundwater level;
- (ii) *Geological Survey of Ireland (GSI)*  
The GSI maintains a web portal that provides data for Groundwater (<https://www.gsi.ie>), including groundwater flooding data.  
The portal does not show any groundwater flooding at or in the vicinity of the Site.  
The portal indicates the Site to be in an area of high groundwater vulnerability with subsols of low permeability.
- (iii) *Historical Ordnance Survey Mapping*  
Historical OS maps shows a well immediately northwest of the Site. No other information is available for this well. There is no indication of springs at the Site.

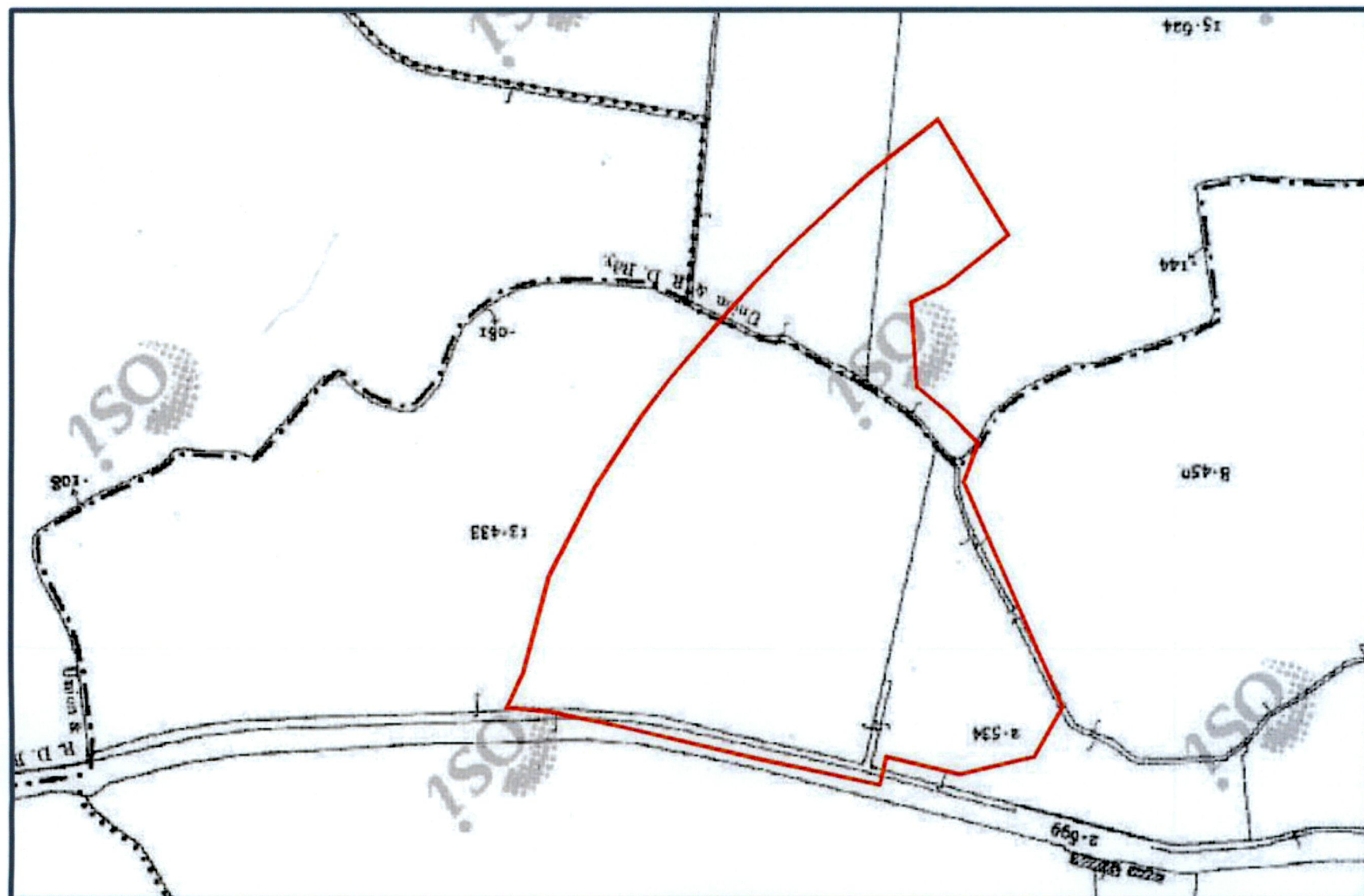

**Figure 7-1 Historic OS Mapping**

- (iv) *Ground Investigation*  
A ground investigation at the Site encountered groundwater generally between 1.0m and 2.0m blow existing ground level.
- (v) *Topography*



The topography of the Site does not include localised low-lying areas that would give rise to groundwater ponding to a significant depth.

### **7.2 Flood Risk Indicators – Site Walkover**

No evidence of flood risk from groundwater was observed during a Site walkover.

### **7.3 Initial Assessment**

The ground investigation did encounter water-bearing strata relatively close to the surface however all indicators suggest the Site is not at risk from groundwater flooding. Detailed assessment of flood risk from this mechanism is not required.



## 8. PLUVIAL FLOOD RISK

### 8.1 Flood Risk Indicators - Desktop

A number of datasets were interrogated for indicators of pluvial flood risk:

(i) SFR4

The Strategic Flood Risk Assessment for the South Dublin County Council does not contain any information regarding pluvial flood risk at the Site.

(ii)

*OPW National Flood Hazard Mapping Website*

The OPW maintains the National Flood Hazard Mapping website (floodinfo.ie) which contains information about locations that may be at risk from flooding. The source of this information includes Local Authorities and other historic records such as newspaper articles and other documentation about reported floods. This source does not register any previous flood events associated with pluvial flood risk at the Site.

(iii)

*CFRAM study programme undertaken by the OPW*

Maps prepared for the CFRAM study programme do not show any pluvial flood risk at the Site.

(iv)

*Urban Drainage Systems*

The Site is not affected by urban drainage systems that would give rise to overland flow across the Site.

### 8.2 Flood Risk Indicators – Site Walkover

No indicators of pluvial flood risk were observed during a site walkover

### 8.3 Surface water drainage system for the proposed development

The surface water drainage system for the proposed development has been designed by Pinnacle Consulting Engineers to comply with the Greater Dublin Strategic Drainage Study.

Full compliance with GSDS ensures the drainage system will have sufficient capacity to accommodate rainfall events up to 1% AEP (including climate change) without causing pluvial flood risk within the development and without leading to an increase in pluvial flood risk elsewhere

### 8.4 Initial Assessment

Based on the indicators described in Section 8.1, on the site walkover described in Section 8.2 and the design of the surface water drainage system as described in Section 8.3, the initial assessment indicates the Site is not at risk from pluvial flooding and further assessment is not required.



## **9. RESIDUAL FLOOD RISK**

Residual risk is the risk that remains after all mitigation measures to reduce the frequency of flooding have been taken.

### **9.1 Flood Risk Management Plan**

The assessment to this point has found the proposed development is not at risk of flooding. However, all developments include some element of residual flood risk that must be addressed during their operational lives; for example the failure of building drainage due to lack of maintenance.

To address this residual risk, it is recommended that a Site-Specific Flood Risk Mitigation Plan prepared in accordance with the Guidelines is implemented throughout the operational life of the proposed development.

### **9.2 Blockage in culvert immediately downstream of the Site**

As described already, the stream is culverted downstream of the Site. This culvert comprises two 600mm diameter pipes at its inlet. A CCTV survey of the culvert revealed that one of these pipes changes to 450mm diameter approximately 20m from the inlet. Furthermore, the CCTV survey found both pipes to have significant blockages that greatly reduce the overall capacity of the culvert; the extent of these blockages was such that the survey could not be completed for the full length of the culvert.

Therefore, the condition and size of the culvert downstream of the blockages is unknown and there is potential, for example in the event of culvert collapse, of the stream surcharging within the Site to a level exceeding that predicted by the hydrological models. To mitigate this risk, it is recommended that an overflow be constructed from the Site which would allow such excess to discharge to the stream immediately downstream of the Nangor Road. Subject to the capacity being available, this overflow could possibly discharge to existing surface water drainage in the Nangor Road but a dedicated surface water pipe might be required from the Site to a new outfall downstream of the Nangor Road.

The Flood Risk Mitigation Plan described in Section 9.1 must include should include a maintenance regime for all drainage features within the Site and for regular inspection of drainage features immediately upstream and downstream of the Site.



## 10. MINIMUM FINISHED LEVELS

In order to ensure that elements of development of the Site not compatible with water (i.e. roads, buildings etc.) are not at risk of flooding, the Guidelines recommend that floor levels and road levels be kept above the 1% AEP flood level with an appropriate allowance for freeboard.

A freeboard of 500mm is appropriate for floor levels and a freeboard of 250mm is appropriate for road levels. The maximum water level during the 1% AEP flood event is 72.15m. The minimum floor level is 74.00m and the minimum parking level is 73.45m and so both meet the recommendations of the Guidelines.



**11. DEVELOPMENT MANAGEMENT JUSTIFICATION TEST**

A Development Management Justification Test was carried out in respect of the proposed development in accordance with Section 5.15 of the Flood Risk Management Guidelines and incorporating the findings of the subject FRA. Table 11.1 presents the results of this test which conclude that the proposed development satisfies the criteria of the Justification test.

1.1	<i>The subject lands have been zoned or otherwise designated for the particular use or form of development in an operative development plan, which has been adopted or varied taking account of these Guidelines.</i>	
	Yes	
1.2	<i>The proposal has been subject to an appropriate flood risk assessment which demonstrates that :</i>	
	(i)	<i>the proposed development will not increase flood risk elsewhere and, if practicable, will reduce overall flood risk;</i>
		Yes
	(ii)	<i>the proposed development includes measures to minimise flood risk to people, property, the economy and the environment as far as reasonably possible;</i>
		The proposed development includes proposals for treating and controlling surface water discharge which, will minimise flood risk to people, property, the economy and the environment as far as reasonably possible.
	(iii)	<i>the proposed development includes measures to ensure that residual risks to the area and/or development can be managed to an acceptable level as regards the adequacy of existing flood protection measures or the design, implementation and funding of any future flood risk management measures and provisions for emergency services access;</i>
		The proposed development does not impact on any existing flood protection measures and will not prevent possible future flood risk management measures.
	(iv)	<i>the proposed development addresses the above in a manner that is also compatible with the achievement of wider planning objectives in relation to development of good urban design and vibrant and active streetscapes.</i>
	Yes.	

**Table 11.1 Justification Test**



---

 Report on Site-Specific Flood Risk Assessment
 

---

Recommendations arising from assessment of residual flood risk

All developments include some element of residual flood risk that must be addressed during their operational life. To address this residual risk, it is recommended that a Site-Specific Flood Risk Mitigation Plan prepared in accordance with the Guidelines is implemented throughout the operational life of the proposed development. This plan should include a maintenance regime for all drainage features within the Site and for regular inspection of drainage features immediately upstream and downstream of the Site.

The detailed assessment of fluvial flood risk concluded the proposed development will not be at risk of flooding from fluvial sources and will not give rise to fluvial flood risk elsewhere.

Finished levels for buildings and roads in the proposed development provide an appropriate freeboard above the 1% AEP water level in accordance with the Guidelines.

The proposed development includes a road crossing of the Park Road culvert. A box culvert with internal dimensions of 1.4m in height and 3.5m can installed at this crossing and would provide a significantly greater hydraulic capacity than that of the Park Road culvert and comfortably exceed OPW requirements for clearance between the soffit level of the culvert and the 1% AEP water level.

The surface water drainage system for the proposed development has been designed by Pinnacle Consulting Engineers in compliance with the Greater Dublin Strategic Drainage Study. Full compliance with GDSDS ensures the drainage system ensures the flood regime in the receiving stream will not be affected, thus not giving rise to flood risk elsewhere.

The detailed assessment of fluvial flood risk confirmed the Site is not affected by Flood Risk Zone A (the 1% AEP flood event) and to a greater extent by Flood Risk Zone B (the 0.1% AEP flood event).

Detailed assessment of fluvial flood risk

Initial assessment of flood risk indicators suggest the Site could be at risk from Fluvial Flooding during the 1.0% AEP and 0.1% AEP events. Accordingly, a detailed assessment of fluvial flood risk was carried out.

Initial assessment of existing flood risk indicators indicate the Site is not at risk from either Fluvial or Groundwater flooding. The designers of the surface water drainage system have confirmed the surface water drainage system for the proposed development is designed in accordance with the Greater Dublin Strategic Drainage Study and so will be sufficient to ensure surface water run-off from the proposed development will cause flood risk within the proposed development and will not give rise to flood risk elsewhere.

For an inland Site of this nature and for which there are no existing flood defence mechanisms that could affect flood risk at the Site, the potential flood risk mechanisms are Fluvial, Pluvial, Groundwater and failure of drainage infrastructure (assessed as a residual risk).

Initial assessment

The SSFRA was carried out in accordance with the document 'Planning System and Flood Risk Management – Guidelines for Planning Authorities' [the Guidelines].

This report presents the findings of a Site-specific flood risk assessment (SSFRA) carried out by Kilgallen and Partners in regard to proposed development on lands to the south of the New Nangor Road (R134), Dublin 22 and on land within the townlands of Ballybane and Kilbride within Profile Park, Clondalkin, Dublin 22 on an overall site of 3.79hectares [the Site].

## 12.1 Summary

## 12. SUMMARY AND CONCLUSION