

TANK TYPE: CH FORECOURT INTERCEPTORS
 TANK SIZE: 4130mm X 2340mm (OVERALL)
 HEIGHT: 2350mm
 VOLUME: 10500 LITERS
 WEIGHT: C:4500kg, H:1500kg (EX. LID)
 (TANK DIM: ± 20mm. WEIGHT: ± 30kg.)

NOTES:
 THIS DRAWING IN WHOLE OR IN PART SHALL NOT BE COPIED WITHOUT THE PRIOR PERMISSION OF McArdle DOYLE LTD.
 ALL WORKS TO COMPLY WITH THE CURRENT BUILDING REGULATIONS.
 DO NOT SCALE.
 ORDNANCE SURVEY IRELAND LICENCE No. AR 0105722
 © ORDNANCE SURVEY IRELAND / GOVERNMENT OF IRELAND

- NOTES
- 1.) ALL THE TANKS MUST BE PLACED ON A PERFECTLY LEVEL AND FIRM SUITABLE BASE.
 - 2.) AN ANTI-SYPHON VENT IS REQUIRED FOR LONG RUN OUTFLOWS
 - 3.) IT IS ESSENTIAL THAT THIS DRAWING IS READ IN CONJUNCTION WITH RELEVANT DOCUMENT(SUPPLIED WITH UNIT) GIVING INSTALLATION DETAILS AND WITH M&E DOCUMENTATION. THIS DRAWING SHOULD BE USED FOR DIMENSIONAL INFORMATION ONLY.

MAIN CONTRACTOR TO SUPPLY
 ALARM AND COALESCER FILTER

10,000 LITRE CLASS 1 FULL RETENTION SEPARATOR
 TYPE FC-NS-6-CH ORTNER BY MOLLOY PRECAST
 (MOLLOY PRECAST: COLERAINE,
 TULLAMORE, Co. OFFALY, 057 932 6000)

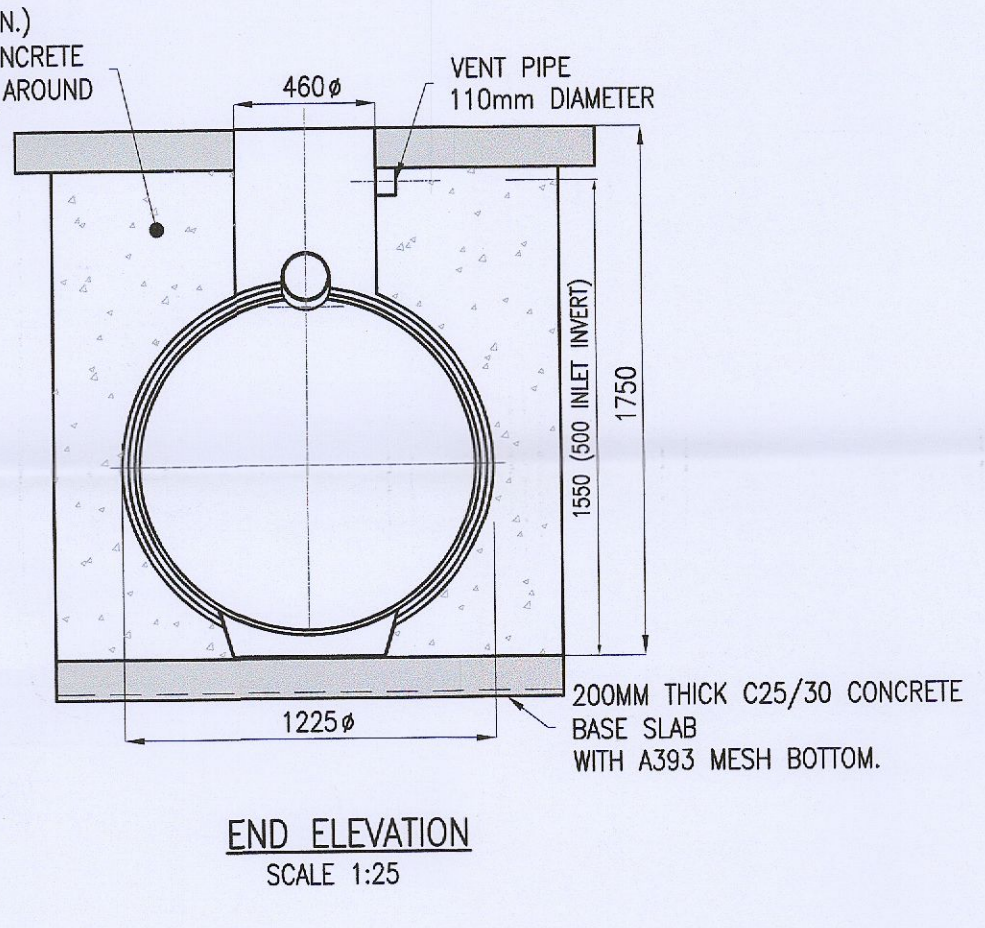
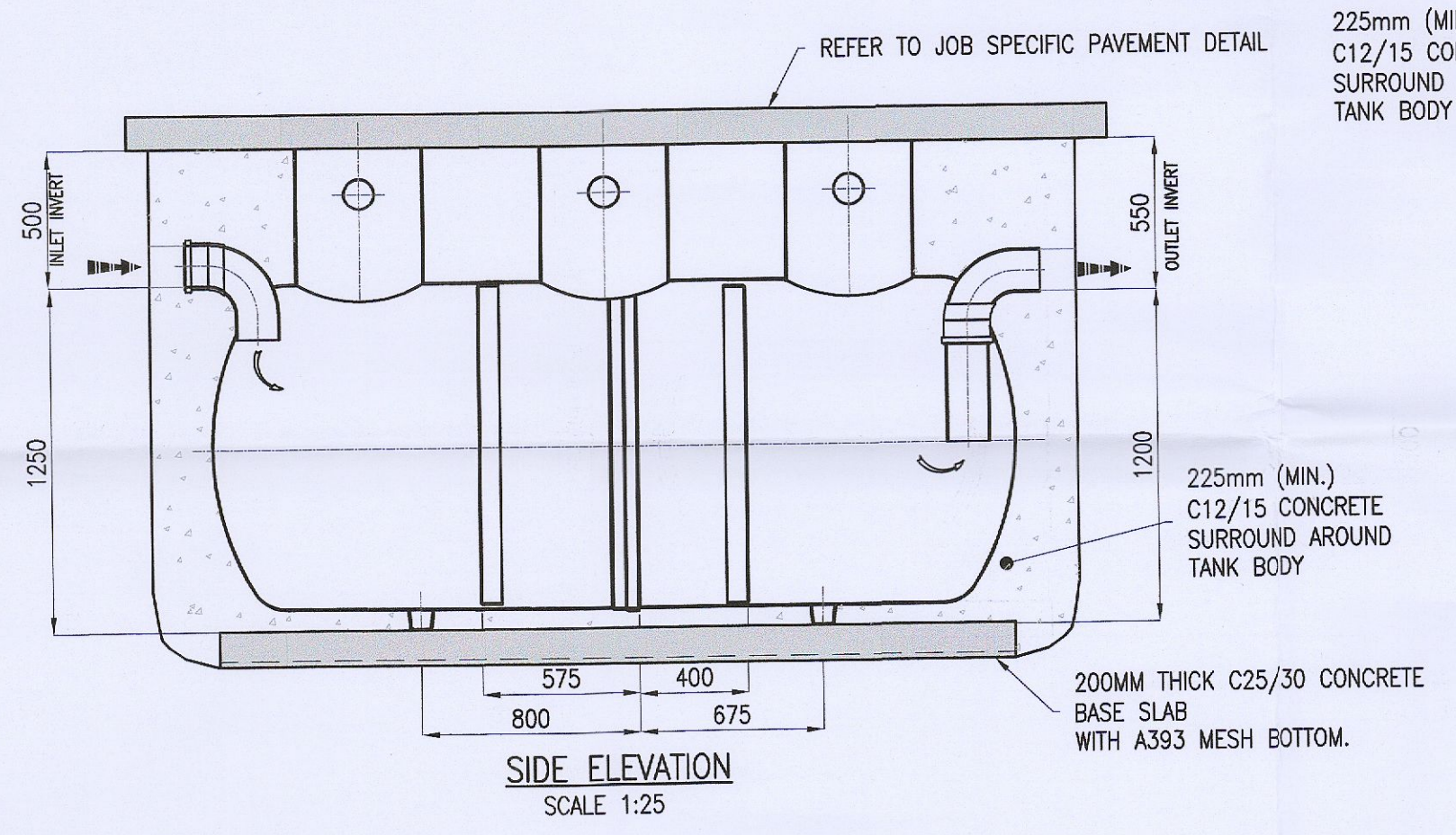
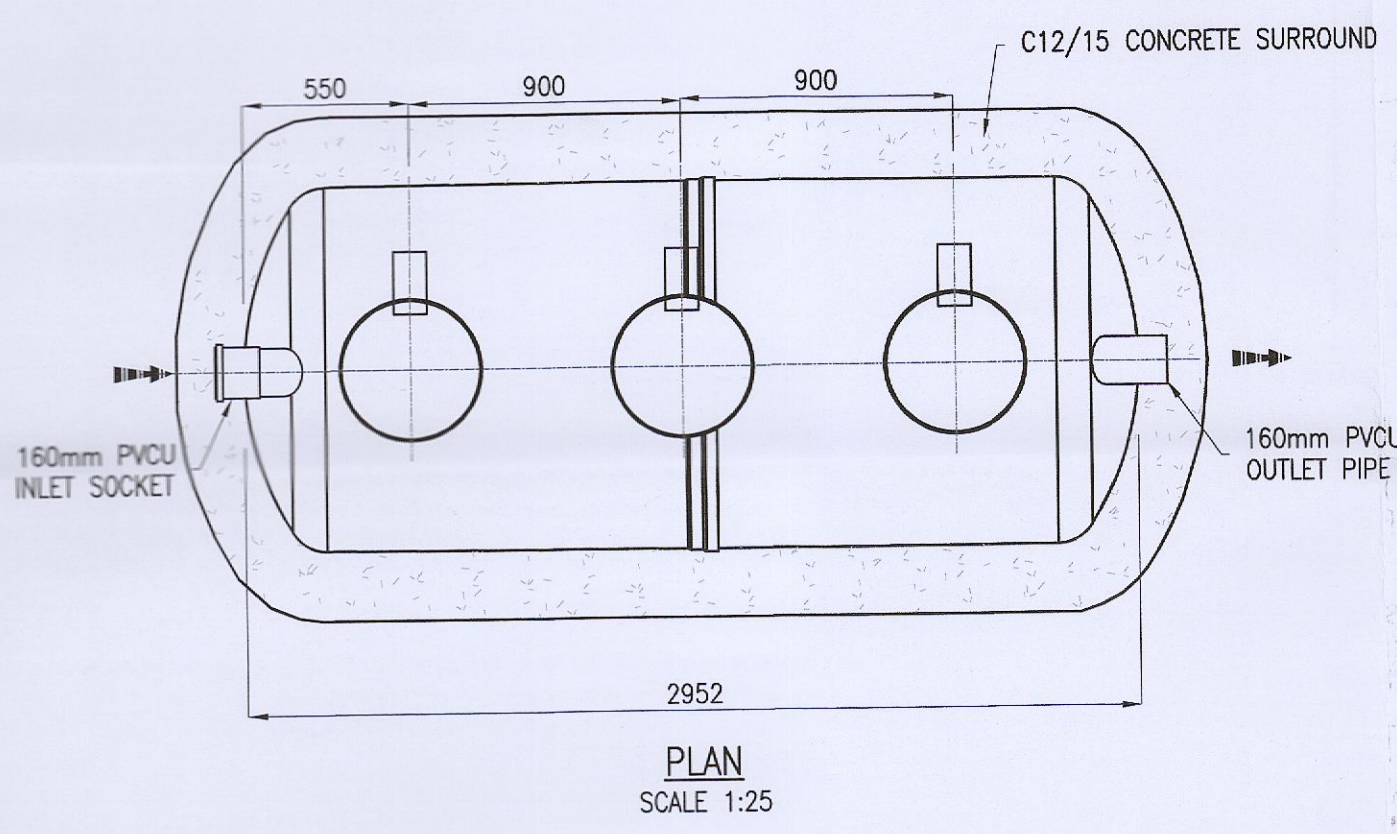

UNIT REF No.	DIM 'A'	DIM 'B'	DIM 'C'	WORKING CAPACITY	APPROX. WEIGHT		FALL ACROSS UNIT
					EMPTY	FULL	
W3/030	2952	500	900	3000L	150 Kg	3200 Kg	50

- NOTES
1. UNITS CAN BE SUPPLIED WITH EXTENSION SHAFTS IN 0.5m INCREMENTS.
 2. STANDARD INLET / OUTLET PIPES ARE PVCu UNDERGROUND DRAINAGE TO BS4660. FOR OTHER PIPE SIZES AND TYPES AVAILABLE CONSULT KLARGESTER.
 3. IT IS ESSENTIAL THAT THIS DRAWING IS READ INCONJUNCTION WITH THE INSTALLATION INSTRUCTIONS (SUPPLIED WITH UNIT). THIS DRAWING SHOULD BE USED FOR DIMENSIONAL INFORMATION ONLY.

MAIN CONTRACTOR TO SUPPLY
 AND INSTALL ALL SEPARATORS

CARWASH SEPARATOR DETAILS
 KINGSPAN W3/030

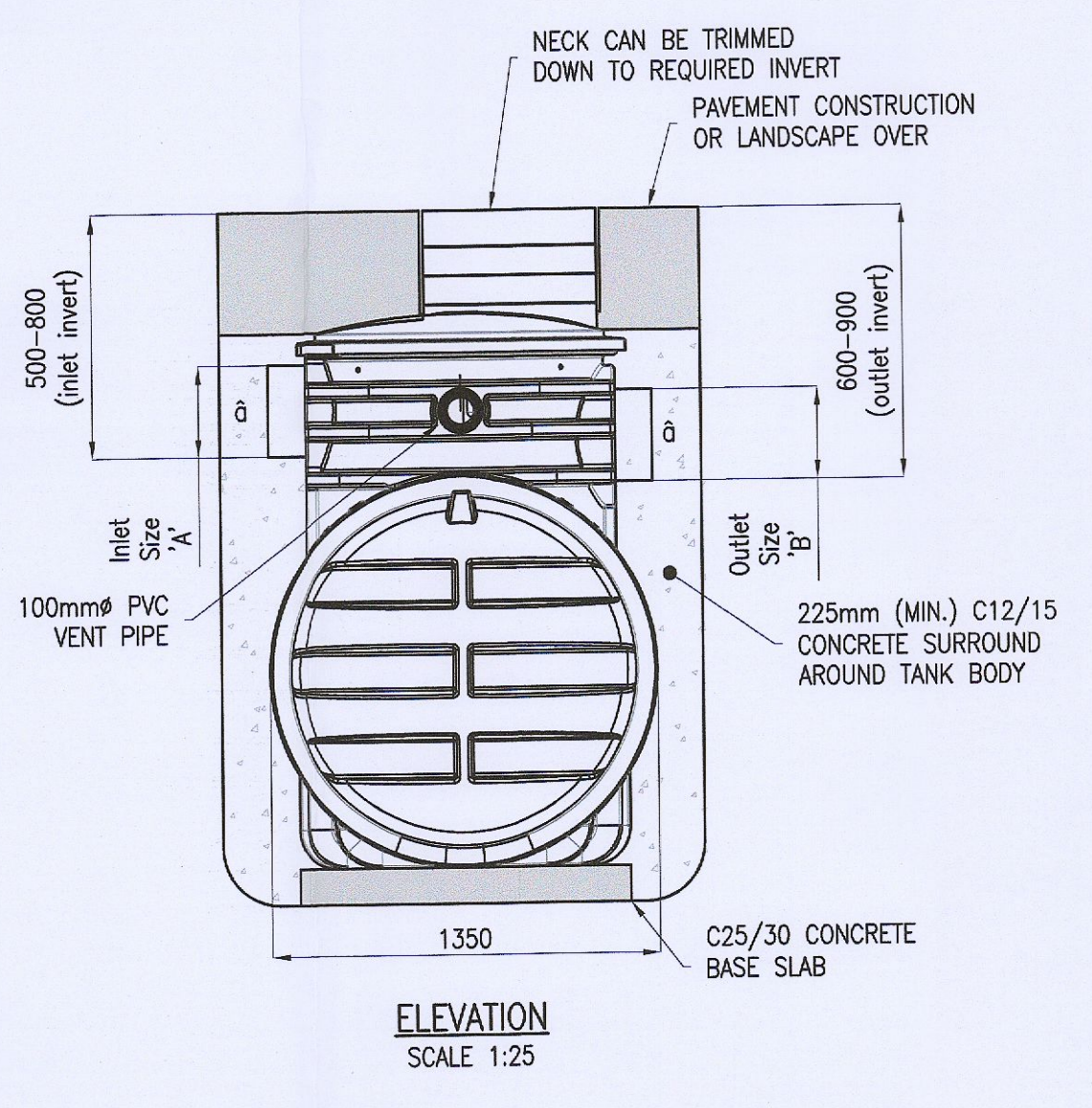
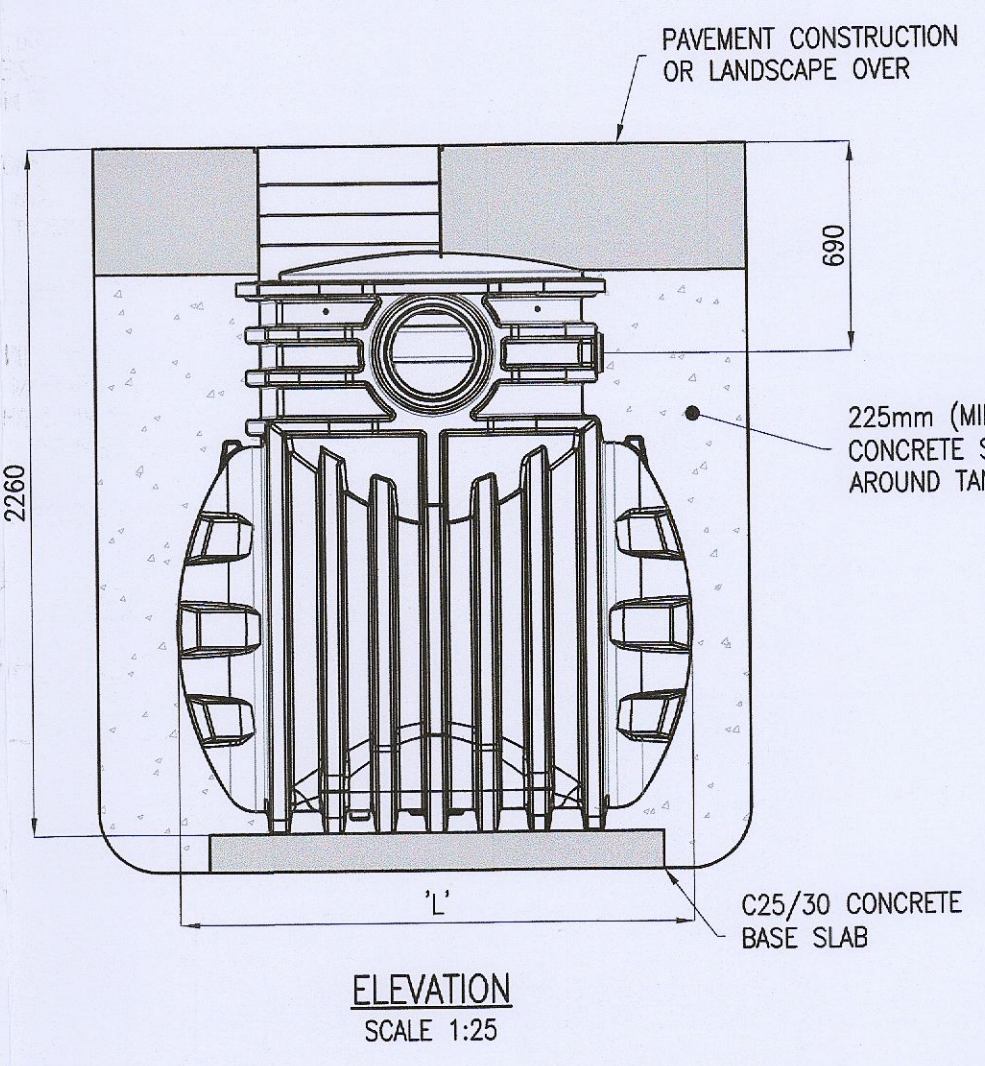
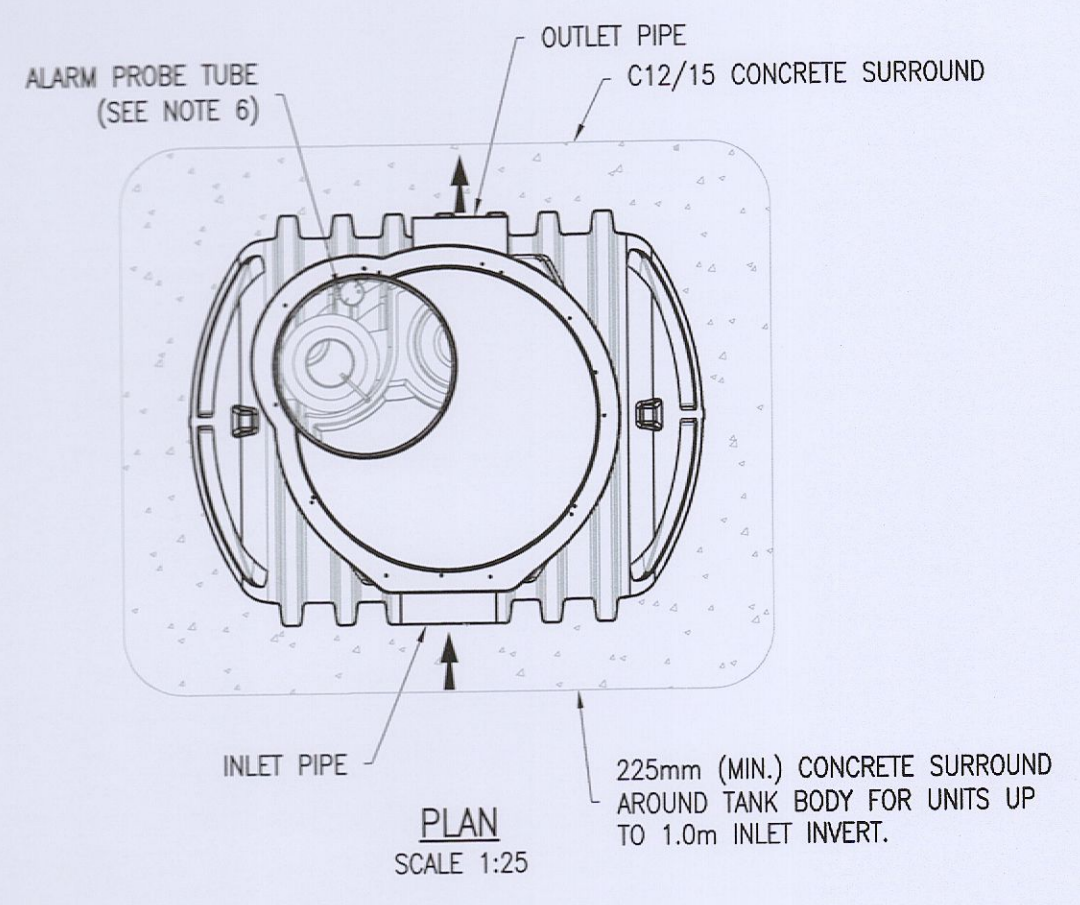

- NOTES
1. INLET/OUTLET PIPES ARE PLAIN PIPE Ø315 MM PVCu. THE STANDARD EN 858 STATES MINIMUM CONNECTION SIZES, UNITS ORDERED WITH DIFFERENT SIZED CONNECTIONS ARE NOT FULLY COMPLIANT WITH THE STANDARD.
 2. EXTENSION NECKS FOR DEEPER INVERTS CAN BE PROVIDED. THESE CAN BE CUT IN 200mm SECTIONS. MAX 2.0m INVERT RECOMMENDED. PLEASE ASK OUR SALES DEPARTMENT FOR FURTHER DETAILS.
 3. ALL UNITS REQUIRE APPROPRIATE COVER AND FRAME TO SUIT APPLIED LOADINGS.
 4. THIS DRAWING SHOULD BE USED FOR DIMENSIONAL INFORMATION ONLY. IT IS ESSENTIAL THAT THIS DRAWING IS READ IN CONJUNCTION WITH THE INSTALLATION GUIDELINES SUPPLIED WITH THE UNIT.
 5. THIS DRAWING IS ALSO AVAILABLE ON OUR WEBSITE WWW.KINGSPANENV.COM.
 6. A Ø76mm TUBE (INTERNAL) IS SUPPLIED TO HOUSE AN OIL ALARM PROBE.
 7. WET SITE CONDITIONS - CONCRETE BACKFILL
 DRY SITE CONDITIONS - PEA SHINGLE BACKFILL
- PLEASE REFER TO INSTALLATION MANUAL FOR DETAILS OF CORRECT BACKFILLING.

DIMENSIONS

UNIT REF No.	PEAK FLOW	DIM 'L'	STD. PIPE Ø	FALL ACROSS UNIT
NSBP003	30 L/S	1700	160	100

MAIN CONTRACTOR TO SUPPLY
 AND INSTALL ALL SEPARATORS

CLASS 2 BY-PASS SEPARATOR DETAILS

Rev.	Description	By	Date
-	ISSUED FOR PLANNING	GDR	09.09.22

McArdle Doyle
 Second Floor Exchange Building The Long Walk Dundalk, Co. Louth
 Chartered Engineers Architectural Services & Project Managers
 mail@mcardle-doyle.ie +353(0) 42 942 9052

PROJECT:
 UNMANNED SERVICE STATION, LIFFEY VALLEY

CLIENT:

DRAWING TITLE:
 PROPOSED PETROL SEPARATORS

Date 09/09/22	Drawn GDR	Checked RMA	Approved RMA
Scale at A1 1:25	Drawing Number P1956.C10	Status PL	Rev. -