

DO NOT SCALE DRAWING

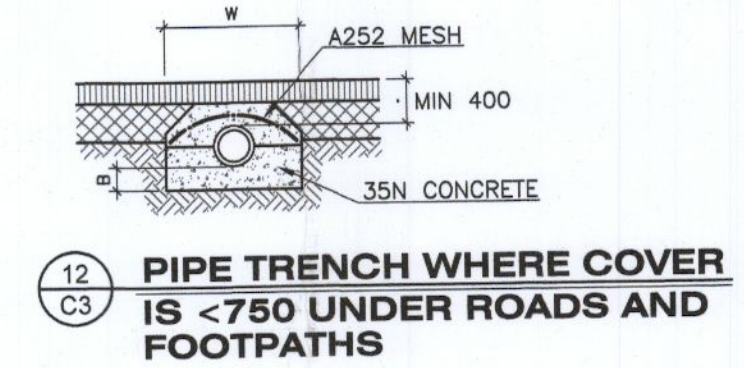

TRENCH WIDTHS AND DIMENSIONS FOR FOUL AND SURFACE WATER DRAINS

PIPE DIA mm	Do OUTSIDE COLLAR	B	T	TRENCH W WIDTH	MANHOLE TYPE	MIN FALL
110	150	150	150	750	PIPE LIMITED IN PUBLIC AREAS OR PUBLIC PLACES	1:40
160	210	150	150	800		1:150
200	250	150	150	900		1:150
225	275	150	150	900		1:150
250	300	150	150	900		1:150
315	365	150	150	900		1:150
325	375	150	150	900		1:150

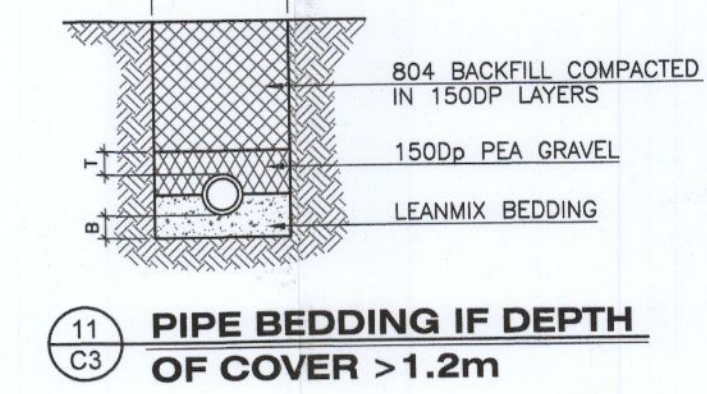
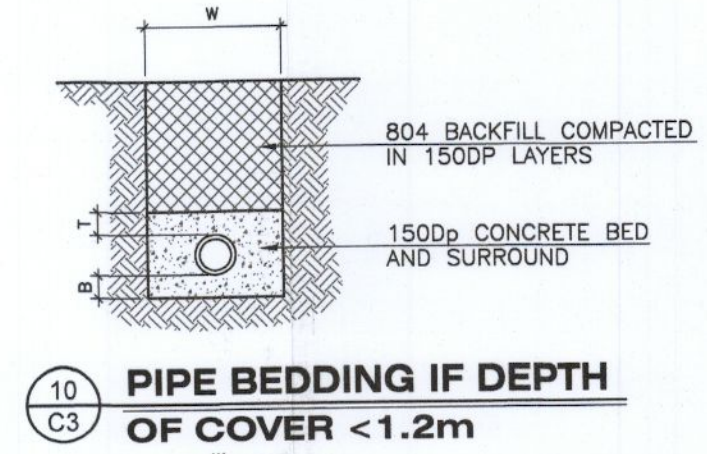
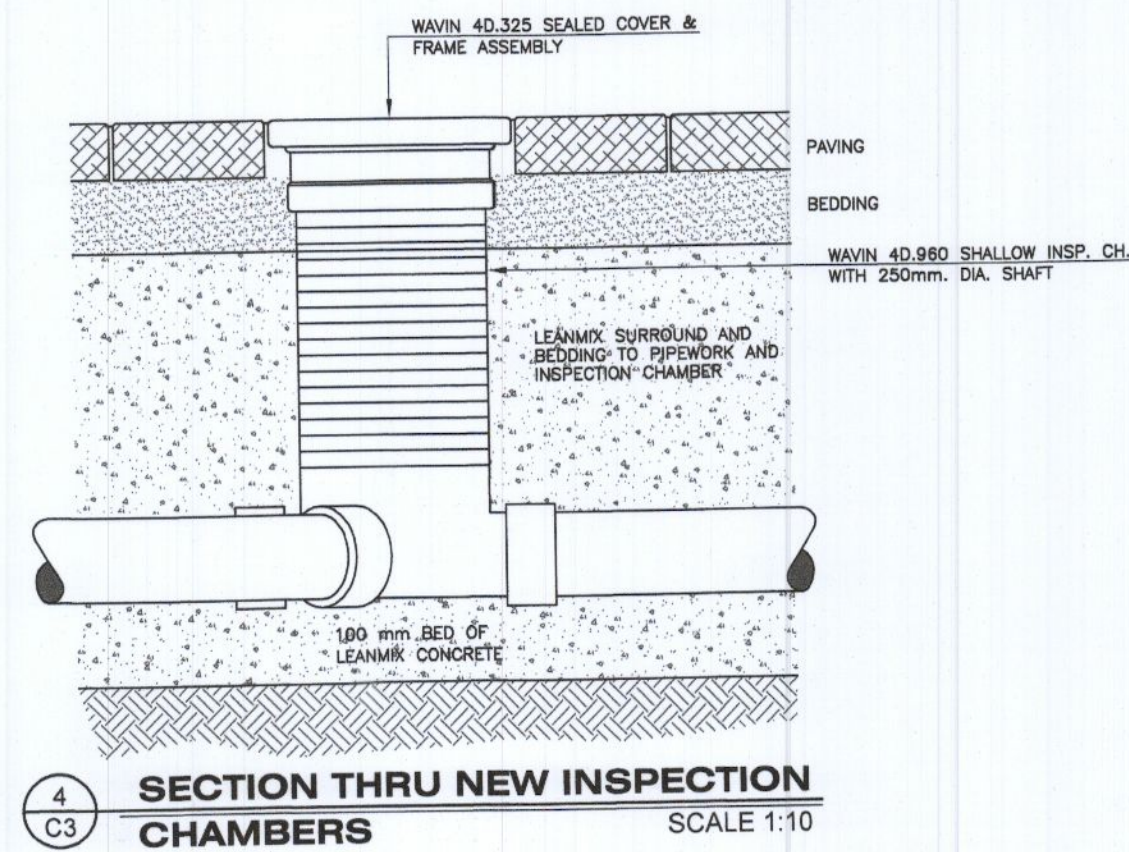
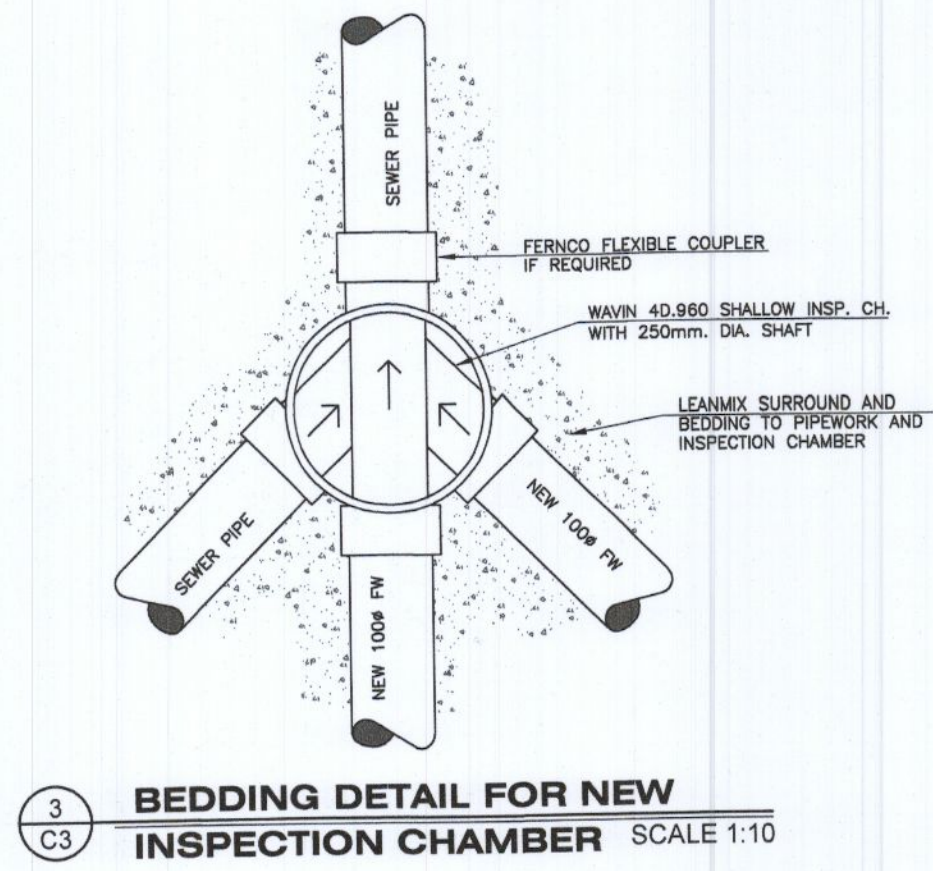
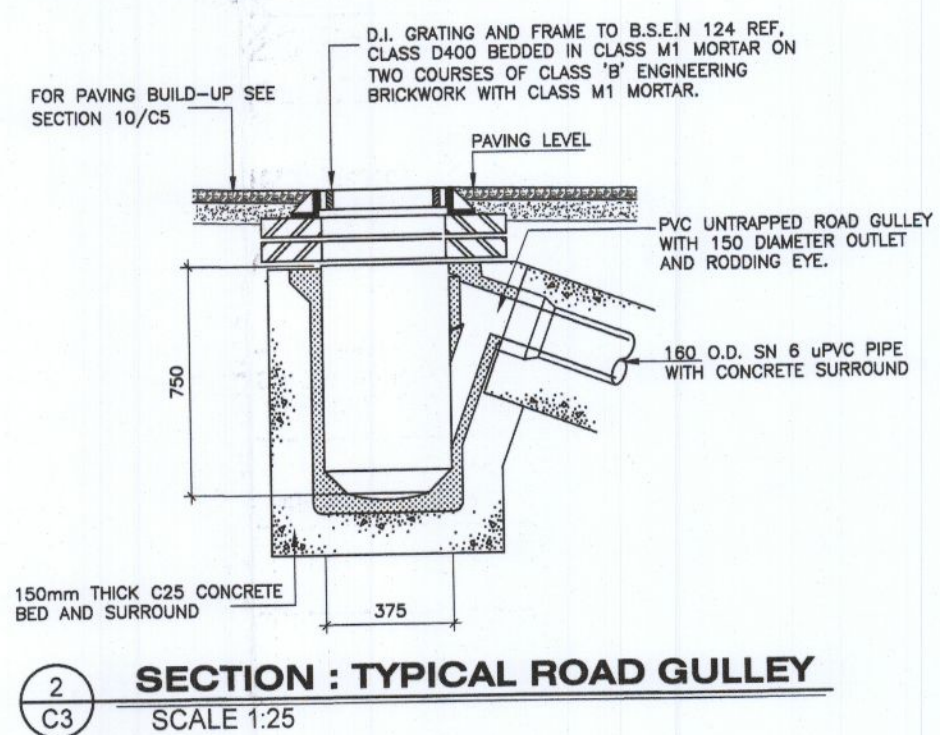
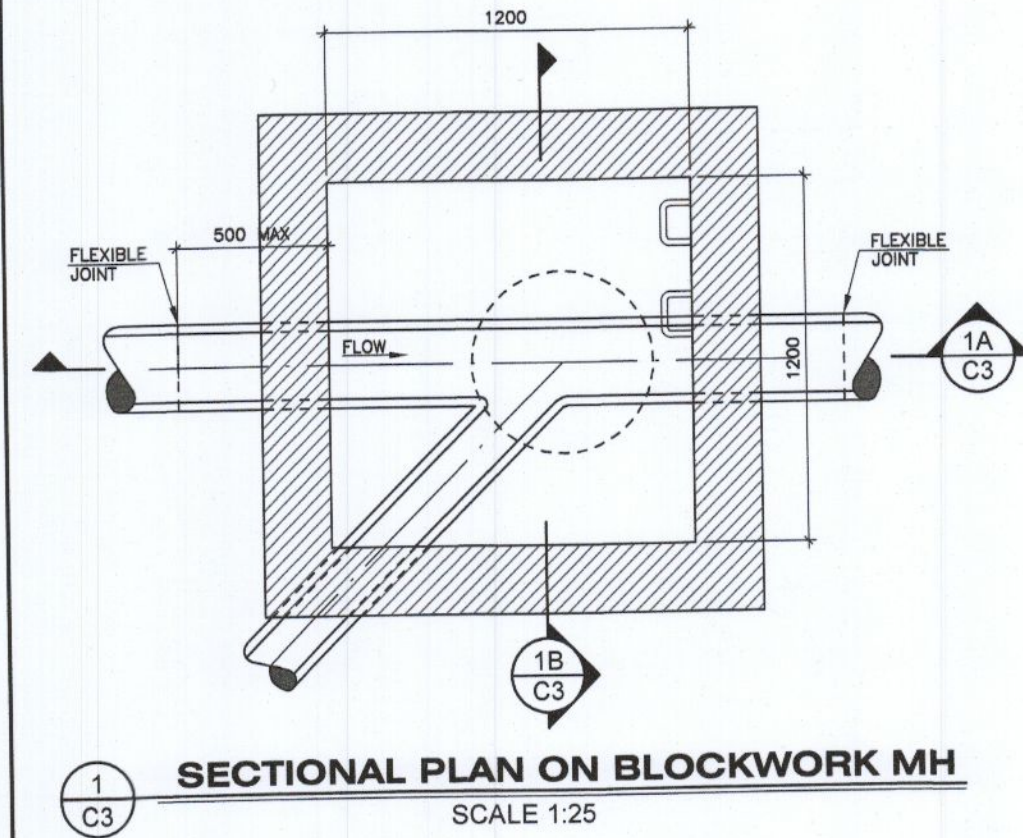
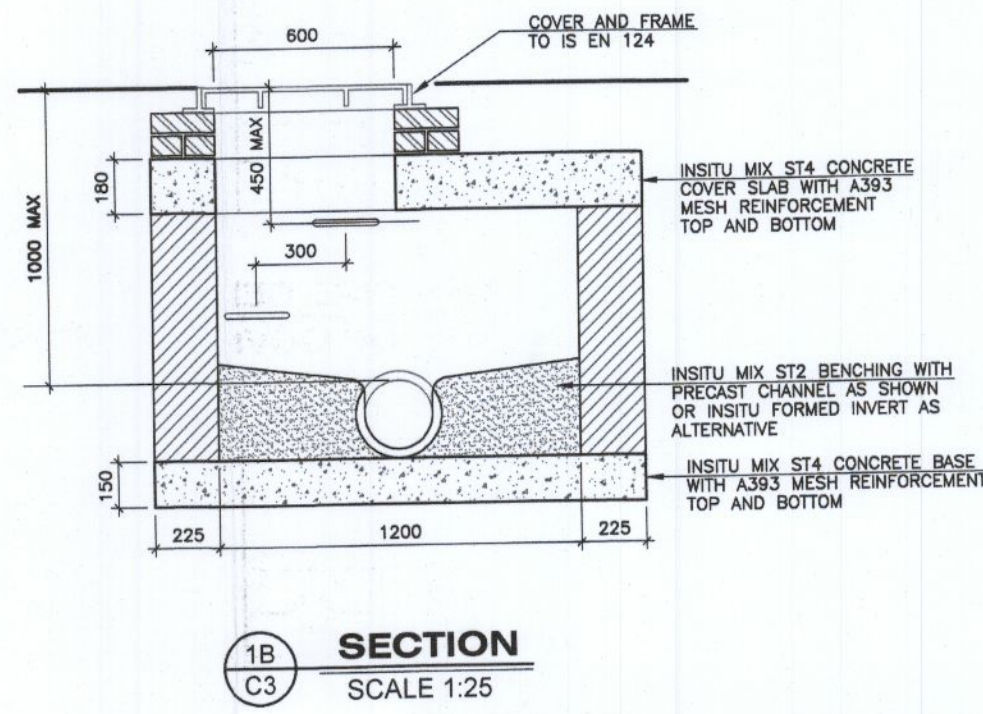
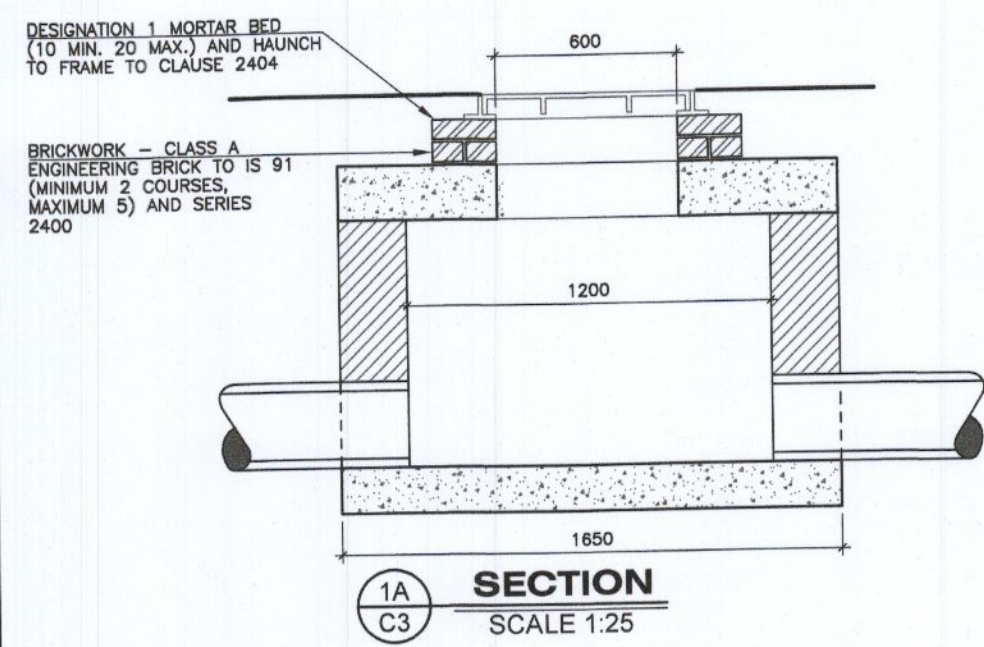
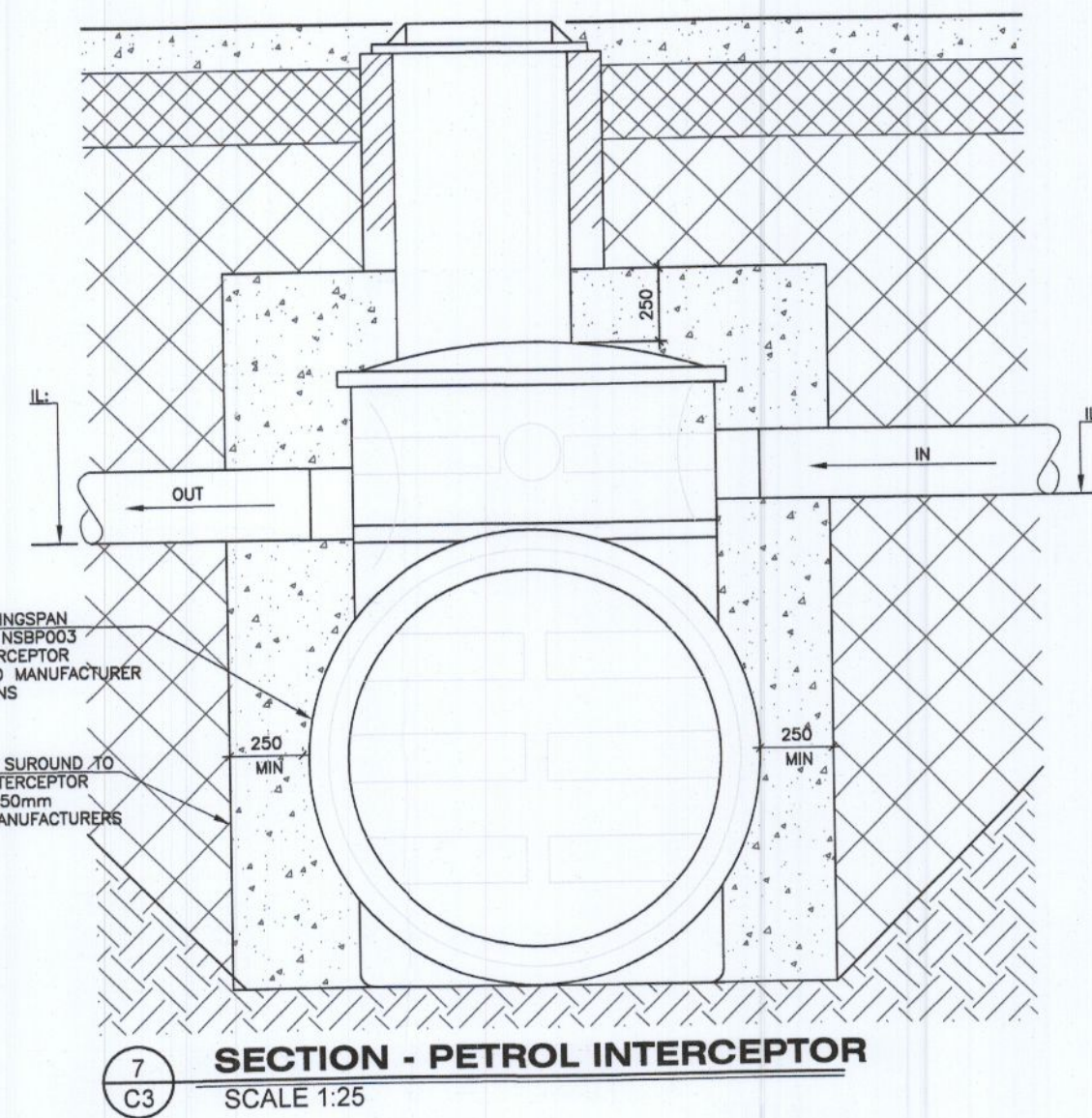
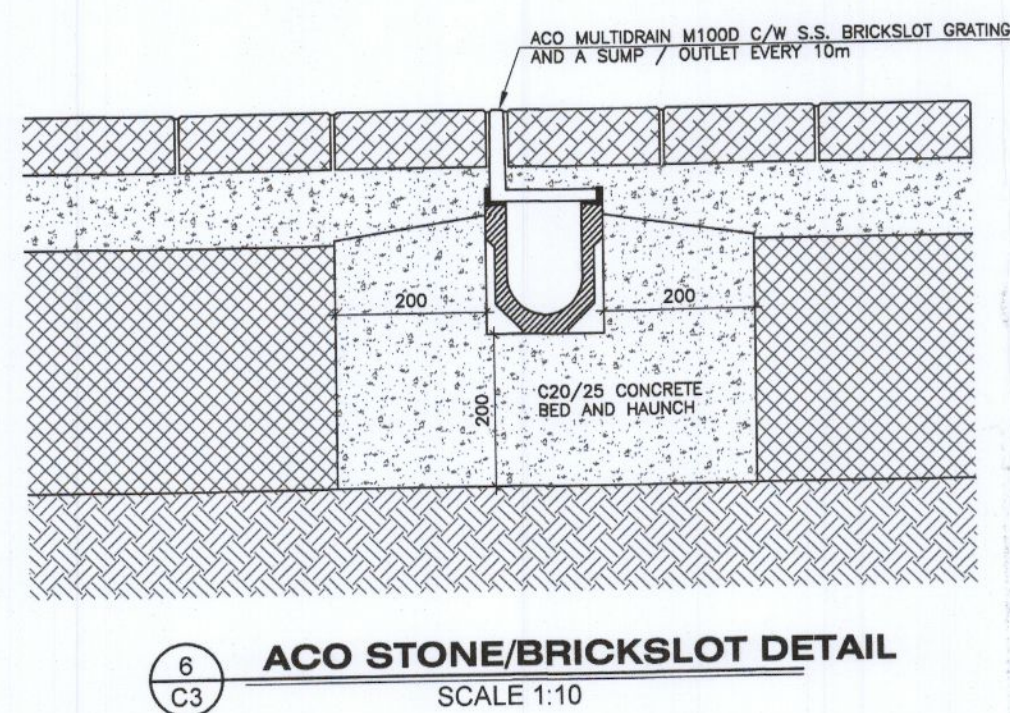
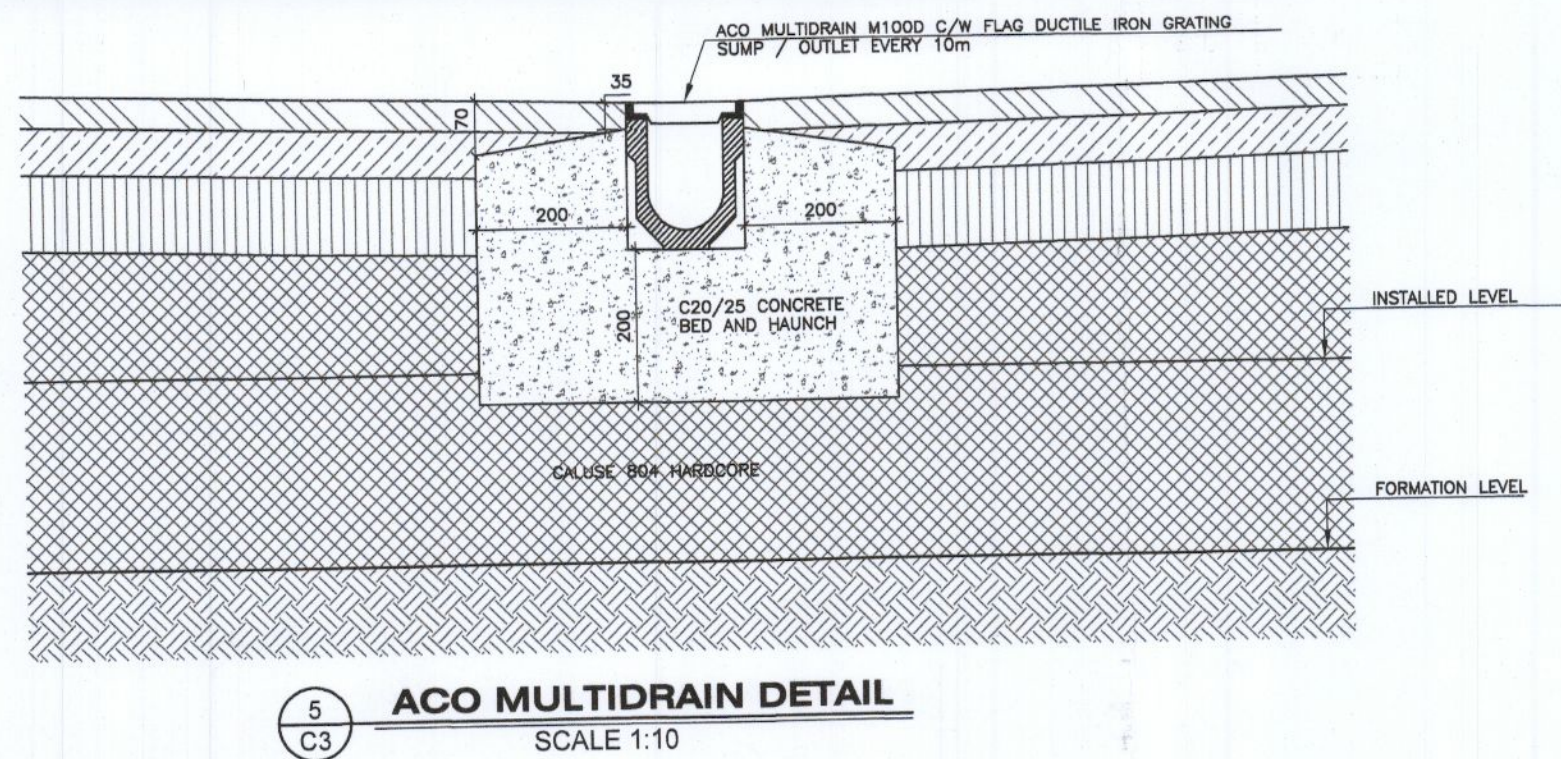

A	ISSUED FOR PLANNING	05.10.22
Rev	Revision details	Date

**JJ CAMPBELL & ASSOCIATES**  
CONSULTING CIVIL & STRUCTURAL ENGINEERS  
F1 Nutgrove Office Park, Dublin 14  
tel. 01 2980538, e-mail info@jjc.ie, www.jjc.ie

**IONet** MEMBER OF ACEI  
INTERNATIONAL CERTIFICATION NETWORK

QUALITY REGISTERED NSAI Certified

Client  
**Jogor Point Ltd**

Architect  
**CATHAL O'NEILL ARCHITECTS**

Project Name  
**BALLYDOWD WAREHOUSE**

Drawing Title  
**DRAINAGE : DETAILS / SECTIONS SHEET 1**

Original Drawing Size : A1  
Scale : N/A Copyright © JJ Campbell & Assoc

Project No.  
**2211-04** Drawing No.  
**C3**