

SECTION VIEW SHOWING PROPOSED EXTENSION

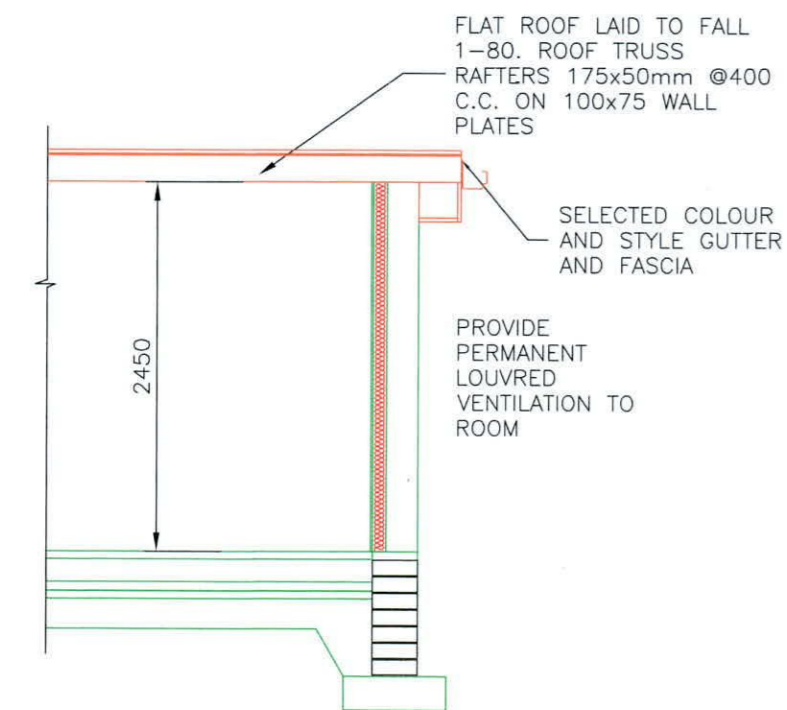

SECTION VIEW SHOWING PROPOSED EXTENSION

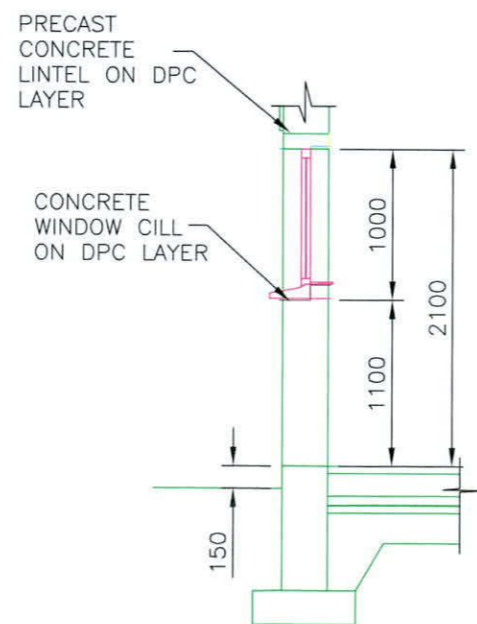

TYPICAL WINDOW DETAIL

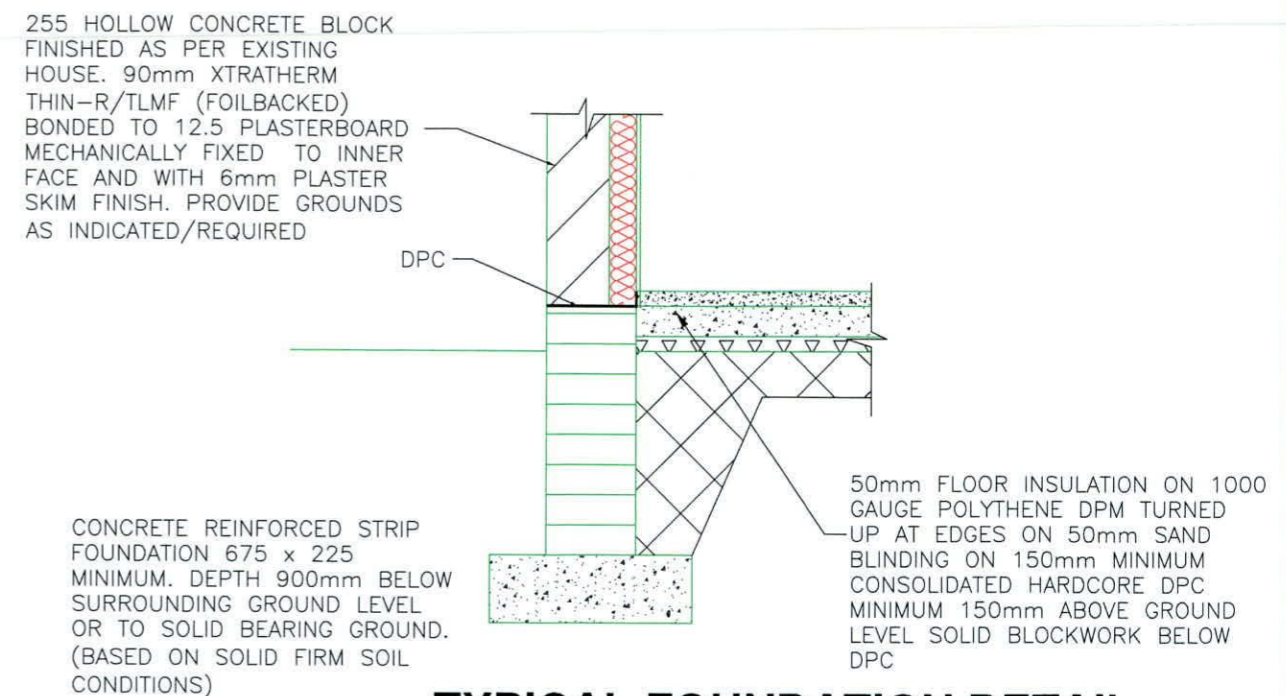

TYPICAL FOUNDATION DETAIL

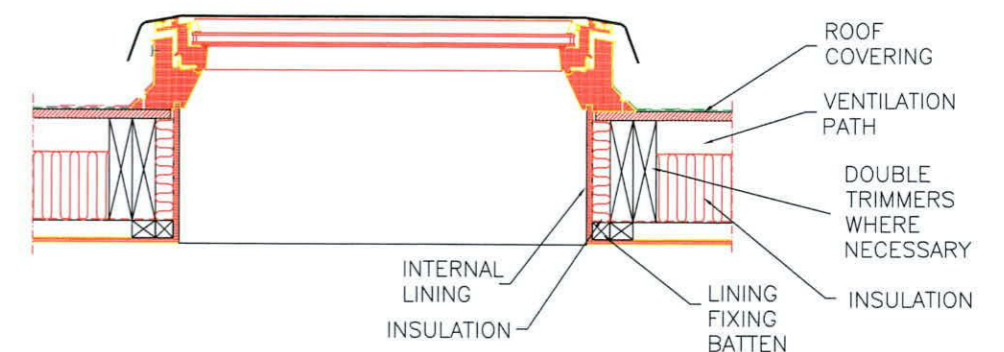

TYPICAL ROOF WINDOW DETAIL

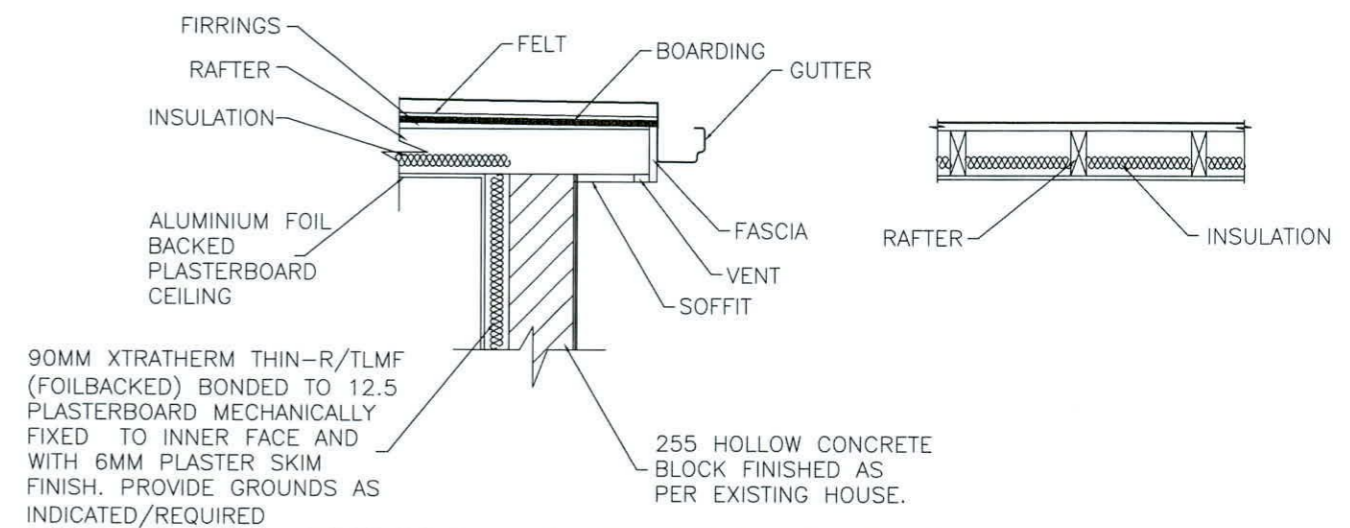

TYPICAL FLAT ROOF DETAIL



The information contained in this drawing is confidential and must not be divulged to any third party without the written consent of 4bes Design Services.



38 Larkfield Avenue
Lucan
Co. Dublin

17 Fforster Green
Ballydowd Manor
Lucan, Co. Dublin
K78 KX05

PROPOSED SECTION AND DETAILS

DRAWN	JOHN FORBES , 38 LARKFIELD AVE. , LUCAN, Co. DUBLIN	
DATE	Sept 2022	Teddy and Zoe O'Connor
SCALE	1:50 @ A3	

FG - 11