

IMPORTED GRANULAR MATERIALS TO INCLUDE AGGREGATES TO BS 102, AIR-COOLED BLAST FURNACE SLAG TO BS 1047 & SINTERED PULVERIZED FUEL ASH TO BS 3379.

PIPE DIAMETER	CLASS OF BEDDING	IMPORTED GRANULAR MATERIAL (NOTE 1)
100	S B	10mm nominal size
OVER 100 to 150	S B	10 or 14mm nom. single size or 14 to 5mm graded
OVER 150 to 225	S B	10, 14, 20mm nom. single size or 14 to 5mm graded or 20 to 5mm graded
OVER 225 to 300	S B	10, 14, 20mm nom. single size crushed rock or 14 to 5mm graded or 20 to 5mm graded or 40 to 5mm graded
OVER 300 to 350	S B	
OVER 350 to 400	S B	
OVER 400 to 450	S B	

ANGULAR MATERIALS SHOULD BE CHOSEN TO ENSURE SUFFICIENT SUPPORT IS PROVIDED TO HEAVIER PIPES. CLASS B BEDDING SHALL BE USED WITH FLEXIBLE PIPES.

BY INSERTING COMPRESSIBLE BOARD AT INTERVALS NOT EXCEEDING 500mm, PRECUT TO DIAMETER, HEIGHT AND WIDTH EQUAL TO THE CONCRETE CROSS SECTION. REFER TO DIMENSIONS FOR PIPE BEDDING TABLES FOR THICKNESS OF FILLER.

FOR VALUES OF Y REFER TO DIMENSIONS FOR PIPE BEDDING TABLES

PIPE DIAMETER	Y minimum		MAXIMUM TRENCH WIDTH	L
	Y1 min.	Y2 min.		
100	100	200	700	18
150	100	200	750	18
200	100	200	800	18
225	100	200	825	18
250	100	200	850	18
300	100	200	925	18
350	100	200	1000	18
375	100	200	1090	18
400	150	200	1025	18
450	150	200	1175	36

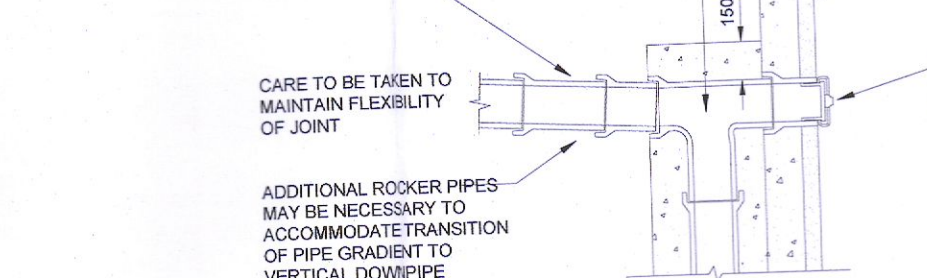
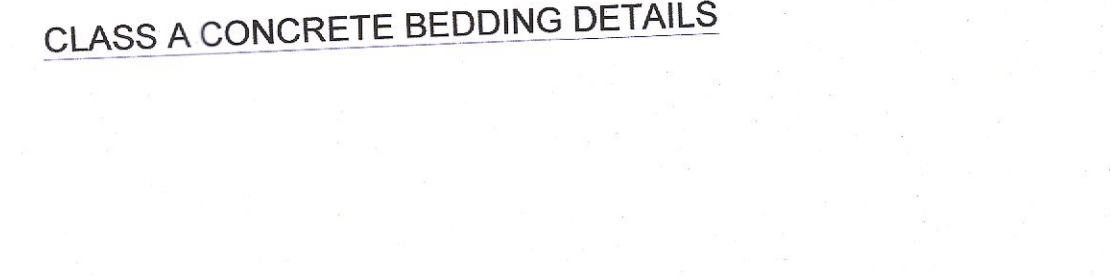
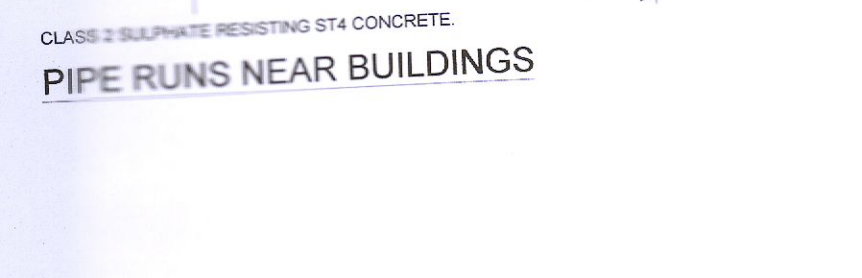

GRANULAR BEDDING & SIDEFILL MATERIALS FOR RIGID + FLEXIBLE PIPES

DIMENSIONS FOR PIPE BEDDING

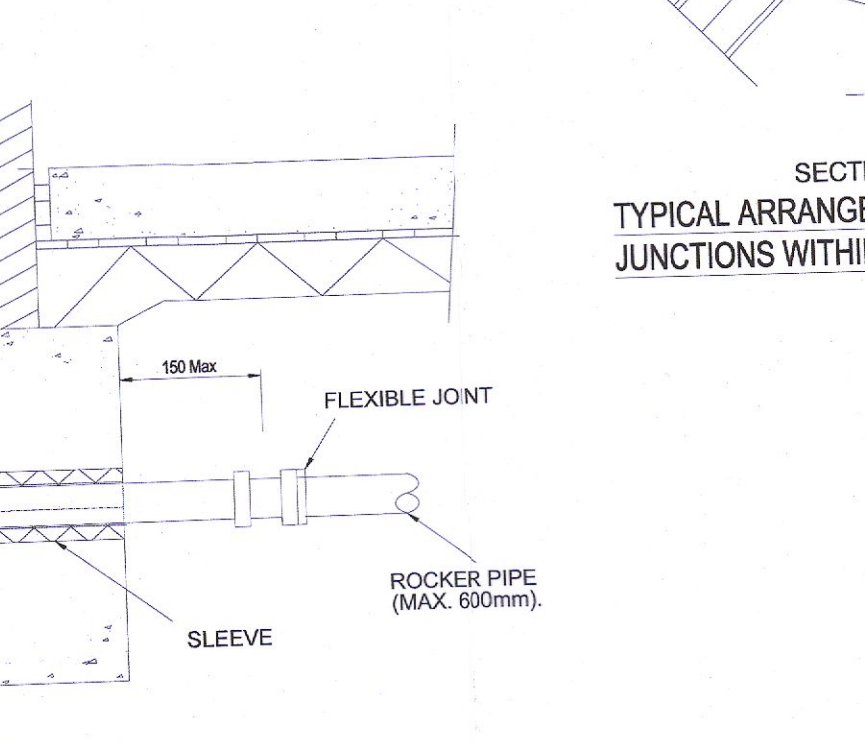
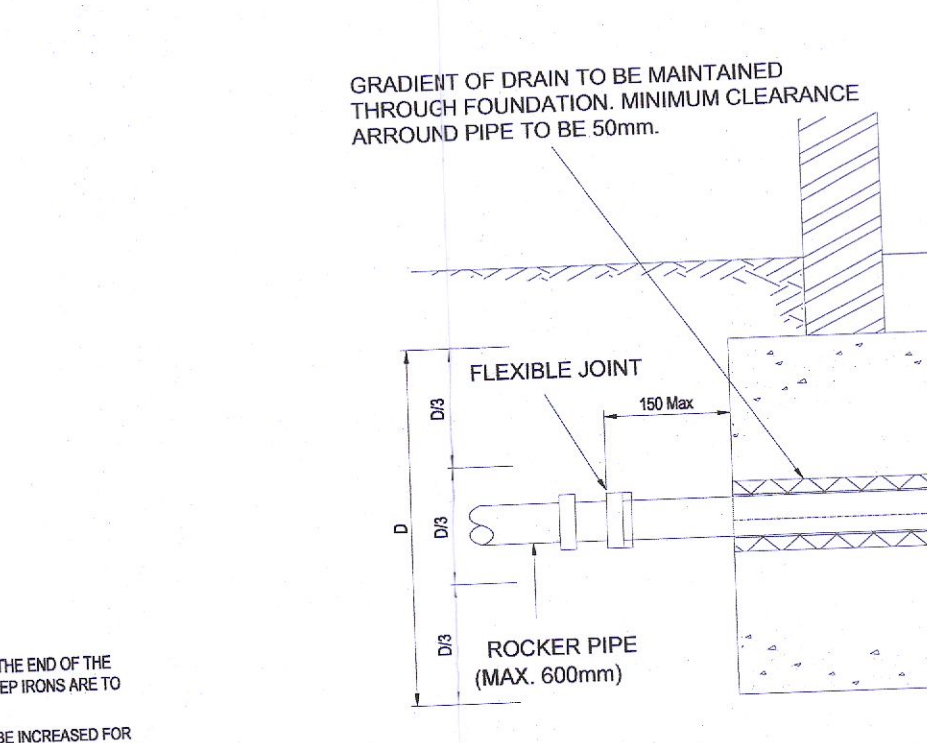
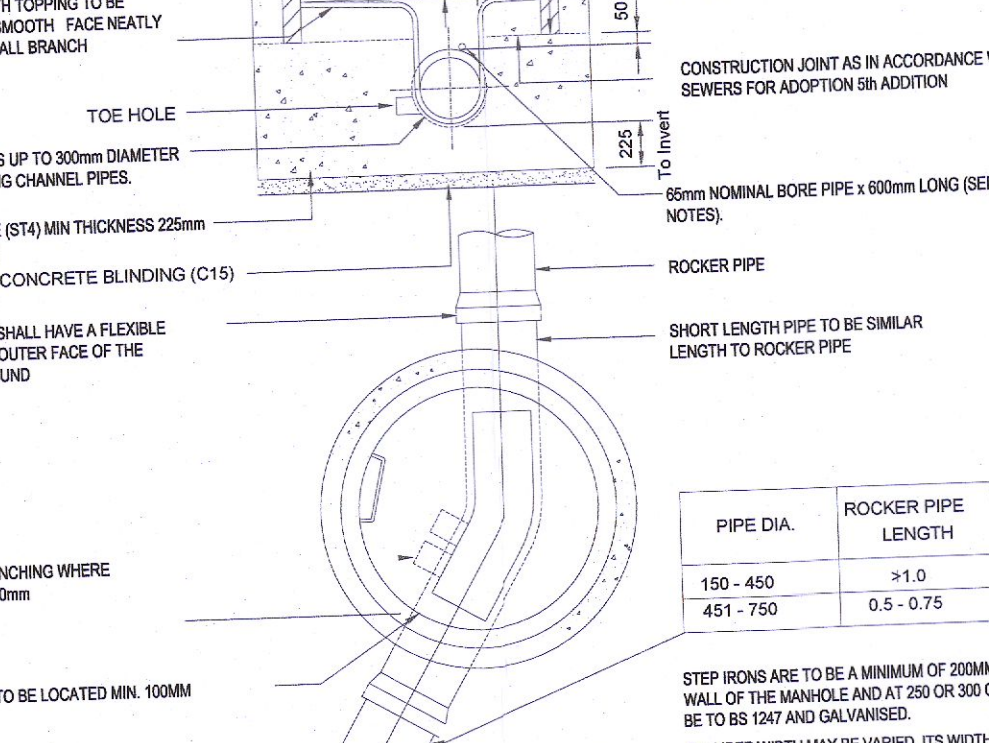
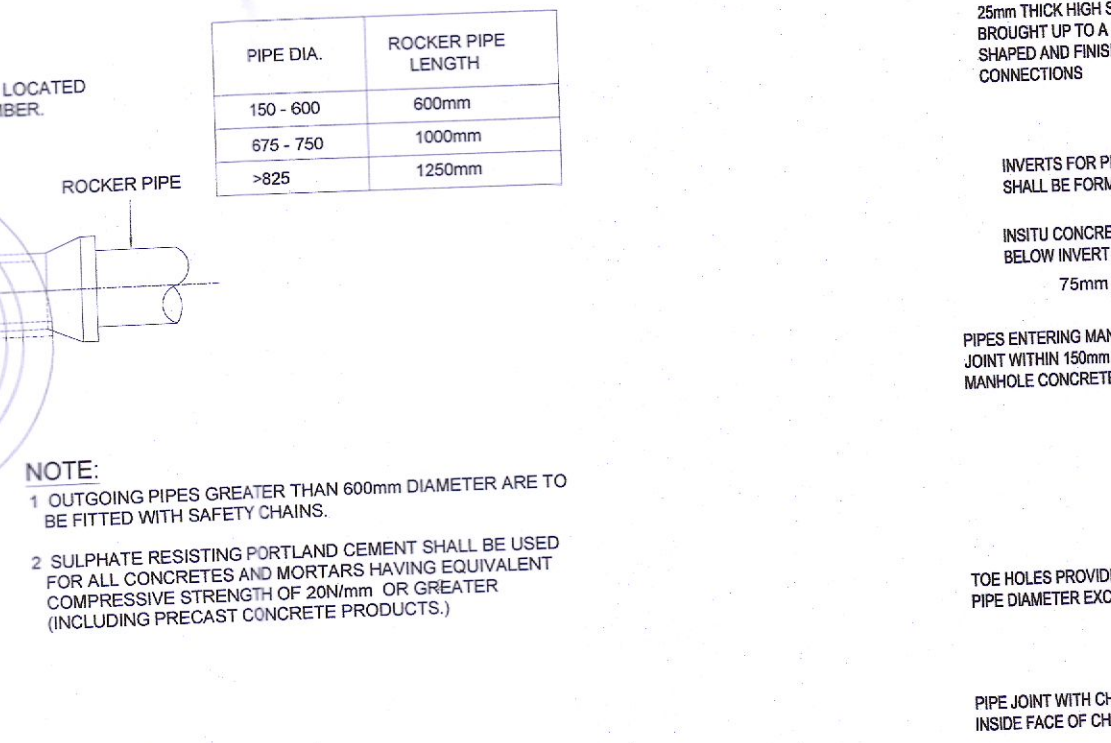
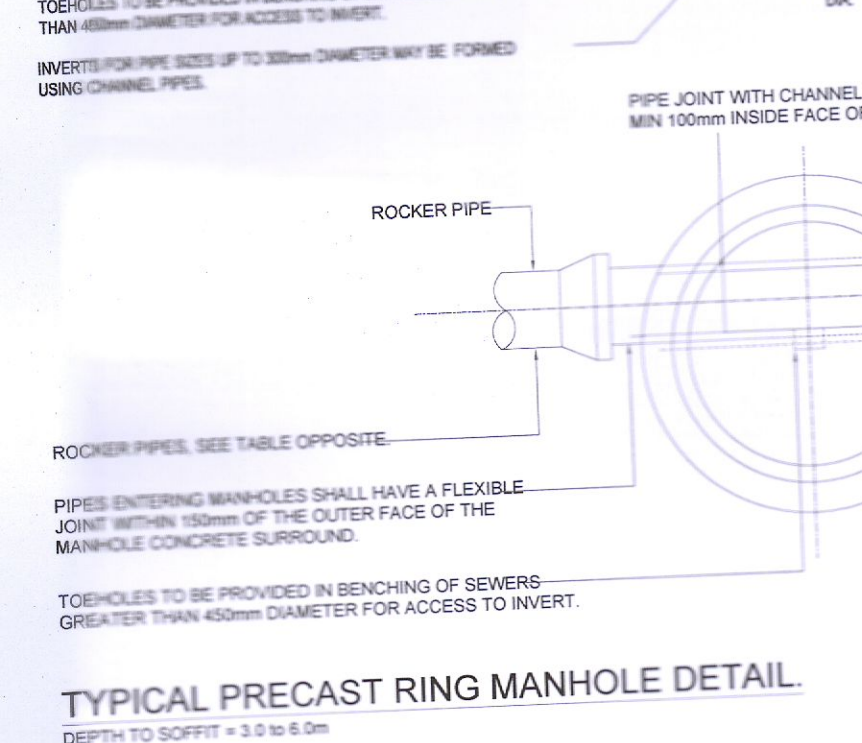
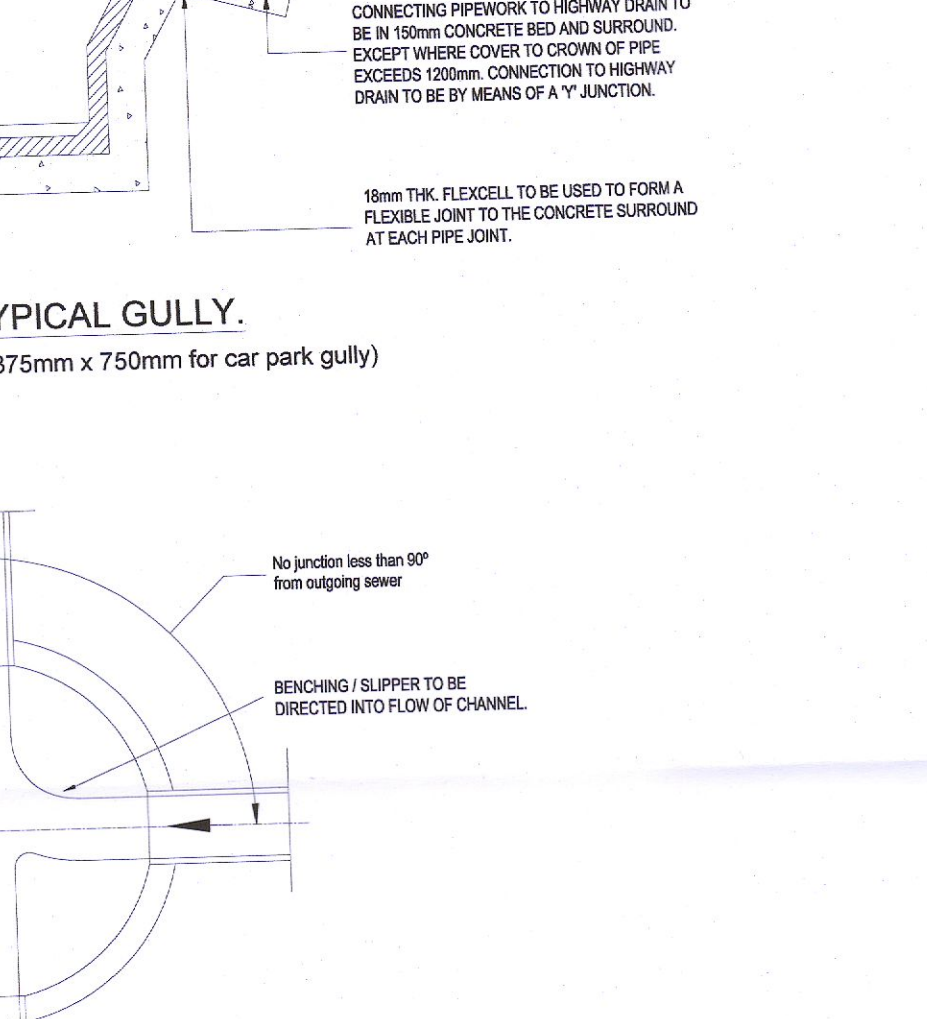
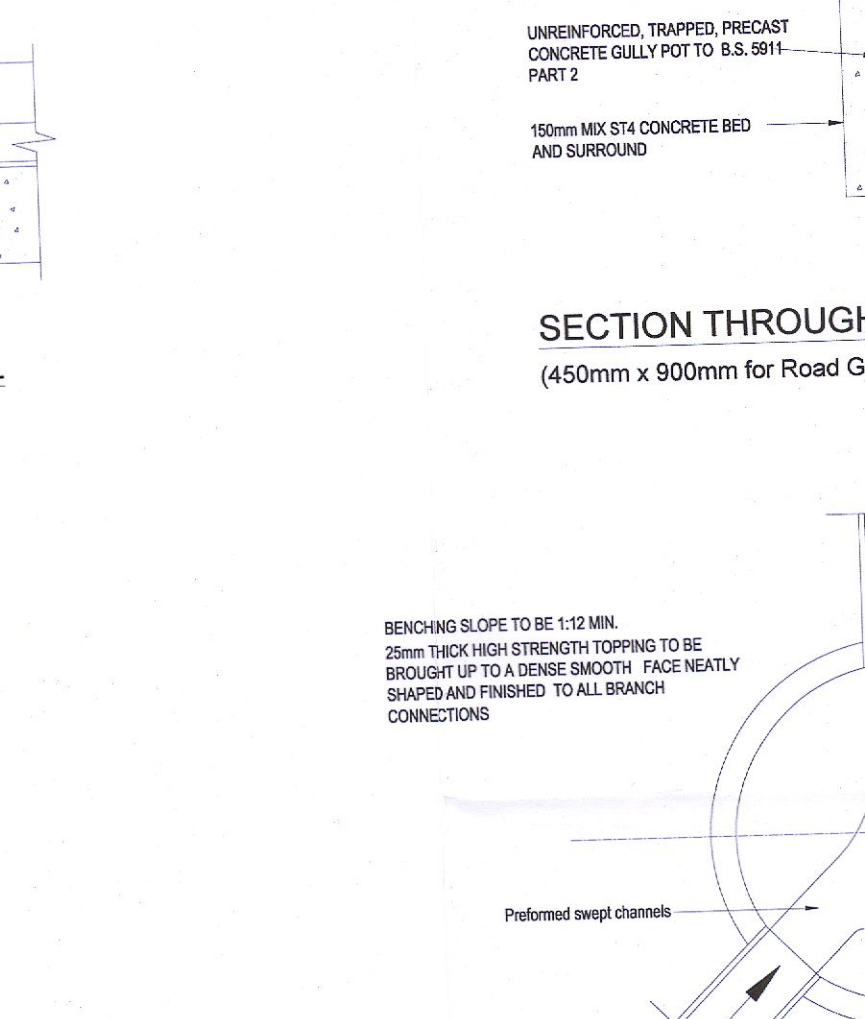
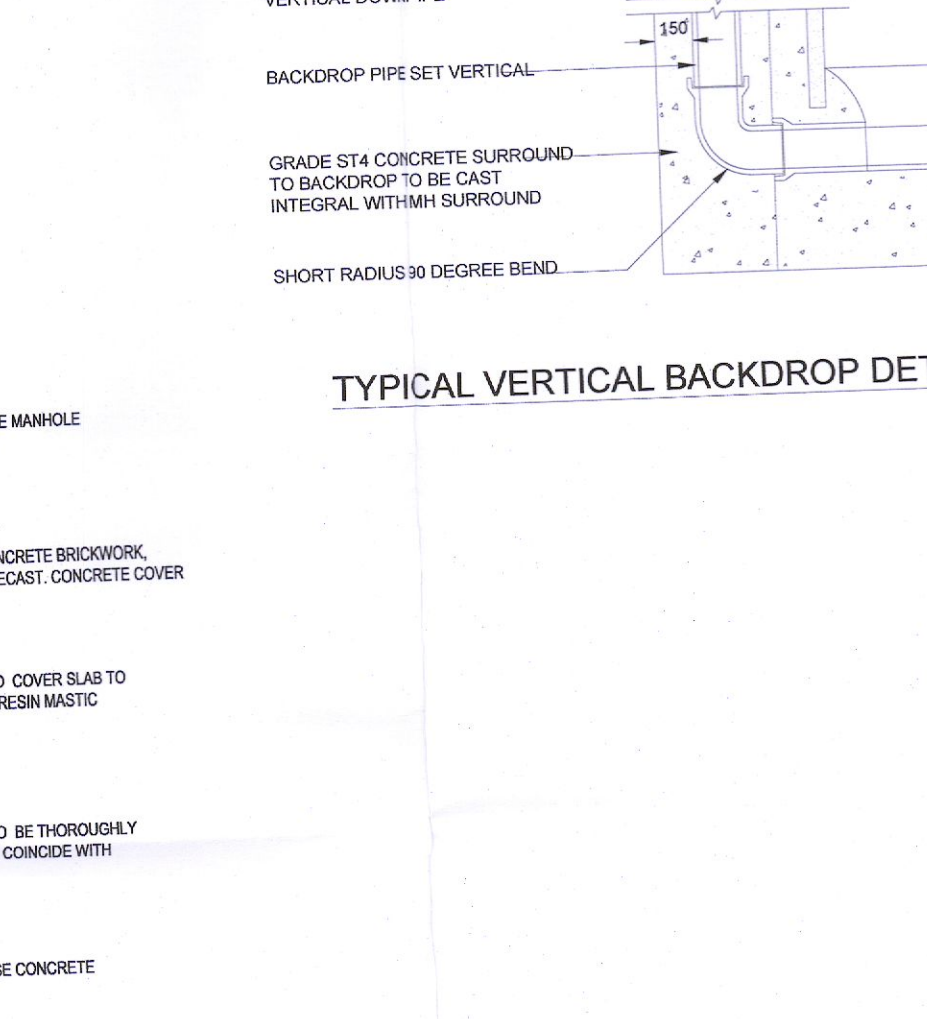
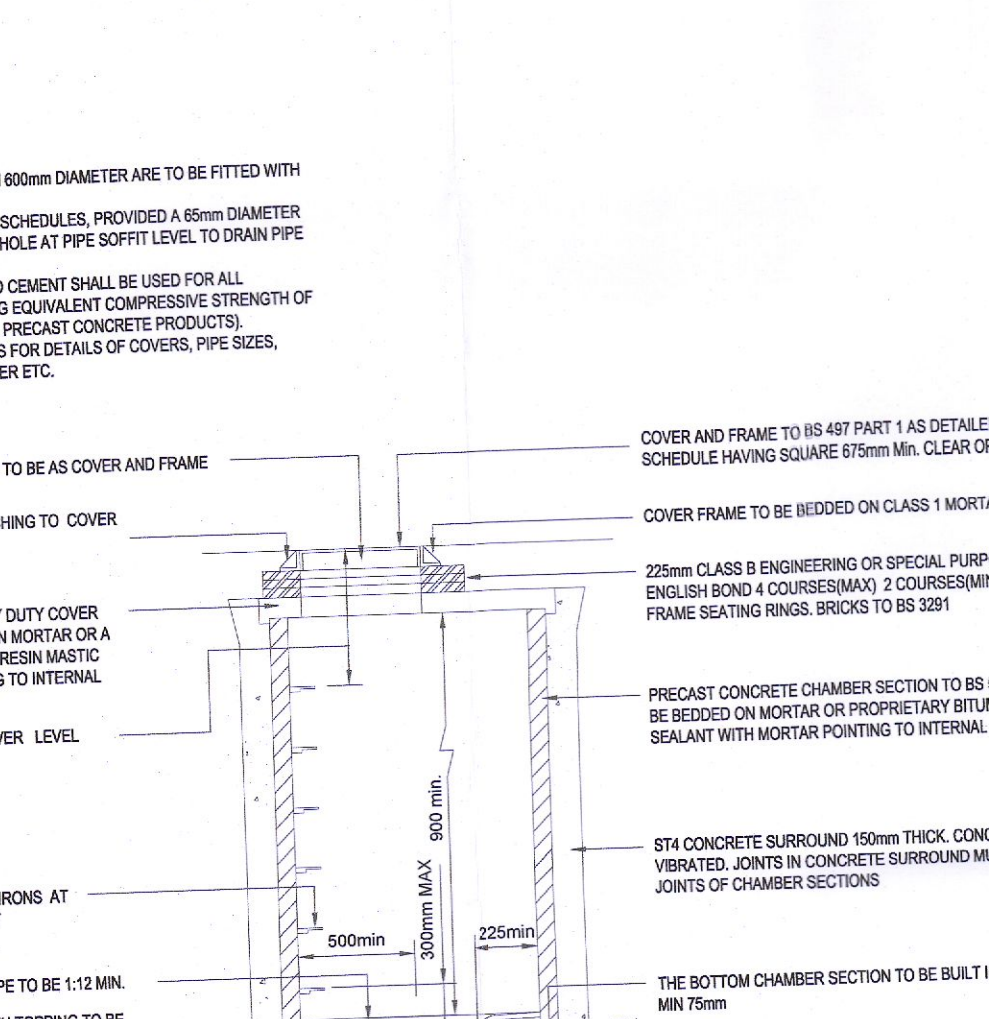
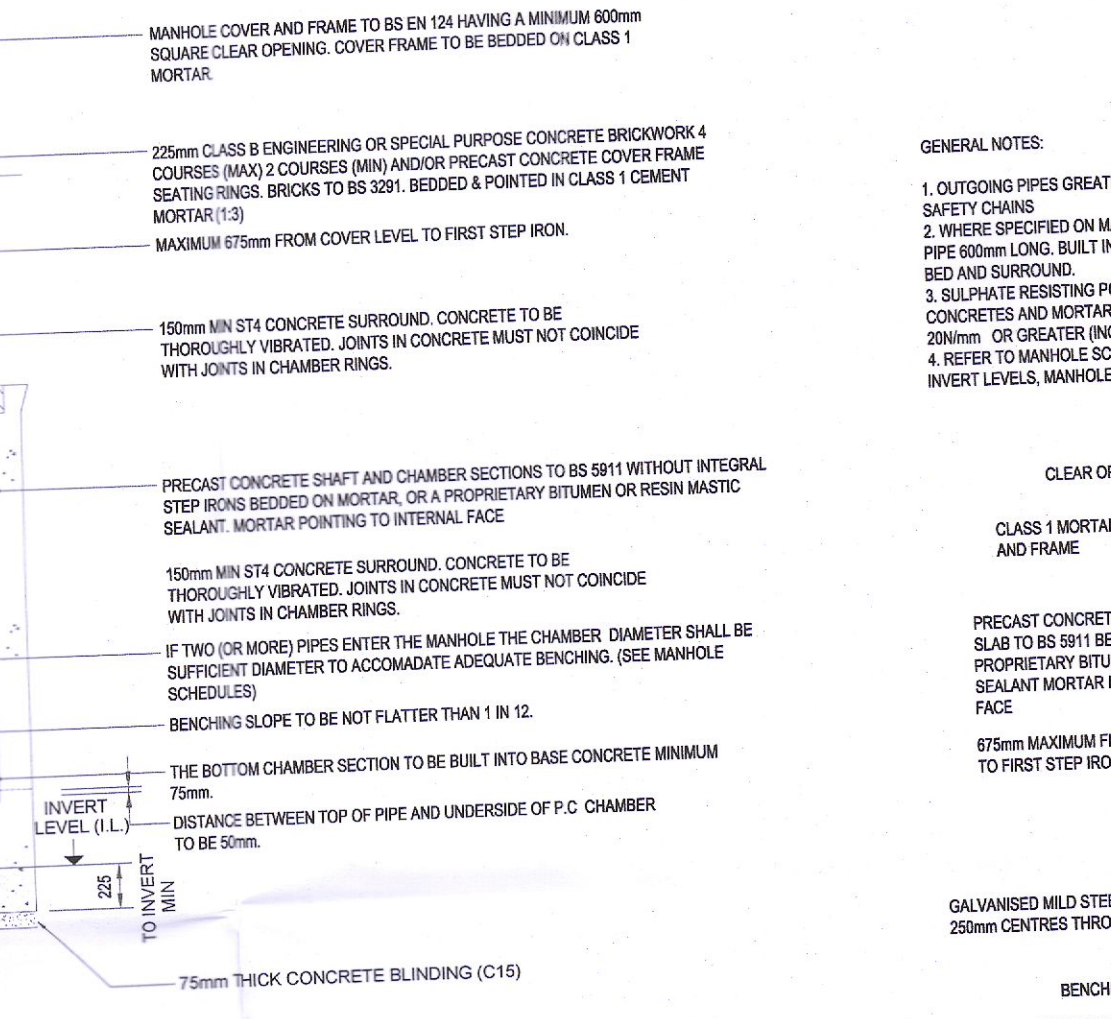
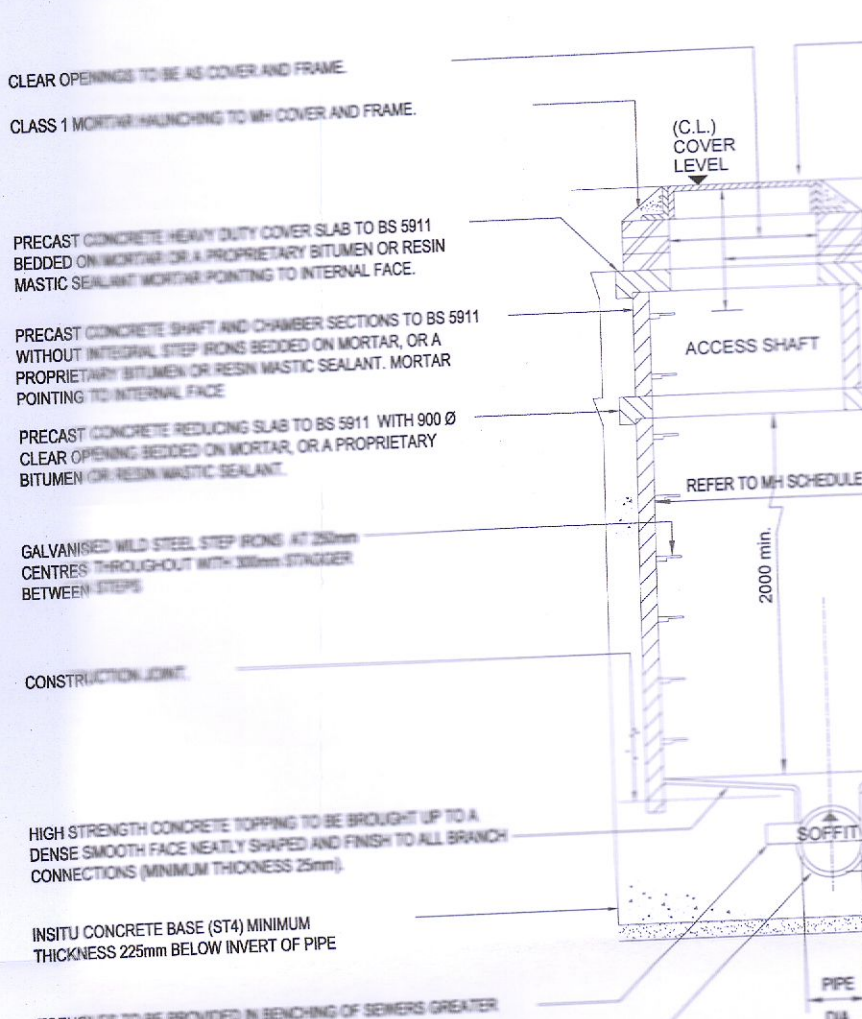

REV	DESCRIPTION	BY	CHK	DATE

CLIENT: CAPAMI LTD

PROJECT: OLDCOURT OCIL 4

DRAWING TITLE: DRAINAGE DETAILS

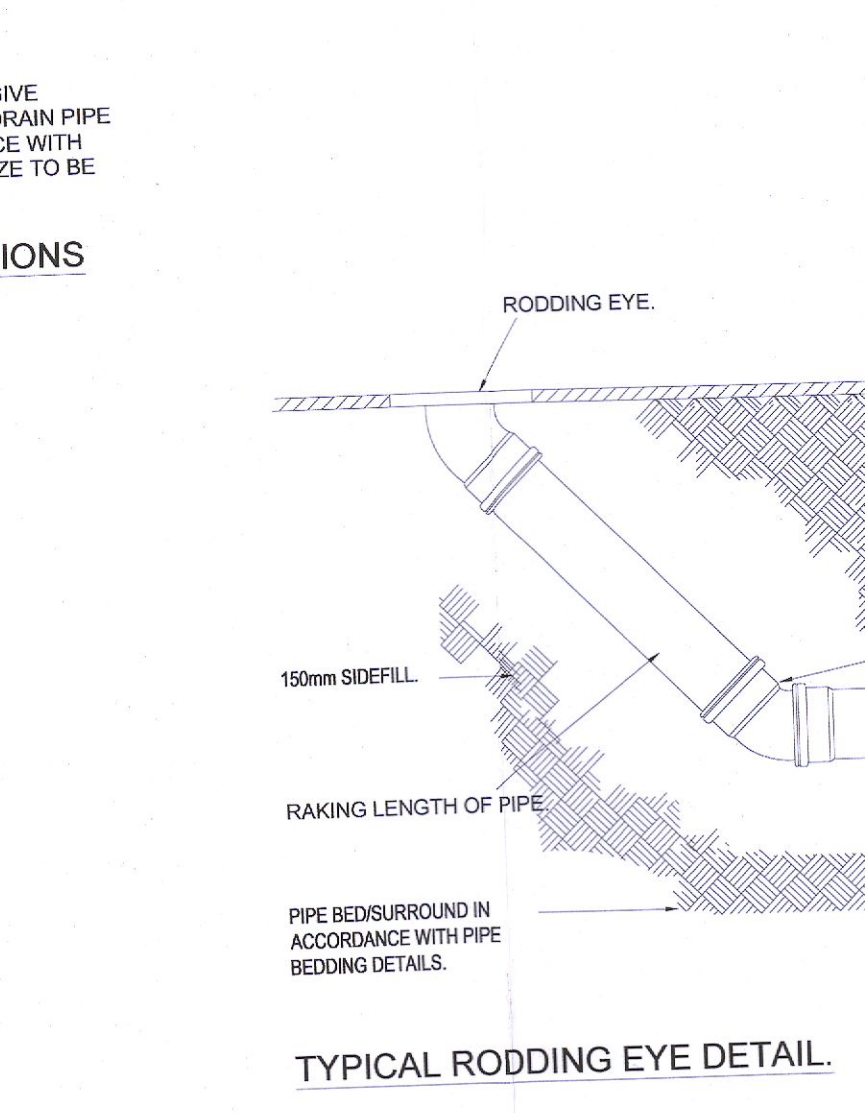
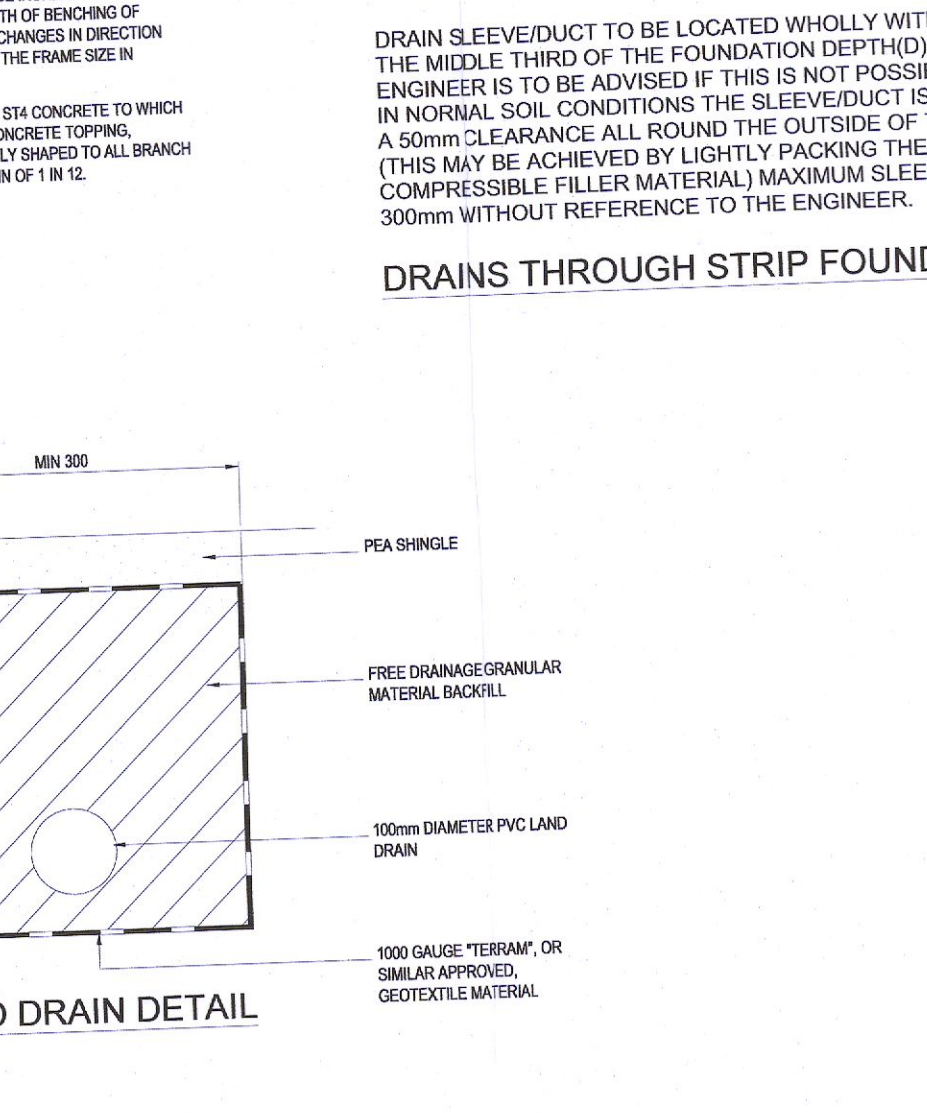
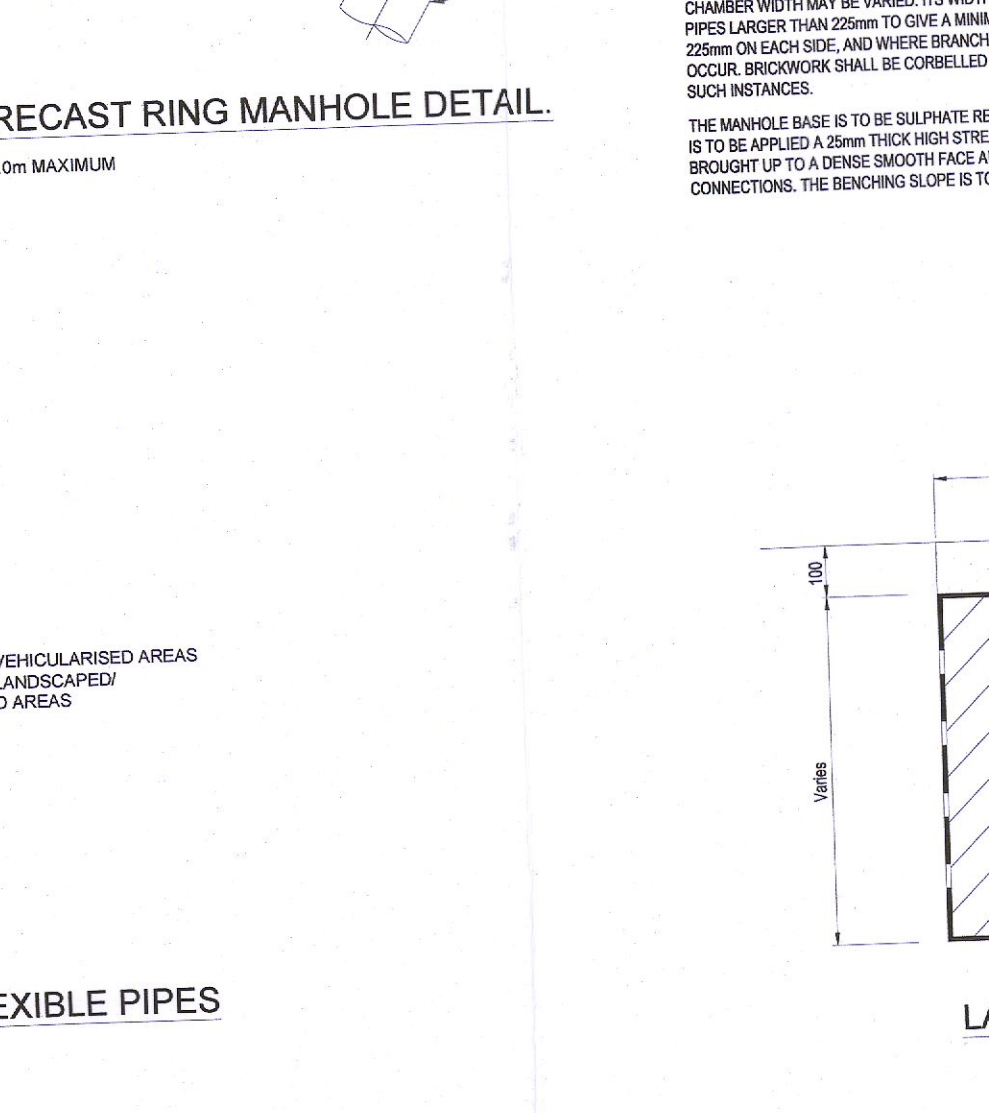
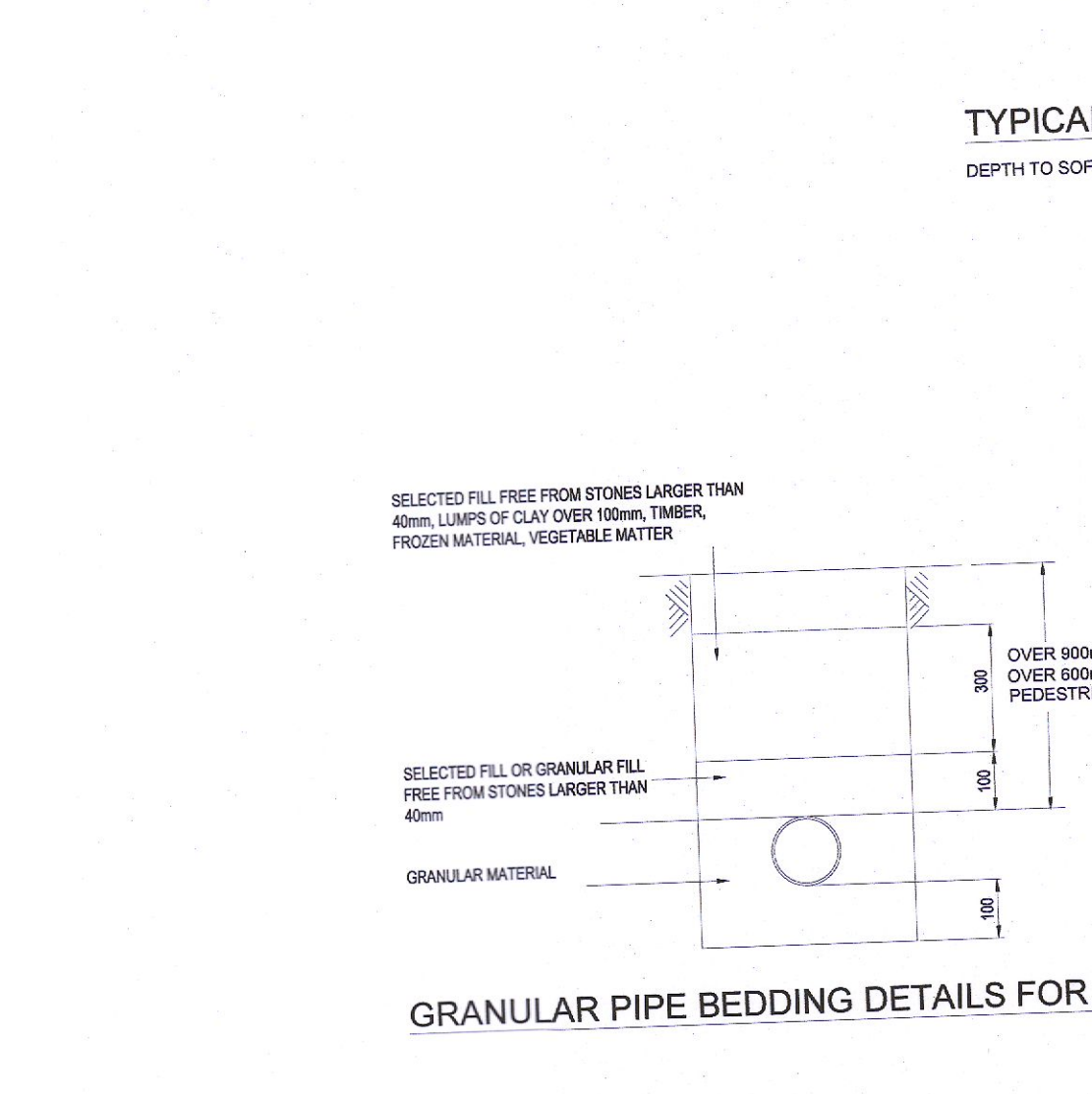
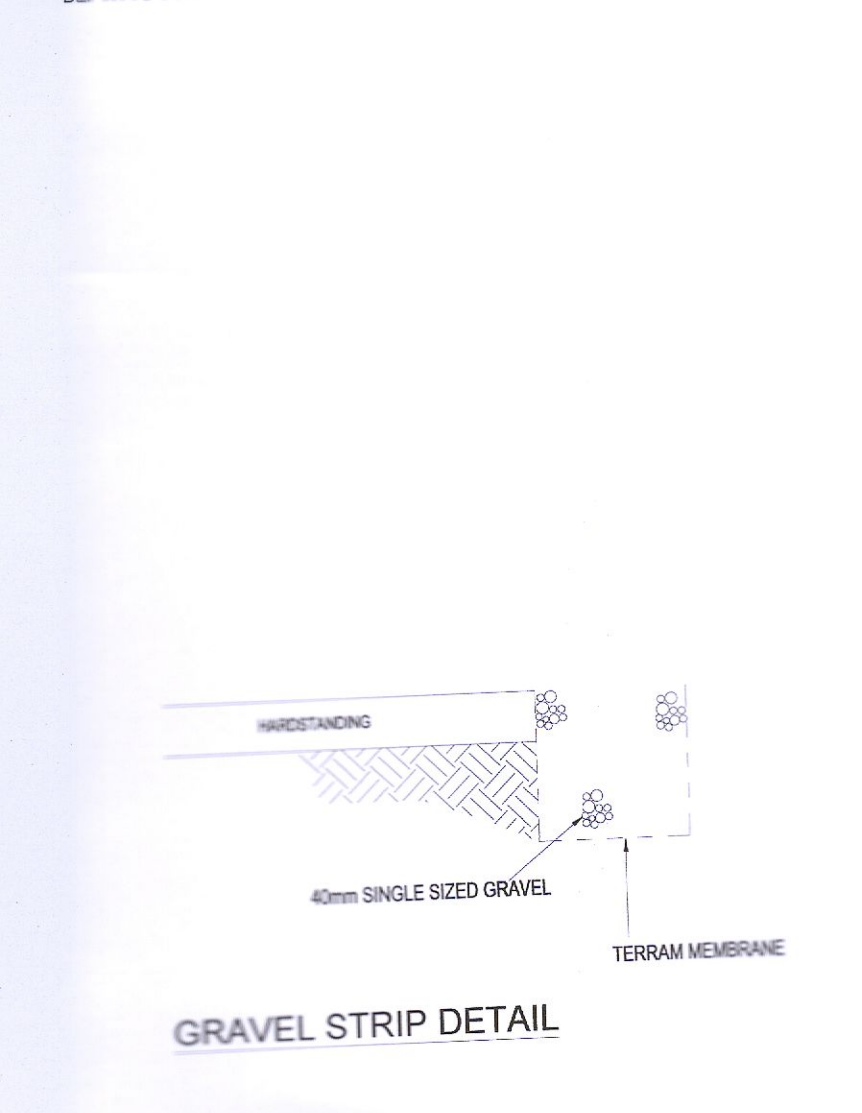

PROJECT: OLDCOURT OCIL 4

DRAWING TITLE: DRAINAGE DETAILS

**PINNACLE CONSULTING ENGINEERS**

GRUVENOR COURT, 67A PATRICK STREET, DUN LAOGHAIRE, COUNTY DUBLIN IRELAND. TELEPHONE: +353 1231 1041

WELWYN GARDEN CITY | NORWICH | LONDON | THE HAGUE

DRAWING STATUS: IRISH WATER SUBMISSION

SCALE @ A1	DATE	DRAWN BY	CHECKED
1:500	JAN '22	FJVR	SO'R

DRG NO: P190302-204

REVISION: -

COPYRIGHT PINNACLE