



01 Proposed Site Plan - Entrance
PA 002 1:200

NOTES:
 Do not scale from this drawing.
 Any discrepancies found on site to be reported to Darmody Architects immediately.
 Any discrepancies found on drawings to be reported to Darmody Architects immediately.
 Refer to engineers drawings for structural details.
 All dimensions sized to blockwork.

Rev.	Description	Date	Initials

DRAWING KEY	
	Delineates Site Boundary
	Proposed New Intervention to Existing Structure
	Refer to Existing & Proposed Plans/Elevations Drawings

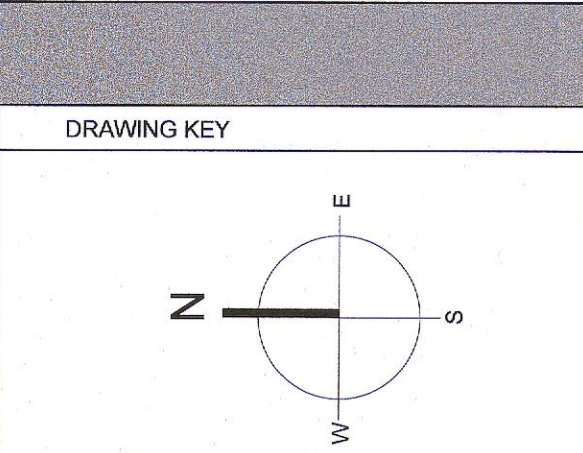
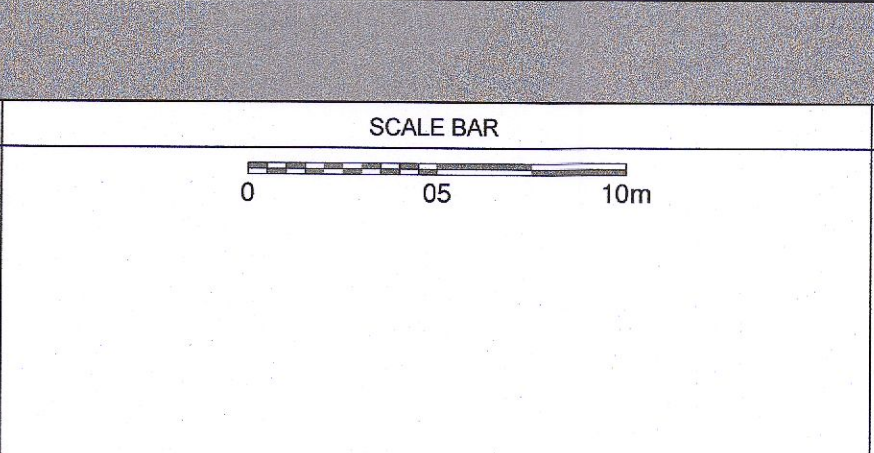

creative innovative flexible

darmody
 architecture
 91 Townsend Street, Dublin 2
 353 1 672 9907
 info@darmodyarchitecture.com
 darmodyarchitecture.com

Rev. No.	Scale	Date	Dm. By	Chkd. By	Issue
	1:200 @ A1	17/05/2022	Marco Pittamiglio	Tim Darmody	PLANNING

Project	Proposed Lidl Store at Newcastle, Co. Dublin		
Title	Proposed Site Plan - Entrance		
Client	Lidl Ireland GmbH		
Dwg. No.	PA-002	Job No.	22013