

POTENTIAL/INDICATIVE ADJACENT DEVELOPMENT (SUBJECT TO SEPARATE PLANNING APPLICATION(S) BY OTHERS).

01 Proposed Site Plan
PA 001 1:500

NOTES:
Do not scale from this drawing.
Any discrepancies found on site to be reported to Darmody Architects immediately.
Any discrepancies found on drawings to be reported to Darmody Architects immediately.
Refer to engineers drawings for structural details.
All dimensions sized to blockwork.

Rev.	Description	Date	Initials

DRAWING KEY	
	Delineates Site Boundary

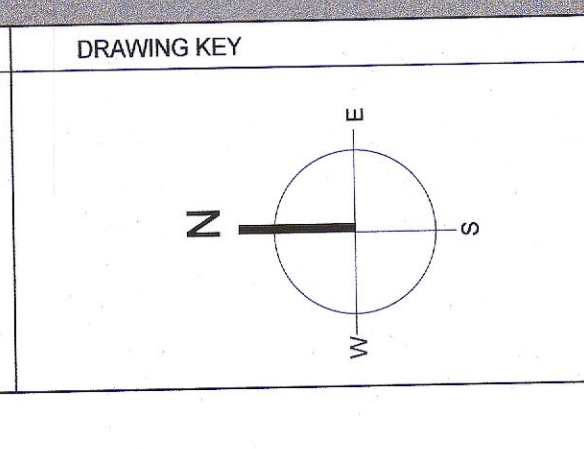
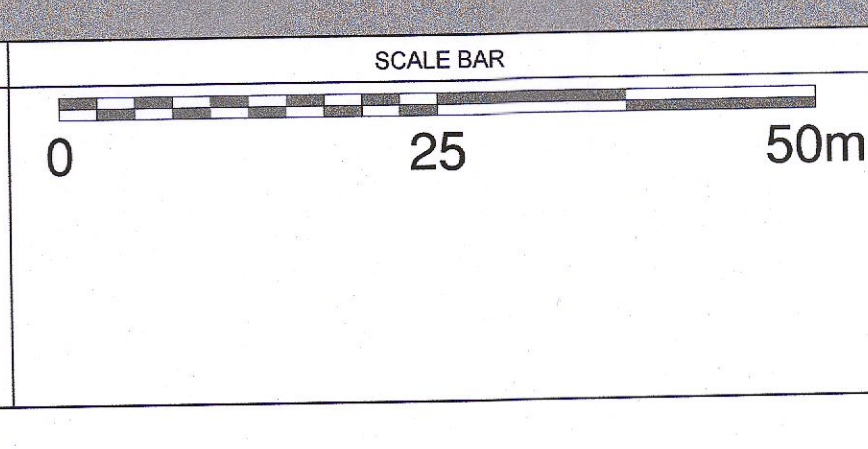

creative innovative flexible

darmody
architecture

91 Townsend Street, Dublin 2
353 1 672 9907
info@darmodyarchitecture.com
darmodyarchitecture.com

Project: Proposed Lidl Store at Newcastle, Co. Dublin	
Title:	Proposed Site Plan
Client:	Lidl Ireland GmbH
Dwg. No.:	PA-001
Job No.:	22013

Rev. No.	Scale	Date	Drn By	Chkd. By	Issue
	1:500 @ A1	17/05/2022	Kevin Barry	Tim Darmody	PLANNING