

01 Building A (Protected Structure) - Existing Ground Floor Plan  
EX 100 1:50

02 Building A - Existing First Floor Plan  
EX 100 1:50

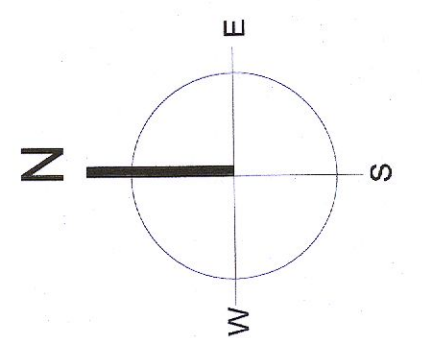

NOTES:  
Do not scale from this drawing.  
Any discrepancies found on site to be reported to Darmody Architects immediately.  
Any discrepancies found on drawings to be reported to Darmody Architects immediately.  
Refer to engineers drawings for structural details.  
All dimensions sized to blockwork.

Rev.	Description	Date	Initials

XREF'S  
CAD REF.

DRAWING KEY	
	Building Fabric to be Removed
	Outline of Protected Structure
	Existing Structure to be Retained

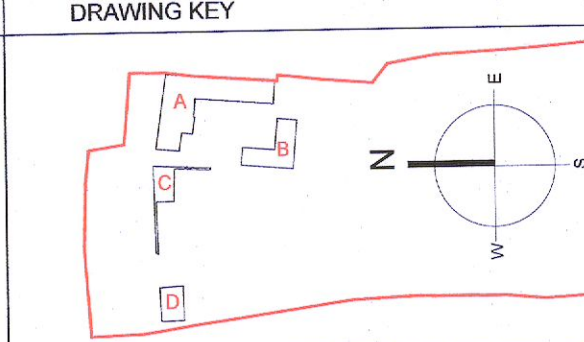
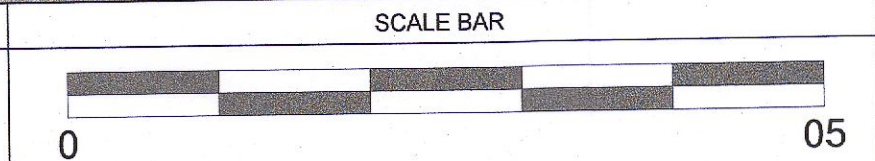

creative innovative flexible



**darmody**  
architecture

91 Townsend Street, Dublin 2  
353 1 672 9907  
info@darmodyarchitecture.com  
darmodyarchitecture.com

Rev. No.	Scale	Date	Drn. By	Chkd. By	Issue
	1:50 @ A1	11/05/2022	Kevin Barry	Alan Ryan	PLANNING

Project:	Proposed Lidl Store at Newcastle, Co. Dublin
Title:	Building A - Existing Plans
Client:	Lidl Ireland GmbH
Dwg. No.:	EX-100
Job No.:	22013