

LEGEND

- OUTLINE OF THE SITE SUBJECT TO THIS APPLICATION
- ▨ 16.5m ARTIC VEHICLE REVERSE MOTION
- ▨ 16.5m ARTIC VEHICLE FORWARD MOTION
- ▨ 16.5m ARTIC VEHICLE FORWARD TO THE SITE MOTION
- ▨ 16.5m ARTIC VEHICLE FORWARD TO THE SITE MOTION
- ▨ FIRE VEHICLE FORWARD AROUND THE SITE MOTION

NOTE:

1. REFER TO DRAWING NO 22_043-CSE-00-XX-DR-C-2020 FOR PROPOSED SITE LAYOUT AND LEVELS PLAN
2. REFER TO DRAWING NO 22_043-CSE-00-XX-DR-C-2023 FOR AUTOTACKING LAYOUT AT ENTRANCES AND LOADING DOCKS.

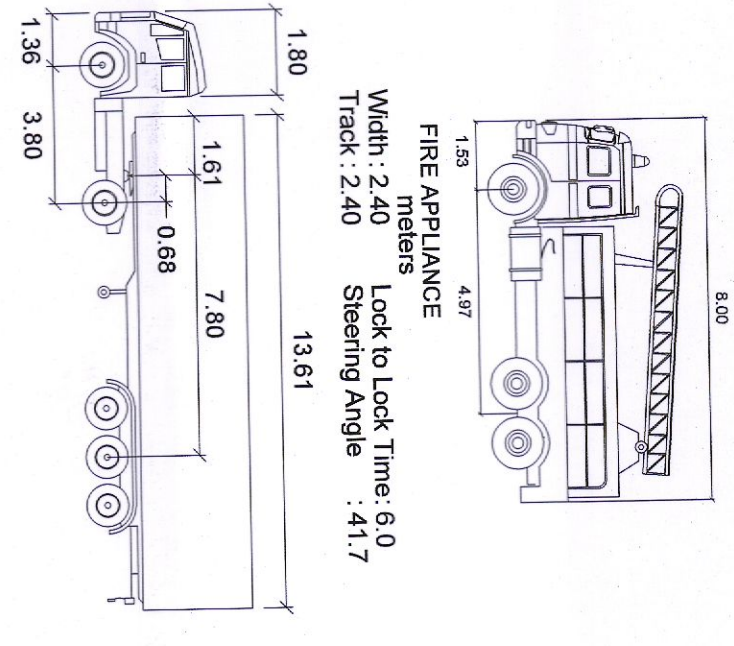

Artic
 meters
 Tractor Width : 2.55 Lock to Lock Time : 6.0
 Trailer Width : 2.55 Steering Angle : 42.7
 Tractor Track : 2.55 Articulating Angle : 70.0
 Trailer Track : 2.55

Rev	Description	Date	Drawn	Checked
P02	PLANNING ISSUE	14/07/22	LT	GD
P01	DRAFT PLANNING	21/09/22	LT	GD

Clifton Scannell Emerson Associates
 Consulting Engineers
 Reeves Road, Fintona Road,
 Dun Loughlin, Co. Dublin,
 Ireland, A99 KV20
 T: +353 1 288 8066
 F: +353 1 283 8468
 W: www.cse.ie

**K2 STRATEGIC INFRASTRUCTURE
 IRELAND LTD.**

Client: K2 DATA CENTRE
Project: PROPOSED OVERALL HGV
 AUTOTACKING MOVEMENTS
Dwg Title: 22_043
Drawn By: LT **Date:** 09/05/22
Checked By: CD **Scale:** 1:500 @ A1
Project Code: 22_043 - CSE - 00 - XX - DR - C - 2022
Originator: **Level:** **Type:** **Role:** **Dwg No.:**
Status Code: S0 **Submittal Description:** WORK IN PROGRESS
P02 **Project Status:** PRELIMINARY

