

FIRE TENDER ACCESS AND TURNING AREA.
 SCALE 1:500

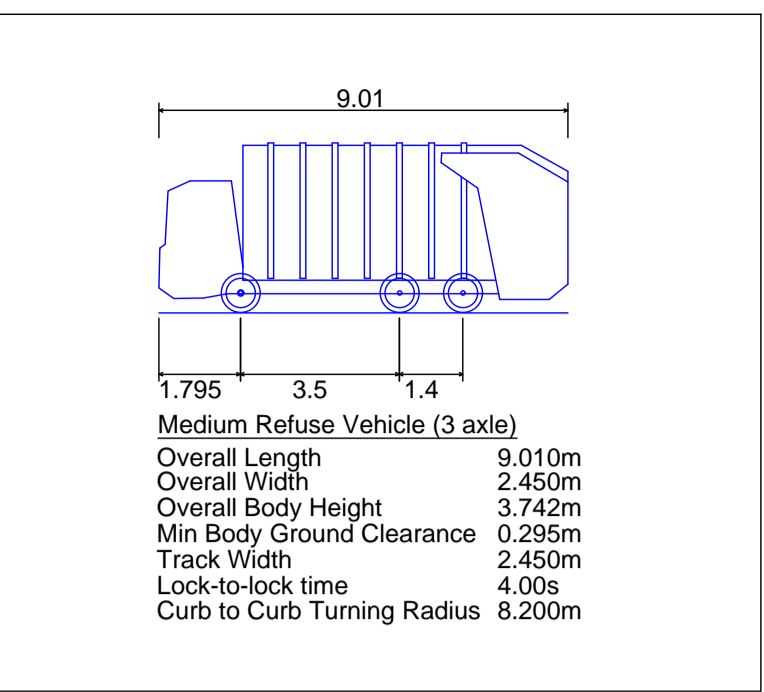

EMERGENCY VEHICLE ACCESS.
 SCALE 1:500

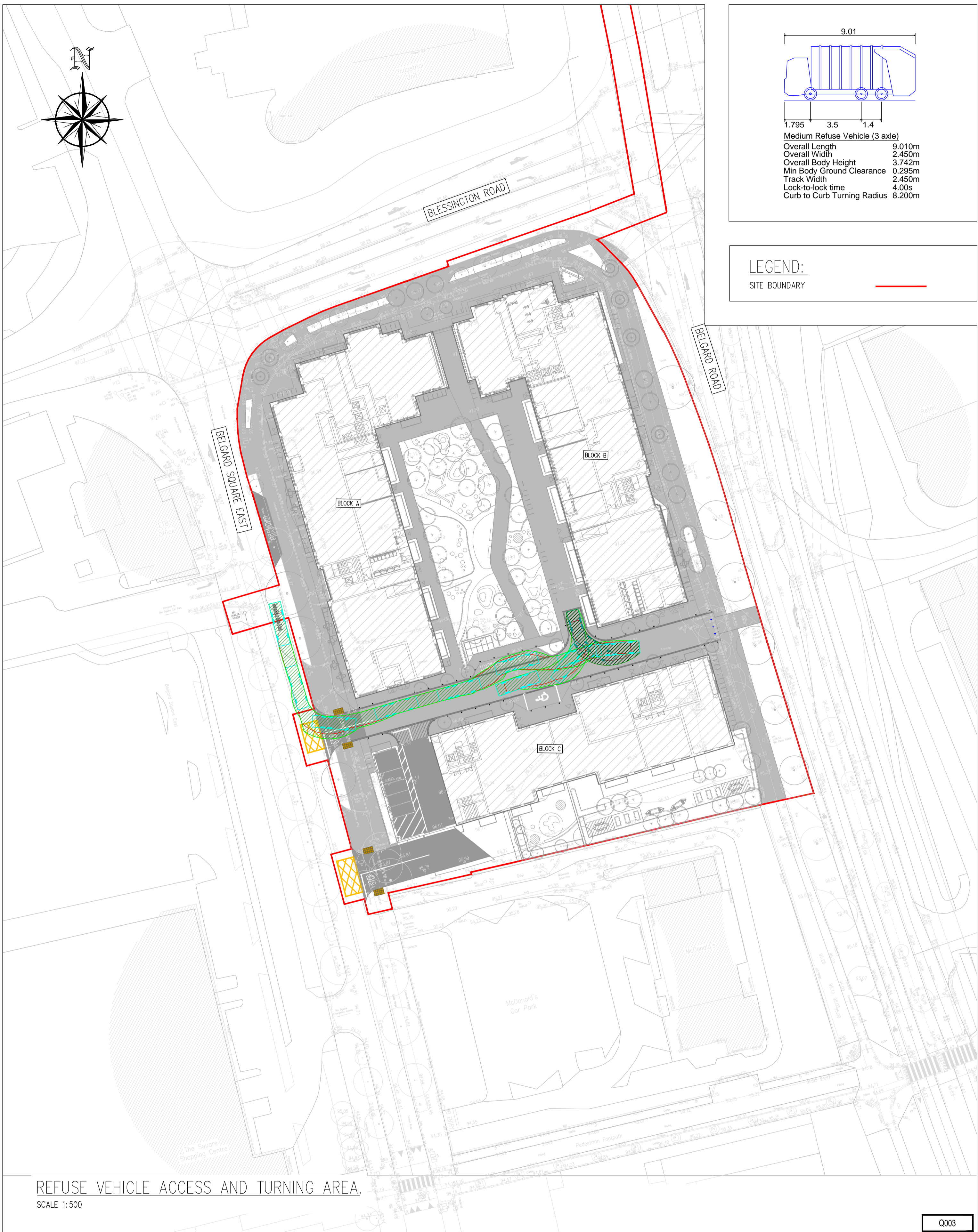

LEGEND:
 SITE BOUNDARY

REFUSE VEHICLE ACCESS AND TURNING AREA.
 SCALE 1:500

Q003

PLANNING DRAWING.
 NOT FOR CONSTRUCTION.
 ALL LEVELS GIVEN ARE
 RELATIVE TO ORDNANCE DATUM.
 THIS DRAWING HAS BEEN ISSUED FOR INFORMATION
 PURPOSES ONLY AND MUST NOT BE USED
 FOR CONSTRUCTION UNDER ANY CIRCUMSTANCES

- NOTES**
- For setting out refer to Architect's drawings.
 - This drawing to be read in conjunction with all other Architectural and Engineering drawings and all other relevant drawings and Specifications.
 - DO NOT SCALE THIS DRAWING. Use figured dimensions only.
 - No part of this document may be reproduced or transmitted in any form or stored in any retrieval system of any nature without the written permission as copyright holder except as agreed for use on the project for which the document was originally issued.
 - Ordnance Survey Ireland Licence Number EN 0074022

Rev. No	Date	REVISION NOTE	Dim. By	Chkd. By
P1	03.06.2022	ISSUED FOR PLANNING	IK	FDB

Architect	Henry J. Lyons
Project	Proposed Development On The Belgard Square East.
Title	Swept Path Analysis Fire Tender And Refuse Vehicle Access
Dwg. No.	Q003-CSC-ZZ-XX-DR-C-0009
Date	Sept 2021
Dim by	IK
Chkd by	FDB
Apprv by	NB
Scale	1:500 @ A1
Revision	P1

CS Consulting Group
 DUBLIN | LONDON | LIMERICK

Head Office
 19-22 Dame Street, Dublin 2.
 T: +353 (0)1 5480863
 e: info@csconsulting.ie
 w: www.csconsulting.ie

Quality Environment I.S. EN ISO 9001:2008
 Energy I.S. EN ISO 14001:2004
 Health & Safety OHSAS 18001:2007