

AN ROINN TALMHAÍOCHTA, BIA AGUS MARA
DEPARTMENT OF AGRICULTURE, FOOD AND THE MARINE

MINIMUM SPECIFICATION FOR HORSE FACILITIES AND FENCING

The receiving of this specification does not imply approval of a grant application. However, if written approval is issued, then this specification becomes part of the contract between the applicant and the Department of Agriculture, Food and the Marine.

This is a minimum specification. Where the word "SHALL" is used, then that standard (at least) **must** be followed in grant-aided buildings. Where a procedure is "RECOMMENDED", this is advice only on good practice.

Note that all references to other Department Specifications are to the current edition of that specification [available on the Department of Agriculture, Food and the Marine website (www.agriculture.gov.ie) under Farm buildings]. Similarly, references to Standards are to the current edition of the Irish, British or European Standard, as appropriate. Also note that for all field and paddock fencing for horses please refer to Department of Agriculture, Food and the Marine specification S148.

1 Safety

1.1 Responsibility for Safety

Applicants are reminded that they have a duty under the Safety, Health, and Welfare at Work Act 2005 to provide a safe working environment on the farm, including farm buildings, for all people who may work on that farm. There is a further duty to ensure that any contractor, or person hired to do building work, provides and/or works in a safe environment during construction.

1.2 Safety during Construction

Farmer/Applicant Responsibility: Please note that neither the Minister nor any official of the Department shall be in any way liable for any damage, loss or injury to persons, animals or property in the event of any occurrence related to the development and the applicant shall fully indemnify the Minister or any official of the Minister in relation to any such damage, loss or injury howsoever occurring during the development works. It is the applicant's responsibility to provide a construction stage project supervisor.

Dangers: Where the applicant/farmer is undertaking any part of the above work, it is his/her responsibility to seek competent advice and to undertake all temporary work required to ensure the stability of excavations, superstructure, stanchion foundations, wall foundations, to guard against possible wind damage and to avoid any other foreseeable risk. It is also his/her responsibility to ensure that any drains, springs or surface water are diverted away from the works.

Power lines: Due to the complex criteria involved, where buildings are proposed within 35 metres of the centre of any overhead power line, the landowner shall contact ESB Networks in advance to ascertain the specific minimum building clearance requirement. It is a requirement

on landowners under The Electricity Supply Acts to notify ESB Networks, at least, two months before commencement of any construction works near overhead lines. As a guide, table 1 below sets out the usual minimum clearance distances required, however, ESB Networks shall be contacted and their advice followed for any structure within 35m of the centre line of an overhead power line. ESB will provide landowners with written confirmation of the required clearances. Landowners can contact ESB through phone numbers provided on their electricity bills.

Where building work is undertaken near power lines there is also a safety issue regarding Machinery, Tipper Trucks and Elevators operating without proper safety measures in place. When landowners contact ESB they will be provided with relevant safety literature.

Table 1: In general the following clearances apply to various voltage levels.

Voltage	Clearance
Low Voltage	0.5 to 3 Metres
Medium Voltage	3 to 6 Metres
38KV Lines	10 to 17 Metres
110kv Lines	23 Metres
220KV Lines	30 Metres
400KV Lines	35 Metres

Note:

- ESB overhead lines consist of lines at various voltage levels and require specific safety clearances from buildings depending on voltage level and construction type.
- Clearances are specific to the line voltage, building height, location in line span and ground levels.

Danger to children: It is the applicant’s responsibility to prevent children from playing or spending time in the vicinity of any construction work.

Roof work: When working on any roof, it is essential to assume that the roof is fragile, unless confirmed otherwise by a competent person.

The HSA Code of Practice for Safety in Roofwork shall be consulted prior to any work being undertaken on a roof. All advice in the code of practice shall be followed.

The HSA code of practice gives recommendations and practical guidance on how to work safely on roofs, including the safe maintenance of roof mounted plant and services, and how to design and plan for safe working. It offers guidance on the design and construction of roofs on new buildings and the maintenance, cleaning and demolition of existing roofs. All work at height poses a risk and a risk assessment should be carried out to assess those risks and put appropriate controls in place.

1.3 MAINTENANCE

All farm buildings require regular maintenance to ensure the health and safety of personnel and animals. After each winter-season buildings should be thoroughly washed and cleaned out. Fittings such as slats, electrical fittings, drinking arrangements, etc., should be periodically checked, and all defective items replaced.

Horse Exercisers/Walkers should not be left unattended when in use, as there is a risk of injury to the horses, if a horse falls in the walker. A safety sign shall be clearly displayed

indicating that "THIS MACHINE SHALL NOT BE LEFT UNSUPERVISED WHILE IN OPERATION".

2 Approved manufacturers of proprietary horse facilities (S157)

Lists of the accepted manufacturers of proprietary stables, horse walkers/exercisers and prefabricated lunging areas (S157) are available on the Department of Agriculture, Food and the Marine website (<http://www.agriculture.gov.ie>) under farm buildings. Only the manufacturers on these lists can supply and construct proprietary stables, horse walkers/exercisers or prefabricated lunging areas when a grant is being sought.

3 Concrete Specification

Concrete shall be to the standard set out in the Department of Agriculture, Food and the Marine specification S101 and shall be certified in the same manner.

4 Electrical Installations

Wiring and fittings shall be installed, and all work shall be carried out in accordance with the Fourth Edition of the National Rules for Electrical Installations, ET101:2008 specifically Part 7-705: Requirements for special installations or locations - Agricultural and horticultural premises. An ETCI completion certificate shall be required, signed by the Electrical Contractor(s) or a person duly authorised to act on his/her behalf to certify that the electrical installation has been constructed and/or has been tested according to the National rules of Electrical Installations and has been found to be satisfactory. An associate certificate, specifically for agricultural work, the "Supplementary Agricultural Certification Form" shall also be signed by the Electrical Contractors or authorised persons and the number of the main ETCI completion Certificate clearly marked on it. If no valid numbered ETCI Certificate is available for the completed installation, then the Electrical Contractor shall complete a new numbered ETCI Certificate indicating that the new installation has been tested for safety and compliance, and note that number on the Supplementary Form. The signed printed "Supplementary Agricultural Certification Form" together with a copy of the ETCI Completion Certificate shall be given to the Department before grant-aid can be finally certified.

5 Site

Sites for stables or housing shall be dry, not subject to flooding, and convenient to fodder, waste storage, and other facilities. Clean water from roofs and yards shall be piped away to avoid contamination with soiled surfaces.

Sites for Lunging Areas or Special Exercise Areas shall be dry, level, not subject to flooding, and be convenient to stables or housing. Sites for Gallops shall be dry and not subject to flooding.

For safety considerations Lunging Areas, Special Exercise Areas, and Gallops shall be sited at least 10m from any public road.

The above sites shall be adjacent to either a surfaced roadway, or to a drained and gravelled pathway.

6 Housing of Horses

Horses may be housed separately in loose boxes or stalls, or paired in loose boxes, or loose-housed in groups of three or more. Loose boxes or stalls may be built separately; or built together in various arrangements; or grouped together under a single roof (American Barn).

6.1 Horse Houses – Types and Sizes

6.1.1 Loose Boxes

Loose Boxes shall be sized according to their expected use. For ponies/small horses the minimum size shall be 8m², with 2.8m the minimum length of the shorter wall. Boxes for larger horses shall be in the range 11-20m², and shall be as square as is practical. The minimum length of the shorter wall shall be at least 3m.

Boxes for foaling shall have a minimum size of 20m², with 4m the minimum length of the shorter wall.

Boxes for stallions shall be at least 15m² with 3.5m the minimum length of the shorter wall.

The maximum size for a foaling box or for a stallion box is 25m², for other boxes the maximum size is 20m².

6.1.2 Stalls

Stalls shall be at least 1.8m long (including trough space) and 1.5m wide. The service passage behind the stalls shall be at least 2m wide for a single row of stalls, and 3m for a double row. Feeding passages, where used, shall be at least 1m wide. Stall dividers, 1.4m high, shall be of solid timber, blockwork or other proprietary material accepted by the Department.

6.1.3 Loose Housing

Loose Housing (i.e. group housing of three or more animals). The following floor areas are suggested, with the lower figure being the minimum.

- Weaned Foal: 2.5-4m²
- Yearling: 4-6m²
- Adult Horses: 8-12m²
- Mare and Foal: 12-16m²

6.2 Building Structure

6.2.1 Roof Structure

All roof structures shall comply with Department of Agriculture's specification S101. Alternative proprietary construction systems (e.g. of protected timber) may be used if such systems have received the prior acceptance of the Department. Gutters and downpipes shall be fitted to all roofs and arranged so as not to discharge onto soiled yards. All metal cladding fixed to timber rails or purlins shall be separated by a layer of DPC.

Roofs under tiles or slates shall be of Traditional construction, with batten spacing, etc., in accordance with manufacturer's instructions.

6.2.2 Roof and Side Cladding

Cladding materials and their installation shall conform to the current edition of S102. Slates or tiles may be used, installed according to manufacturer's instructions.

6.2.3 Ceilings

Ceilings are not required. If installed, they shall follow the slope of the rafters/purlins, and shall **not obstruct** the outlet ventilation at the apex.

6.2.4 Permanent Open Ventilation

Permanent open ventilation shall be provided as a strict condition of grant aid. Opening/closing windows, or opening/closing half-doors, **shall not be included** in the required inlet/outlet areas given below. Air inlets shall be at least 2m above floor level and air outlets at least 1m above the inlet.

Inlet(s) 0.3m²/adult animal

Outlet(s) 0.15m²/adult animal, though 0.3m²/adult animal is strongly recommended.

Inlet area is defined as the aggregate area of all unobstructed air inlets. (i.e. if Yorkshire boarding, or other system, is used to reduce wind speed, the area of the timber/plastic is not part of the inlet area). Permanently open half doors are a useful method of achieving inlet ventilation. Vented sheeting may be used for inlet ventilation only, in such cases a minimum of 1.5 m² of vented areas of sheet shall be provided per adult animal.

American Barns shall have a ridge opening at least 300 mm wide. If a ridge cap is fitted, there shall be a clear space of at least 175mm on both sides between the cap supports and the roof.

6.2.5 Foundations

Foundations for walls shall be excavated to a depth of 600mm below ground level, or until firm strata is encountered.

Concrete footings shall be at least 225mm deep, and as wide as the wall to be carried plus 225mm on each side. Where backfill material is used under infill walls, the backfill material shall be thoroughly compacted in layers not exceeding 150mm before foundations are laid. Foundations shall be formed in concrete at least 300mm deep and 600mm wide. It is recommended that steel reinforcement bars (a minimum of 4 No. 12mm bars, fixed 50mm from bottom of concrete) should be incorporated into concrete foundations on compacted backfill.

In cases where fill is purchased for use under concrete, it shall be certified to EN 13242:2013 and meet the requirements of Annex E of S.R. 21: 2015. This material shall also be used as the top 300mm of any backfill around stanchion foundations.

6.2.6 Walls

Walls shall be 225mm solid block with continuous wall plate to support the roof, or have 450mm x 450mm solid blockwork piers as roof supports. Infill walls between stanchions/piers at 4.8m centres (or less) shall be 150mm solid blockwork, which shall be firmly secured to stanchions/piers. Internal walls shall be of 150mm solid blockwork.

All block walls shall be of solid blocks that are certified to a minimum strength of 7.5N/mm², though it is strongly recommend that they be constructed of mass concrete. All blocks used shall be produced in a plant certified to EN 771-3:2011 and shall be CE marked. The use of hollowcore blocks is not permitted.

A damp-proof course shall be fitted not less than 100mm above floor/yard level for all blockwork walls.

Walls in boxes shall be not less than 2.4m high. Walls in loose houses, stall houses and barns shall be of solid construction up to 2.4m, with a minimum eaves height of 3m. All internal walls shall be smooth-plastered with 5:1 sand-cement mix, steel-trowelled. External walls shall be smooth-plastered or be constructed of fair-faced blockwork, well pointed.

Walls may also be of 200mm mass concrete with pillars at 6.4 m, or 150mm where built between stanchions at 4.8m centres. All blemishes in the concrete surface shall be finished smooth. Mass concrete in-fill walls shall be constructed with nominal mesh reinforcement. (Minimum mesh A98: 5mm at 200mm x 200mm: 1.54kg/m²). Mesh shall be placed on outside face of wall with 40mm concrete cover. It is strongly recommended that gable walls should be in mass concrete. Any blemishes, tie-bar holes, or honeycombing in mass concrete walls shall be filled/repared with an accepted, non-shrink proprietary cement mortar.

Proprietary pre-cast concrete wall panels may also be used for infill walls, if accepted by the Department of Agriculture, Food and the Marine. Proprietary precast concrete wall panels shall require prior Departmental acceptance and be listed on specification S101A of the Department of Agriculture, Food and the Marine. All Proprietary precast concrete wall panels shall be CE marked and produced in a plant certified by a Notified body (e.g. NSAI or equivalent), to produce precast concrete wall panels to EN 14992:2007 +A1:2012.

A horizontal cast-rail formed in the plaster, (or in the concrete), 1.3-1.5m from the floor is recommended. It shall be formed as a groove 12 mm deep at the top and sloping down 50mm to meet flush with the plastered wall.

Where partitions between adjoining loose boxes are to be made of timber, the timber shall be a minimum thickness of two sheets of 18mm marine plywood or equivalent.

Proprietary wall panels for internal stables shall consist of a galvanized steel frame with timber or composite infill for the entire wall to a minimum thickness of 18mm and or alternatively up to a minimum height of 1.15m, where the top half may be consist of galvanized steel bars. The height of the wall panel shall be a minimum of 2.4m. All timber edges shall be inaccessible to housed animals. These panels shall require prior Departmental acceptance, and may be subject to requirements for certificates of guarantee. Sliding partitions to facilitate cleaning are acceptable provided they are from a Department approved manufacturer. Under no circumstances shall such partition be hinged or swinging.

6.2.7 Floors

Solid Floors shall be a minimum 125mm concrete laid smooth with a non-slip finish. Concrete shall comply with Clause 3 above. A minimum 150mm hard-core base shall be laid, compacted with vibrating or heavy roller, and topped with fine sand. All floors shall incorporate 1000 gauge polythene DPC membrane with 600mm overlaps laid on the sand under concrete. The polythene membrane shall be taken up along walls to meet DPC where this has been installed.

The slope of the floor in boxes/stalls or loose houses shall be at least 1 in 60. A grooved, or otherwise slip-resistant, floor finish is required.

Central passages in American Barn Houses shall be at least 4m wide.

In cases where fill is purchased for use under concrete, it shall be certified to EN 13242:2013 and meet the requirements of Annex E of S.R. 21: 2015. This material shall also be used as the top 300mm of any backfill around stanchion foundations.

6.2.8 Doors

Doors to boxes shall be of timber, or of galvanised steel, or of composite construction. Timber edges shall be inaccessible to housed animals, or shall be protected by metal channels. Doors shall be 2.4m high, and 1.2m wide. In Barns sliding doors shall be fitted to all boxes: doors to external boxes may be hinged or sliding. The top half of the door shall either be hinged separately, or be of open grid construction. All hinged doors shall have fittings to allow secured fixing back to the wall. Vee-shaped "anti-weaving" grids are recommended on loose-box doors.

Sliding external doors, 3m high, shall be fitted to American barns, or loose houses.

6.2.9 Lighting

Translucent roof sheets shall be installed in American Barns and loose houses to provide sufficient even natural light. Roof lights or windows or permanent open grids shall be installed in loose boxes/stalls to provide sufficient natural light. Windows shall be at least 2m from floor level, and protected on the inside with a fine metal screen.

Artificial lighting, normally fluorescent tubes, shall be in damp-proof fittings, and shall be installed with one fitting per loose box, or equivalent in other housing systems. All electrical work shall conform to the "National Rules for Electrical Installation". Switches shall not be fitted inside boxes, and all conduit, sockets, etc., shall be out of reach of animals.

6.2.10 Water Bowls and Manger Fittings

Each box shall normally be fitted with a water bowl and a manger, at 0.9 - 1.1m from floor level. Where water bowls are not fitted, there shall be a tapped water supply closely adjacent to the box(es). A tying ring, 1.5 - 1.7m from floor level, shall be fitted.

Loose Houses shall be fitted with water bowls and tying rings. Stalls shall be fitted with water bowls, troughs, and tying rings.

All water pipes shall be manufactured in compliance with IS EN 12201 and be a minimum of PE40. These will either be fully blue or have a blue longitudinal strip.

6.2.11 Tack Room

Tack rooms may be installed in line with loose boxes, either freestanding or in barns, or may be installed separately. They shall be constructed to the same general standard as boxes, except that for internal walls well-pointed fair-face blockwork may be used without plaster.

Sliding doors or swing doors shall be installed in tack rooms in American barns. It is recommended that these doors have a secure locking mechanism.

The maximum size of grant-aided tack rooms is 16m².

6.2.12 Feed Storage

Feed may be stored in haybarns or other equivalent stores, built to S.101; or within specified areas in loose houses or American Barns. Meal may also be similarly stored, or kept in proprietary bins.

6.2.13 Apron

A working apron, minimum 2m wide, shall be provided along the front of loose boxes and loose houses, of 125mm concrete on 150mm well compacted hardcore. An extended roof or canopy, 1m-1.5m wide, shall be provided over the apron. No part of the canopy shall be less than 2.4m from floor level.

6.2.14 Waste Disposal

A shallow channel, 30mm deep, to collect wash-water shall be provided outside each box or behind each stall. It shall be connected to a soiled water tank. If the tank is separate, it shall have a minimum size of 0.3m³ per week, which will accommodate six horses, with an additional 0.05m³ per week for each extra horse. However, the channel may also be connected to any suitable larger tank in the yard.

All solid farmyard manure and soiled water shall be stored in compliance with the requirements of S.I. 31 of 2014 European Communities (Good Agricultural Practice for Protection of Waters) Regulations and any subsequent amendments to the regulations.

Where a manure pit is required, it shall be constructed in accordance with Department of Agriculture, Food and the Marine specification S108, and solid water tanks shall be constructed in accordance with Department of Agriculture, Food and the Marine specification S.123.

7 Horse Stocks

7.1 Site for Stocks

It is recommended that stocks are installed internally in any suitable building, but where they will have limited use they may be placed externally in the yard. Stocks shall be installed so that the horse may enter easily, and exit from the front with a clear space of 1.5m between the stock and the front wall. Penning or gates shall allow a secure space alongside, or in front, where a foal can be held in clear view of a mare in the stock.

The floor of the stock and of the adjacent walking area shall be of grooved non-slip concrete. It is recommended that there should be drainage for disinfectant and wash-water from this floor, to be connected to an adjacent suitable holding tank.

7.2 Construction

Stocks shall be strongly constructed of timber or hollow steel section. Steel shall be galvanised to I.S. EN ISO 1461:1999. Stocks may also be of proprietary manufacture.

Timber posts shall be a min. of 125mm x 125mm, and steel posts a min. of 50mm x 50mm or 50mm OD round.

The stock shall be securely fixed to the floor, normally with heavy-duty rawlbolts, but steel posts may be fixed in position before the concrete floor is poured.

The entrance and exit doors shall be of steel construction, or of solid timber encased in a galvanised steel frame. Doors shall be lined internally with a 6mm rubber lining, or a strong washable padded lining. Suitable heavy-duty hinges shall be fitted.

Sidewalls may be installed of 50mm timber or other construction with padded/rubber lining, or the horse may be restrained simply by timber rails (min. 100mm square) or 50mm galvanised steel rails. It is strongly recommended that rails should be padded, and also fitted to allow for quick release.

Connecting rails shall be installed at the top to ensure rigidity. The front top rail shall be padded to prevent head injury to the animal.

7.3 Stock Dimensions

Stock dimensions are critical, so that the horse is both comfortable and also firmly restrained. Dimensions (as below) should be determined for the size of the animals to be restrained.

The clear inner length between the doors shall be between 1.8 and 2m. The width between the side rails or walls shall be between 670 and 900mm. The top of the posts shall be a minimum of 2.25m above floor level. Side rails may be fixed or adjustable: The top of fixed rails or sidewalls shall be between 1.2 and 1.4m from floor level.

The height of the rear door shall be between 750mm and 1.055m, and the front door height between 1.2m and 1.4m. It is recommended that the height in the rear door is adjustable to safely accommodate ponies and horses.

8 Shelter and Run / Exercise Area

8.1 Shelter Construction

The shelter shall be constructed to the Department of Agriculture, Food and the Marine specification S101 and clause 6 of this specification. The run or exercise area shall be adjacent to the shelter where the animal will have access to at all times. Please refer to item 6.2 for detailed requirements of the building structure. Please note that there is no requirement for tack rooms, feed storage, or an apron in this building. The building can be fitted with Department's approved internal stables arrangement if required.

8.1.1 Space Requirements

The minimum floor area required is as per item 6.1.3 Loose Housing.

8.2 Run / Exercise Area

This area shall be constructed to standard outlined in item 9.4.1-7 Construction of All Weather Surfaces. The maximum stocking density for the run / exercise area shall not exceed 80m²/adult horse.

8.2.1 Fencing

Fencing around the run / exercise area is to the Department of Agriculture, Food and the Marine specification S148. Timber post and rail horse fencing may be used but is not a requirement.

9 Lunging Areas, Exercise Areas, and All-Weather Gallops

9.1 Lunging Area

Lunging areas shall be either circular with minimum diameter 15m, or as square as possible with minimum dimensions of 15m x 15m and shall have an all weather surface. Where possible, a 20m square, or diameter, is recommended.

9.2 Exercise Area

Specially fenced separate exercise areas shall have a minimum size of 350m² and a shorter side of at least 15m. The riding area may be in grass or an all weather surface.

9.3 Gallop

All-weather gallops shall be a minimum 3m wide. A straight gallop shall be at least 500m long. A circular or oval gallop shall be at least 400m long, measured on the inner circumference. It is recommended that, where land is available, gallops should be about 800m long. Gallops are normally fenced, but such fencing is optional. The riding area may be in grass or an all weather surface.

9.4 Construction of an All Weather Surface

9.4.1 All-Weather Surface

All-weather construction, as specified below shall be provided for all lunging areas and gallops. Field drainage for lunging areas may also need to be incorporated on certain sites, and is normally required for gallops.

Exercise areas may be constructed with an all-weather surface, or be left in grass.

9.4.2 Lower Drainage Membrane

A lower drainage membrane shall be used when the stone drainage bed is put directly onto topsoil, in order to prevent the mixing of stones and soil. Where topsoil is removed, and the base is firm, this lower membrane is not essential. The membrane shall be of porous polypropylene or polyester material, e.g.: Polybrane or equivalent, and shall be laid and overlapped to the manufacturer's instructions.

9.4.3 Field Drainage

Field drainage shall be provided under the drainage bed for both lunging areas and all-weather exercise areas, where site considerations or local high rainfall may require rapid drainage. It is recommended that the spacing of field drainage channels does not exceed 5m. The drainage pipes used shall have a min diameter of 100mm and when layed the pipes shall be surrounded by a layer of 'Pea Gravel' as per figure 5. Basic field drainage shall be provided in all gallops unless percolation tests show that drainage is not required. The simple Percolation Test as described in EPA Wastewater Treatment Manual (Single House Systems) may be used for Percolation Tests. A field drain shall be provided in the centre of a linear gallop, or on the inner edge of a circular gallop. A pattern of herringbone drains may be connected to the main field drain in any part of the gallop where ground conditions are suspect. All drainage systems shall outfall to an adjacent drain or watercourse, or to an adequate soakpit.

In a circular gallop the main drainage bed, the membrane, and the surface, shall all be laid on a slight incline (2° - 3°) towards the inner edge.

9.4.4 Drainage Bed

The drainage bed shall be constructed of angular stones, 25mm to 50mm, with no fines, and shall be not less than 150mm in depth. The top of the drainage bed shall preferably be above ground level in lunging and all-weather exercise areas.

9.4.5 Upper Drainage Membrane

An upper drainage membrane, as specified in section 9.4.2, shall be placed over the stone drainage bed. Overlaps of the material shall be stitched together, and the edge of the membrane shall be turned up and fixed to the inside of the surface retaining board, using batons. Alternatively, a 40-50mm layer of permeable tarmac may be substituted for the upper drainage membrane. [Macadam to comply with BS 4987, Part 1:1993, Tables 17, 18, 19. e.g. Group 3:-14mm open graded macadam]. A 30mm layer of sand shall first be consolidated over the stone drainage bed before the tarmac is laid.

9.4.6 Retaining Boards

Creosote Treated Surface Retaining Boards, 40mm thick, shall be used to confine the surface material. The top of these retaining boards shall be 150mm above the finished height of the exercise area. These boards shall be supported at 1.2m intervals using a combination of posts driven into the ground and the fencing posts. Retaining Boards are optional on gallops. Where they are not provided the side earth shall be banked at about 60° , and the all-weather surface shall finish at 50-75mm **below** ground level.

9.4.7 Surface Material

All riding surfaces shall be a minimum of 350mm deep. The following surface materials are acceptable (a) Wood chips; (b) Washed sand, or clean pit-run sand; (c) Granulated PVC; (d) Rubber chips; (e) Latex covered sand; (f) combinations of these; (g) crushed glass (diameter 0.1-2.0mm, only purchased from accepted manufacturers); (h) polypropylene fibres, or other accepted surface. Wood chips, PVC, and rubber chips, shall be of a size to pass through a 15mm screen. Bark, peelings, rubber tiles or sawdust are not acceptable. Washed sand, or clean pit-run sand, shall be totally free of soil, and be laid to a minimum depth of 225mm., with a surface slope of 1 in 60. Sand shall be uniform grade (80% approx. between 0.15mm – 0.5mm particle size). Limestone sand will require more maintenance than non-lime sand, and should be avoided if possible.

9.4.8 Fencing of Lunging/ Exercise Areas

All fencing shall be to the standard as outlined in the Department of Agriculture, Food and the Marine specification S148. All post and rail fencing shall also comply with Irish Standard I.S. 437. Only creosote treatment is accepted for this type of fencing.

Fences shall be **at least 1.75m high**, and be constructed as Post and Rail Fences with a minimum of 3 rails or of proprietary prefabricated fencing. The height of the fence shall be measured from the ground level from the top of the riding surface to the top of the top rail (See figure 5).

9.4.9 Post and Rail Fence

Posts shall be rectangular, minimum dimensions 150mm x 75mm (preferably 150mm x 100mm), be at least 2.55m long, and be placed 0.8m into the ground. Rails shall be 100mm by 38mm. Maximum spacing of posts is 2.4m. Galvanised nails or screws shall be used. Rails shall be on the arena side of the fence. Post and rail fences may be constructed of proprietary PVC systems that have been previously accepted by the Department.

9.4.10 Gates

Gates in lunging/exercise areas shall open both inwards and outwards; shall be at least 3m wide; shall be unsheeted; and when erected they shall be at least 1.75m high. Gates may be of wood or galvanised steel. Wooden gates shall have 4 horizontal 100mm x 40mm rails and be suitably constructed and braced. Steel gates shall be heavy-duty type, and otherwise conform to IS 155:1967.

9.4.11 Prefabricated fence

A concrete foundation ring, minimum of 300mm wide and 150mm deep shall be formed along the entire edge of the lunging area. The fence must be so manufactured that each element can be set into the concrete foundation ring at time of pouring the concrete. Under no circumstances can the fence simply be bolted to the concrete foundation ring. All fences shall be set down to a depth of 100mm into concrete ring.

10 Mechanical Walkers/Exercisers

10.1 Components of Walkers/Exercisers

Circular mechanical walkers may be installed with a minimum of four horse places and a maximum of eight. Walkers consist of (a) an enclosed outer circular track; (b) the central machinery together with moving arms which divide the track into sections; and (c) an optional roof over the track area.

The machinery and the dividing arms shall be of approved proprietary manufacture, fixed to a concrete plinth to manufacturer's specification. Other elements may also be of proprietary manufacture, or may be constructed on site. For safety reasons it is recommended that walkers are not constructed adjacent to exercise areas. It is also recommended that the site is accessible and is not located near main traffic routes in the farmyard. All horse walkers shall be equipped with a dead stop break for safe loading and unloading.

10.2 Outer Track

The dimensions of the track will normally be dictated by the chosen machinery and the dividing arms, but it shall be a minimum of 1.6m wide and a maximum of 2.4m.

The floor of the track may be of 125mm concrete, on 150mm hardcore, with a permanent covering of vulcanised rubber tiles, wood chips (minimum of 150mm depth), or equivalent material accepted by the Department. An all-weather surface (as per section 8) may also be installed. A plain concrete floor is not accepted.

If the track is unroofed, it shall be sloped to the inner edge to prevent ponding, and adequate drainage shall be provided from the central area to the outside.

The minimum diameter for walkers shall be 9.15m (30ft).

10.3 Walls

Walls may be constructed of solid concrete blocks with reinforcing pillars; or of timber within galvanised steel frames; or of heavy duty galvanised mesh within a galvanised framework. All walls shall be lined internally with min. 6mm reinforced rubber sheets or equivalent, to at least 1.2m from the floor. The outer wall shall be between 2.25 and 2.7m high; the inner wall between 1.75 and 2m. The portion of the walls above 1.2m may be constructed of galvanised steel mesh to allow for easy inspection of the horse walker.

A galvanised steel mesh gate, or timber gate with steel frame, shall be installed, 1.4 – 1.8m wide. The electric control panel(s) adjacent to the gate shall be protected from the weather. A 100mm diameter pipe (or two 50mm pipes) shall be installed well under the track to protect the power and control cables for the central machinery.

10.4 Roofs

It is recommended that no roof is constructed over the walker, but where installed, roofs shall be supported on galvanised steel stanchions set either within the outer wall or just outside it. Steel rafters shall be cantilevered from the stanchions, and suitably braced. Rafters should extend about 1m beyond the line of the inner wall. Cladding sheets shall be positioned on purlins fixed to the rafters. All metal cladding fixed to timber rails or purlins shall be separated by a layer of DPC. The eaves level shall be a minimum of 2.7m from floor level and the air space between the wall and eaves shall be unobstructed.

However, it is allowable to construct a barn structure over the walker but this is not recommended. In such cases the eaves shall be a minimum of 3m from floor level. There shall be a minimum of 1.5m unobstructed opening between the eave and the top of the wall. It is recommended that there are no walls in the barn structure. The barn structure shall be constructed in accordance with the Department of Agriculture, Food and the Marine specification S101.

The grant-aid payable on a barn structure over a walker is limited to payment on the area of roof equivalent to the walker. Grant aid is not payable on any wall in the barn structure.

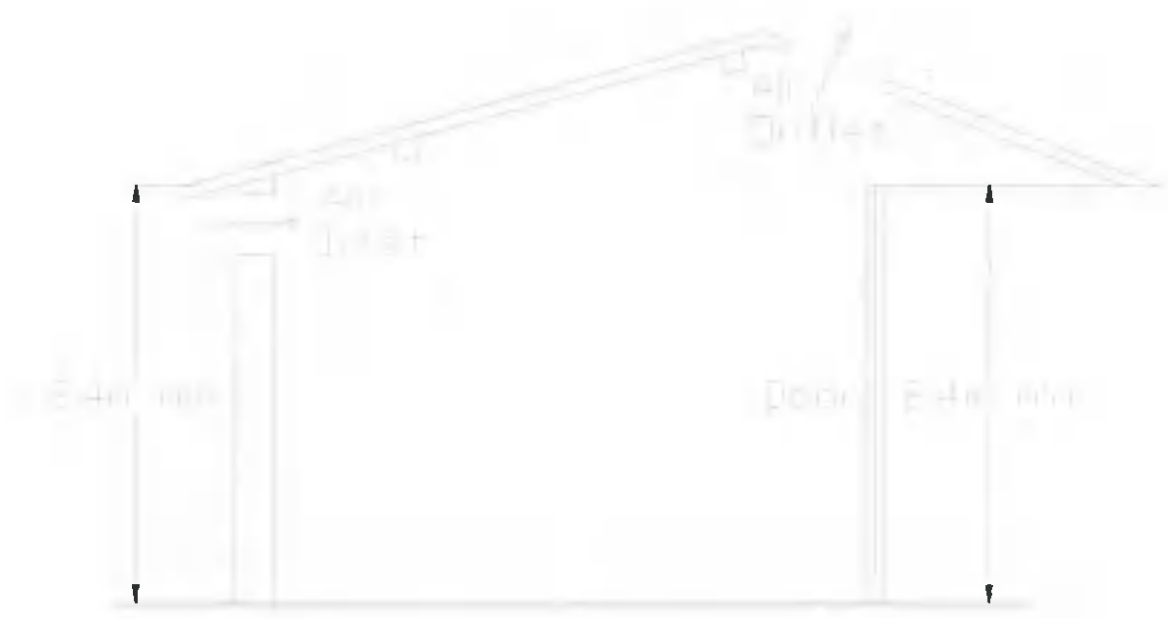
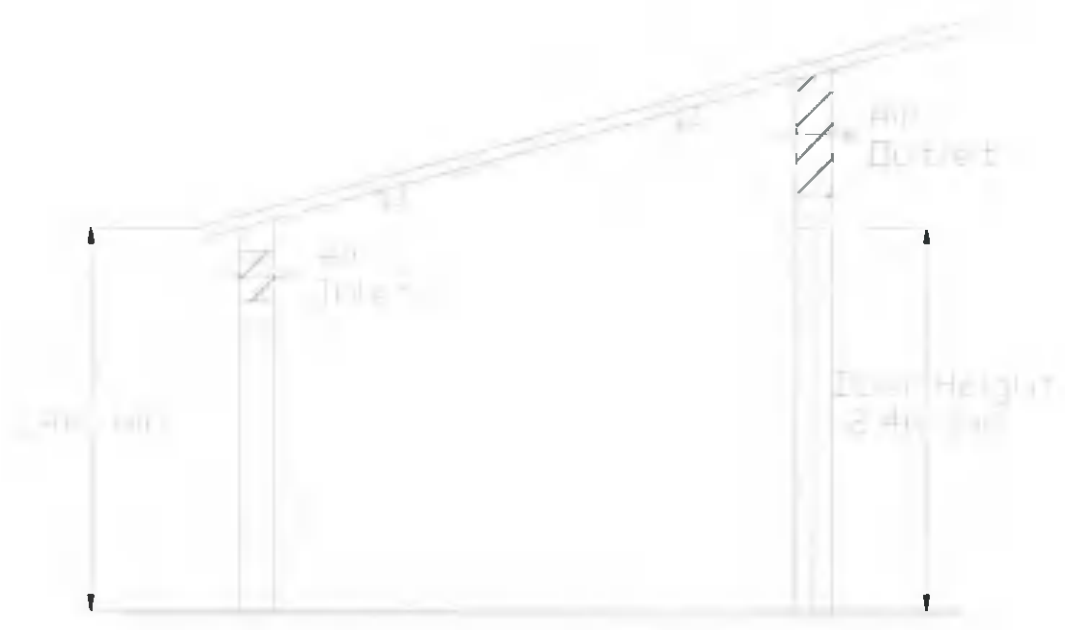

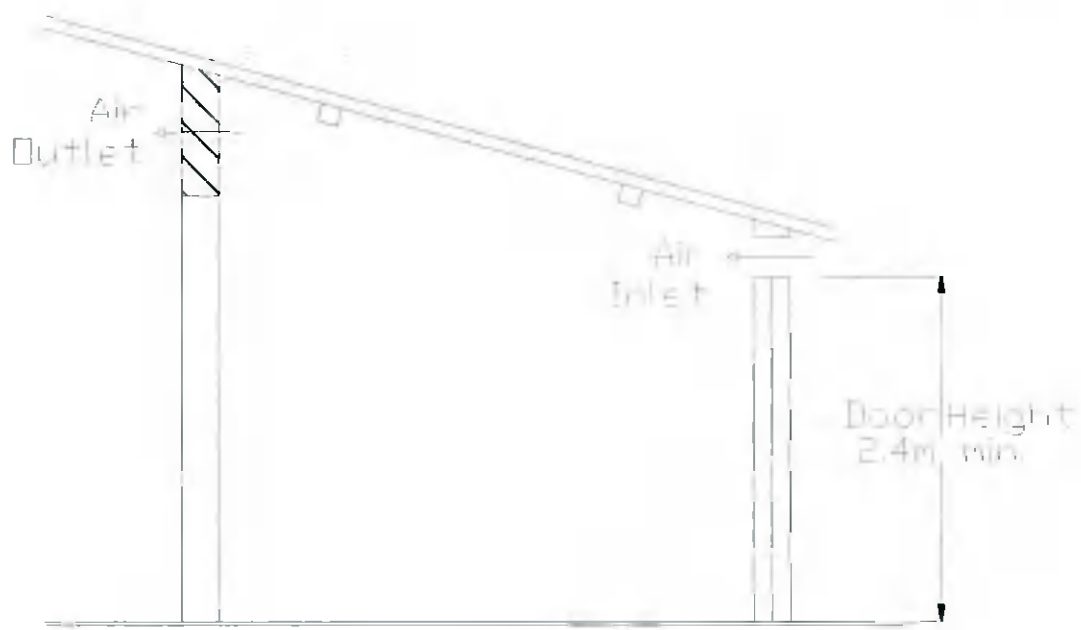

Figure 1 Cross-Sections of Typical Boxes

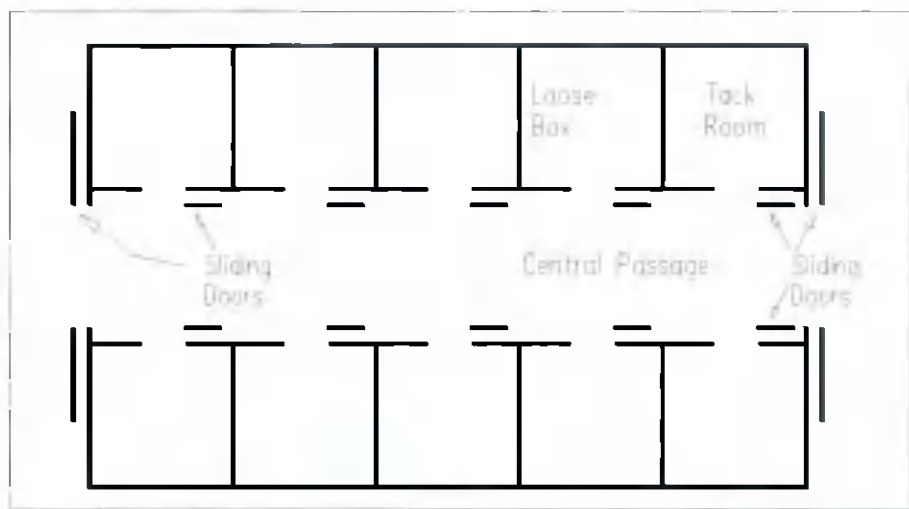

Figure 2 American Barn - Plan

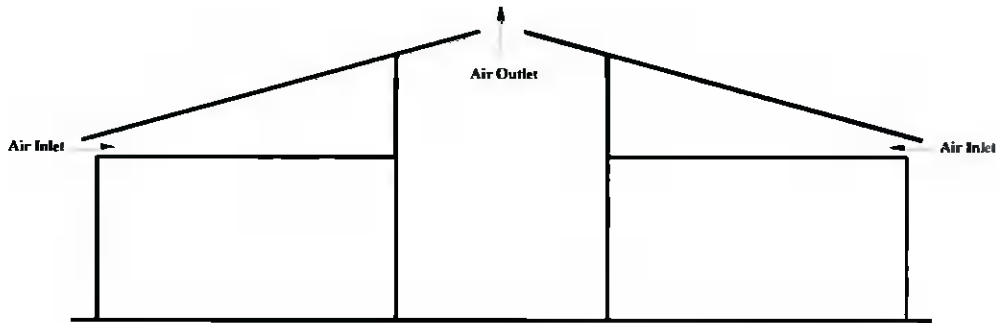

Figure 3 American Barn - Section

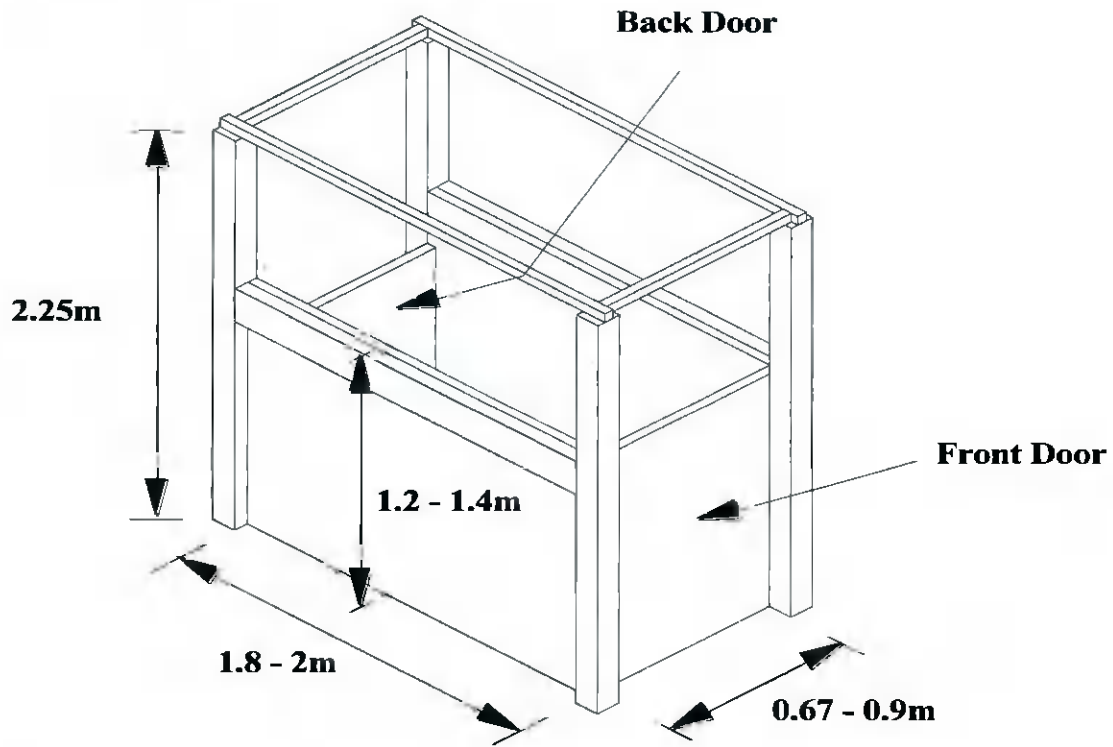

Figure Horse Stock

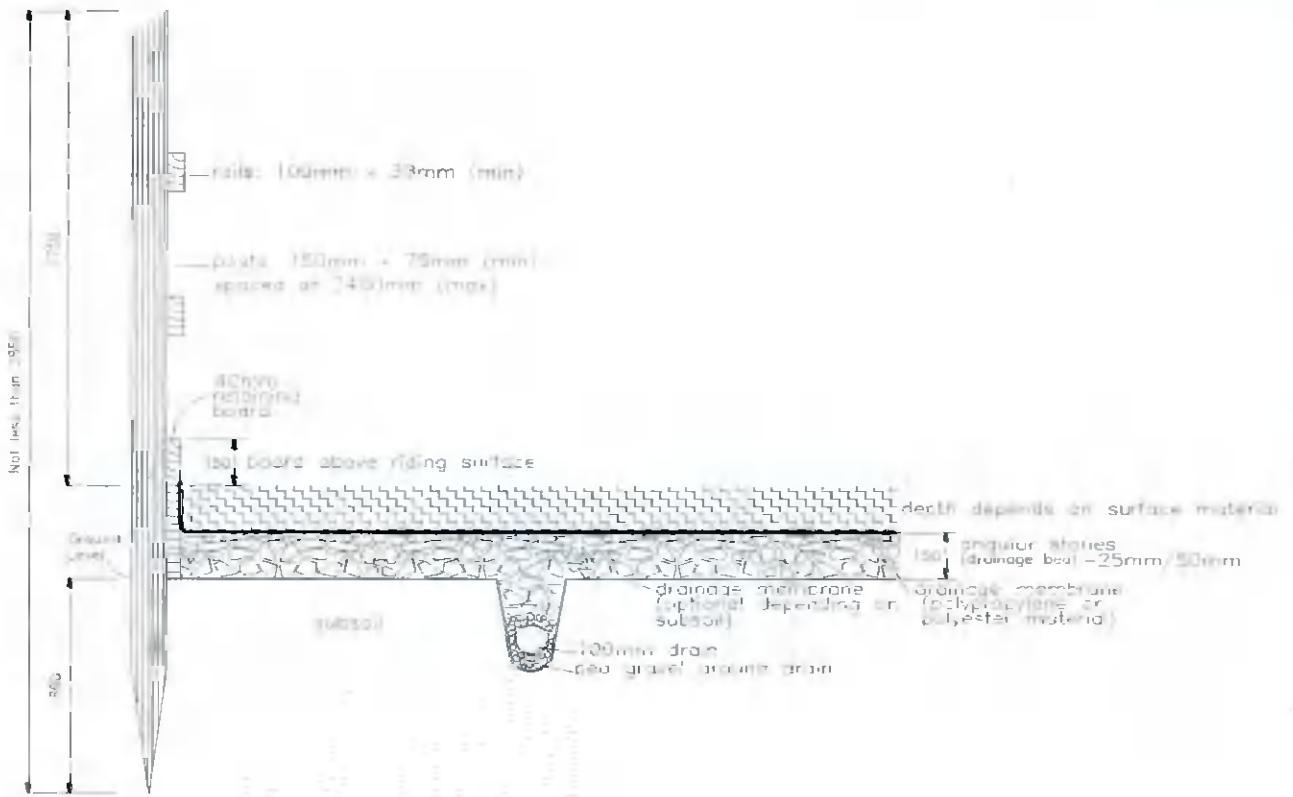

Figure 5 Lunging Ring (Section)

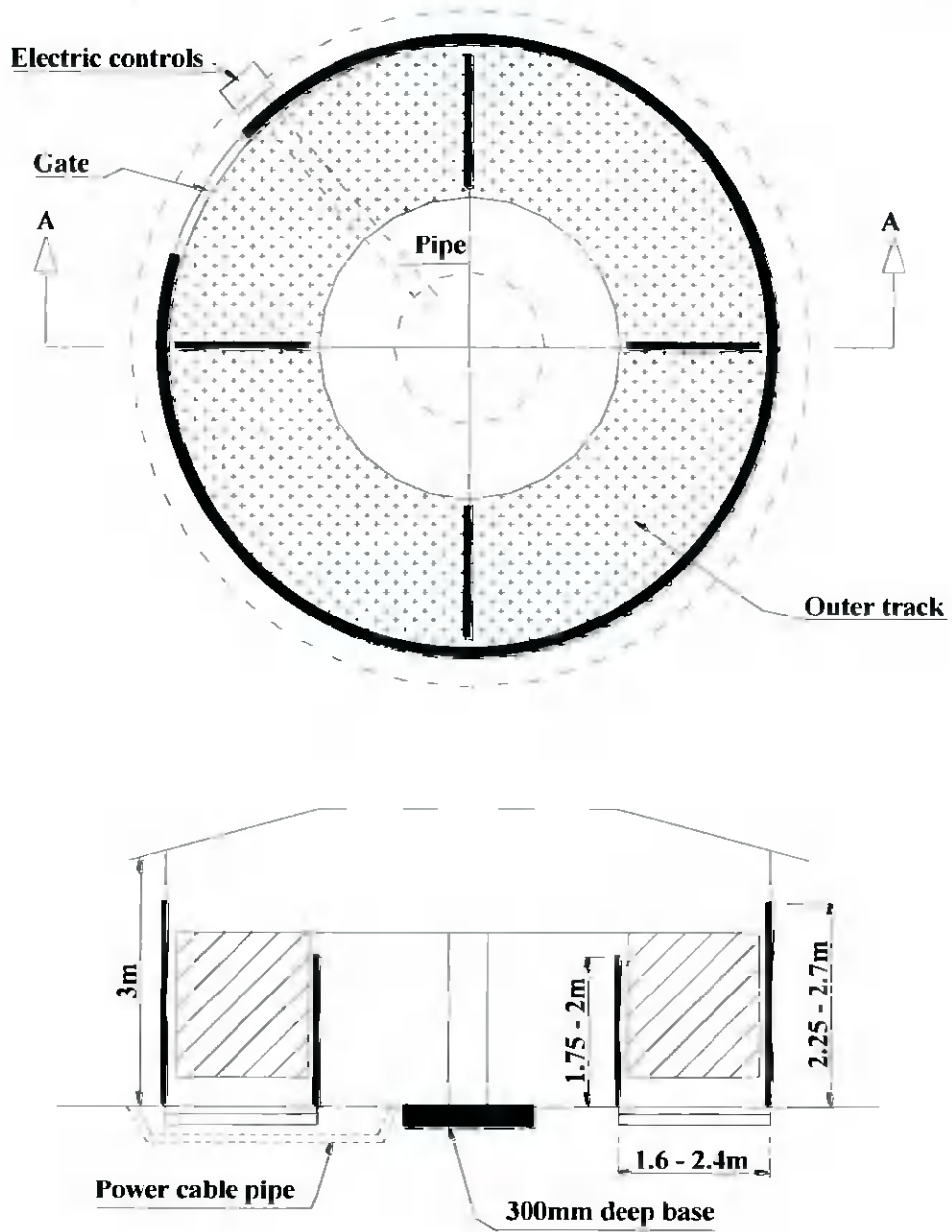

Figure 6 Walker