

PROJECT
 PROPOSED ALTERATIONS TO PERMITTED SHD ON LANDS AT PALMERSTOWN RETAIL PARK, KENNELSFORT ROAD LOWER, PALMERSTOWN, DUBLIN 20

CLIENT
 RANDELSWOOD HOLDINGS LTD.

CONSULTANT
 AECOM
 4th Floor Adelphi Plaza,
 George's Street Upper,
 Dun Laoghaire,
 Co Dublin
 Tel:+353 (0)1 2383100
 Fax:+353(0)1 2383199
 www.aecom.com

- NOTES**
1. THIS DRAWING IS TO BE READ IN CONJUNCTION WITH ALL OTHER RELEVANT ARCHITECTURAL AND ENGINEERING DRAWINGS. ANY DISCREPANCIES, ERRORS OR OMISSIONS TO BE BROUGHT TO THE ATTENTION OF THE DESIGNER.
 2. ALL DIMENSIONS TO BE CHECKED BY THE CONTRACTOR ON SITE PRIOR TO COMMENCEMENT OF WORKS.
 3. AECOM LIMITED TO BE INFORMED BY THE CONTRACTOR OF ANY DISCREPANCIES PRIOR TO THE COMMENCEMENT OF WORKS ON SITE.
 4. DIMENSIONS OF ALL BOUNDARIES AND ADJOINING ROADS TO BE CHECKED ON SITE PRIOR TO COMMENCEMENT OF WORKS.
 5. DO NOT SCALE. ALL MEASUREMENTS AND COORDINATES TO BE CHECKED ON SITE.

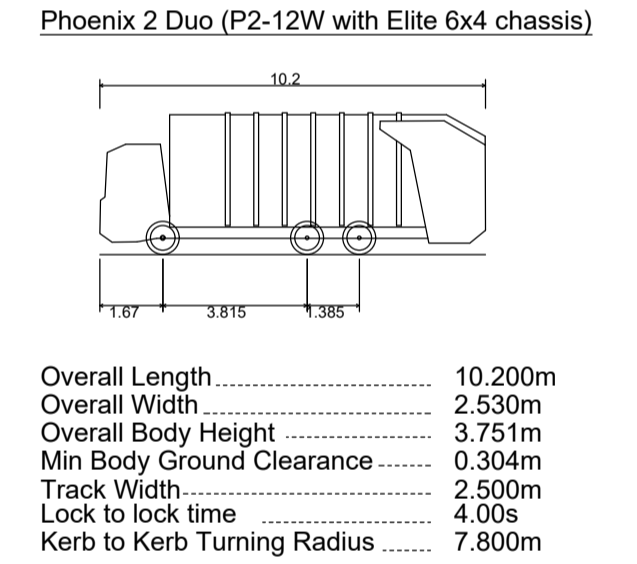

ISSUE/REVISION

I/R	DATE	DESCRIPTION
0	28.10.2021	ISSUED FOR PLANNING

PROJECT NUMBER
 60556657

SHEET TITLE
 PROPOSED SWEEP PATH ANALYSIS WITH EXISTING ROAD LAYOUT

SHEET NUMBER
 PAM-ACM-XX-00-DR-CE-01-0007

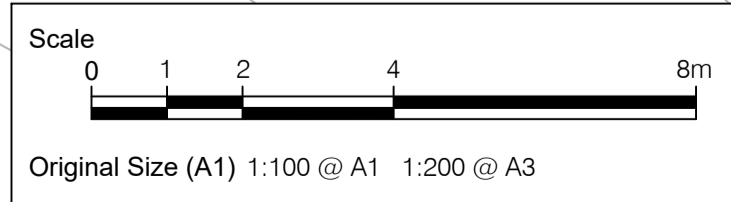

This drawing has been prepared for the use of AECOM's client. It may not be used, modified, reproduced or relied upon by third parties, except as agreed by AECOM, or as required by law. AECOM accepts no responsibility, and denies any liability, whatsoever, to any party that uses or relies on this drawing without AECOM's express written consent. Do not scale this document. All measurements must be obtained from the stated dimensions.