



**PROJECT**  
 PROPOSED ALTERATIONS TO PERMITTED SHD ON LANDS AT PALMERSTOWN RETAIL PARK, KENNELSFORT ROAD LOWER, PALMERSTOWN, DUBLIN 20

**CLIENT**  
 RANDELSWOOD HOLDINGS LTD.

**CONSULTANT**  
 AECOM  
 4th Floor Adelphi Plaza,  
 George's Street Upper,  
 Dun Laoghaire,  
 Co Dublin  
 Tel:+353 (0)1 2383100  
 Fax:+353(0)1 2383199  
 www.aecom.com

- NOTES**
1. THIS DRAWING IS TO BE READ IN CONJUNCTION WITH ALL OTHER RELEVANT ARCHITECTURAL AND ENGINEERING DRAWINGS. ANY DISCREPANCIES, ERRORS OR OMISSIONS TO BE BROUGHT TO THE ATTENTION OF THE DESIGNER.
  2. ALL DIMENSIONS TO BE CHECKED BY THE CONTRACTOR ON SITE PRIOR TO COMMENCEMENT OF WORKS.
  3. AECOM LIMITED TO BE INFORMED BY THE CONTRACTOR OF ANY DISCREPANCIES PRIOR TO THE COMMENCEMENT OF WORKS ON SITE.
  4. DIMENSIONS OF ALL BOUNDARIES AND ADJOINING ROADS TO BE CHECKED ON SITE PRIOR TO COMMENCEMENT OF WORKS.
  5. DO NOT SCALE. ALL MEASUREMENTS AND COORDINATES TO BE CHECKED ON SITE.

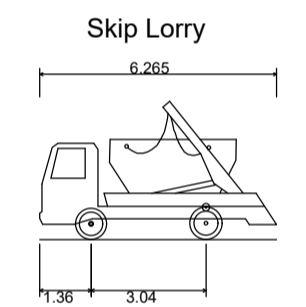

Overall Length	6.265m
Overall Width	2.500m
Overall Body Height	3.650m
Min Body Ground Clearance	0.396m
Max Track Width	2.435m
Lock to Lock Time	6.00 sec
Kerb to Kerb Turning Radius	6.340m



**ISSUE/REVISION**

I/R	DATE	DESCRIPTION
0	28.10.2021	ISSUED FOR PLANNING

**PROJECT NUMBER**  
60556657

**SHEET TITLE**  
PROPOSED SWEEP PATH ANALYSIS - SKIP LORRY

**SHEET NUMBER**  
PAM-ACM-XX-00-DR-CE-01-0003

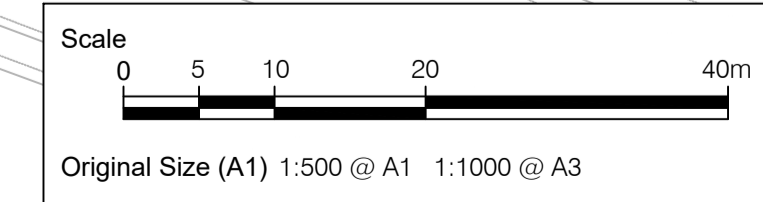

This drawing has been prepared for the use of AECOM's client. It may not be used, modified, reproduced or relied upon by third parties, except as agreed by AECOM or as required by law. AECOM accepts no responsibility, and denies any liability, whatsoever, to any party that uses or relies on this drawing without AECOM's express written consent. All measurements must be obtained from the stated dimensions.