

LEGEND

- LANDS OWNERSHIP BOUNDARY
- SID APPLICATION SITE BOUNDARY
- PROPOSED DEVELOPMENT
- PROPOSED EIRGRID SECURITY FENCE
- x PROPOSED EIRGRID POST & RAIL BOUNDARY FENCE
- PROPOSED BITUMINOUS ROAD SURFACE
- PROPOSED STONE SURFACE
- PROPOSED CONCRETE FOOTPATH
- PROPOSED SW ATTENUATION CONCRETE TANK
- PROPOSED MV CHAMBERS
- PROPOSED MARSHALLING KIOSKS
- PROPOSED EXTENT OF ASPHALT SURFACE
- PROPOSED LANDSCAPING
- EXISTING SURVEYED LEVELS
- 16.5m ARTIC VEHICLE FORWARD
- 16.5m ARTIC VEHICLE REVERSE

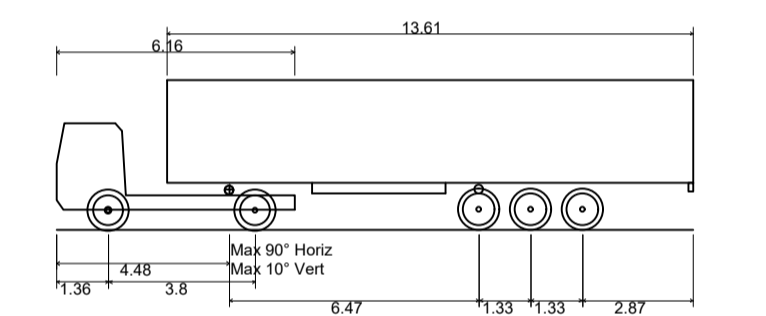

FTA Design Articulated Vehicle (2016)	16.480m
Overall Length	2.550m
Overall Width	3.870m
Overall Body Height	0.515m
Min Body Ground Clearance	2.470m
Max Track Width	3.00s
Lock-to-lock time	6.600m
Curb to Curb Turning Radius	

P04	SID ISSUE	DM	PM	04.02.2022
P03	DRAFT SID ISSUE	DM	PM	10.12.2021
P02	SID SCHEME ISSUE	DM	PM	26.11.2021
P01	WIP	DM	PM	22.10.2021

Clifton Scannell Emerson Associates Limited
 Consulting Engineers,
 3rd Floor The Heights,
 Bakers Point, Pottery Road,
 Dun Laoghaire, Co. Dublin,
 Ireland, A96 KW29

T: +353 1 288 5006
 F: +353 1 283 3466
 E: info@csea.ie
 W: www.csea.ie

VANTAGE DATA CENTERS

Client	KILCABERY 110KV SUBSTATION & MV CLIENT COMPOUND		
Project	PROPOSED 16.5M ARTIC HG V AUTOTRACKING		
Dwg. Title	21_115		
Drawn By	DM	Date	OCT 2021
Checked By	PM	Scale	AS INDICATED @ A1
Project Code	Originator	Zone/Phase	Level Type Role Dwg. No.
21_115 - CSE - 00 - XX - DR - C - 2106			
S2	PRELIMINARY		
P04	PRELIMINARY		

