

**Notes:**  
 All drawings are the copyright of the consultant (NIA Planning Consultants) and may not be used in whole or in part without the written consent of the consultant.  
 Do not scale from the drawing. Use written dimensions only.  
 All dimensions to be checked on site by the contractor and the consultant's method of surveying.  
 All levels indicated are approximate unless stated and do not relate to Ordnance Datum.  
 All levels to be checked and recorded with the 1007 Building Regulations with all subsequent revisions to same and with the requirements of the relevant local authority.

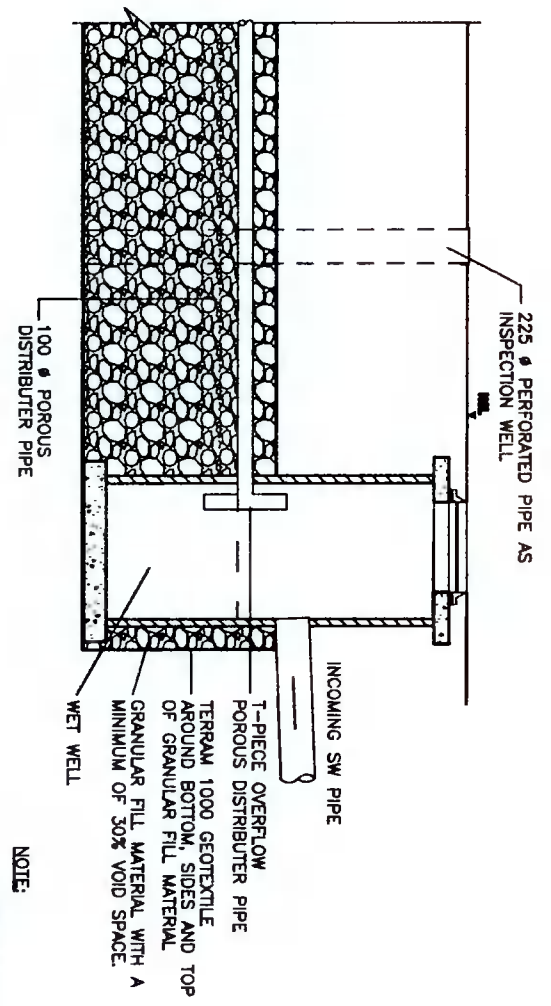

TYPICAL SECTION THRU SOAKAWAY

**NOTE:**  
 1. SOAKAWAYS SHOULD NOT BE CONSTRUCTED CLOSER THAN 5m TO BUILDING FOUNDATIONS.  
 2. DIMENSIONS OF PIT TO BE DETERMINED BY HYDRAULIC DESIGN IN ACCORDANCE WITH METHOD STATED IN BRE DIGEST 365.

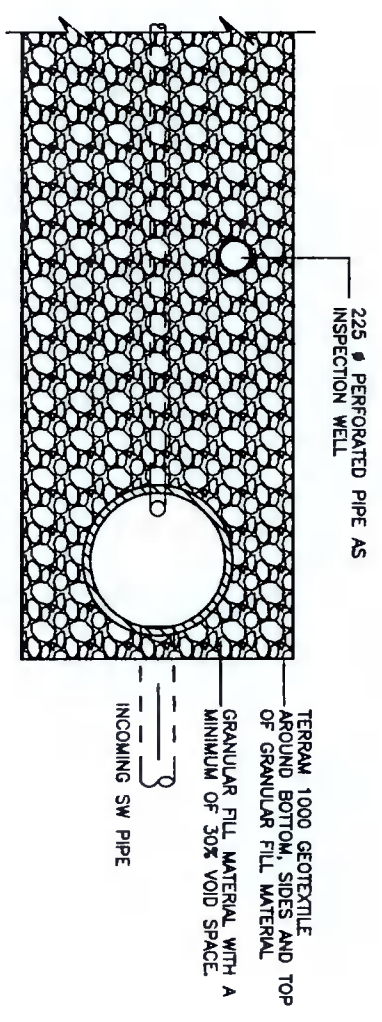

TYPICAL PLAN OF SOAKAWAY

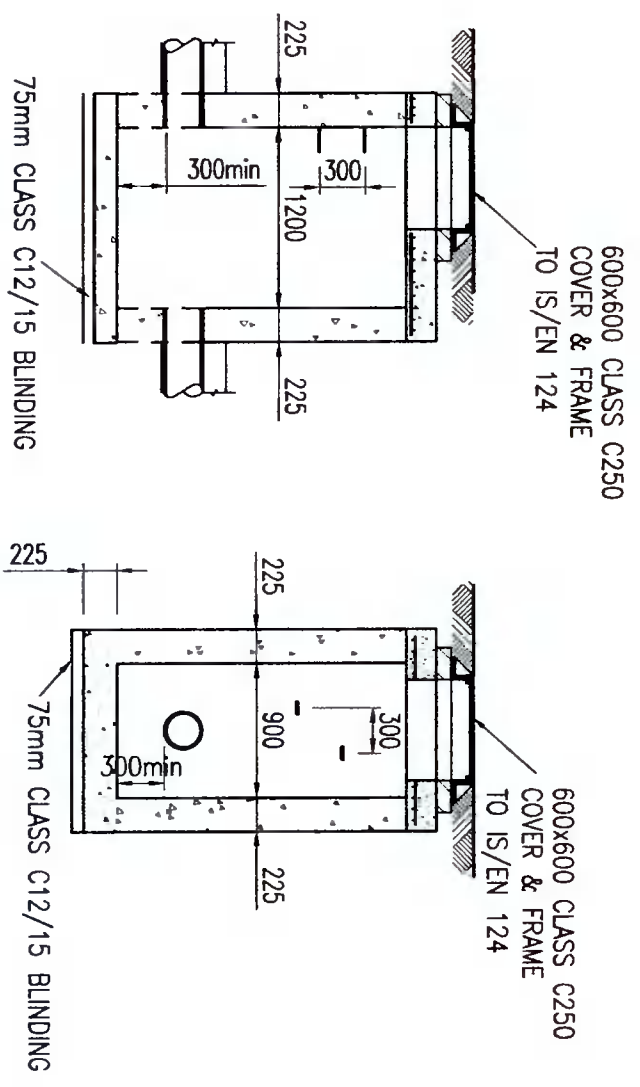

TYPICAL CATCHPIT MANHOLE

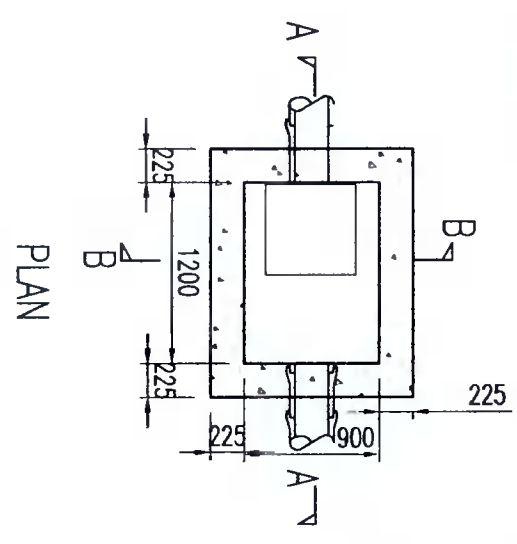

ADDITIONAL INFORMATION

REVISION	DATE	BY

**Niall Jones & Associates**  
 Planning Consultants

**PROPOSED EXTENSION & INTERNAL ALTERATIONS AT 69 BALLYROAN CRESCENT, RATHFARINHAM, DUBLIN 14 FOR MR FERGUS MCCABE**

**PLANNING DRAWING: PROPOSED SOAKAWAY & CATCHPIT MANHOLE DETAILS**

SCALE	DATE	DRAWN BY	CHECKED	JOB NO.	DRAWING NO.	REV.
1:50	JAN '22	N.Jones	N.J.	20/258	P.09	