

PROPOSED BICYCLE STATION 1

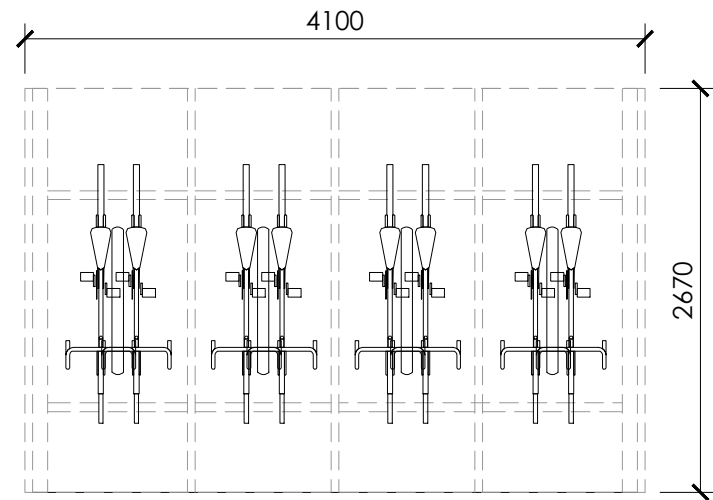

PROPOSED PLAN_STATION 1
1:50

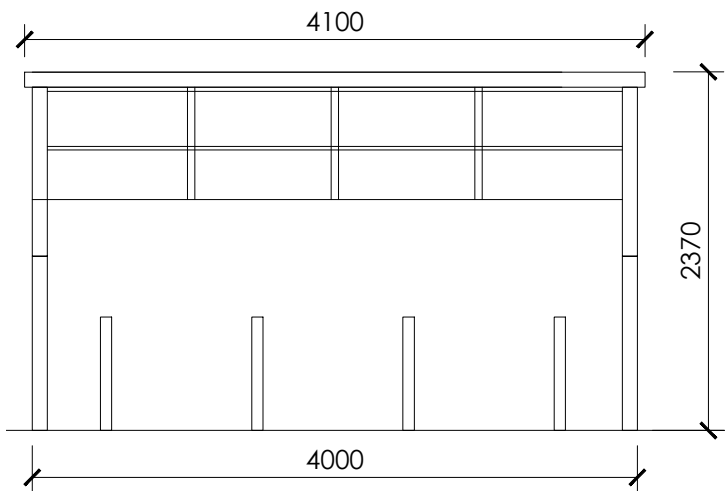

PROPOSED FRONT ELEVATION_STATION 1
1:50

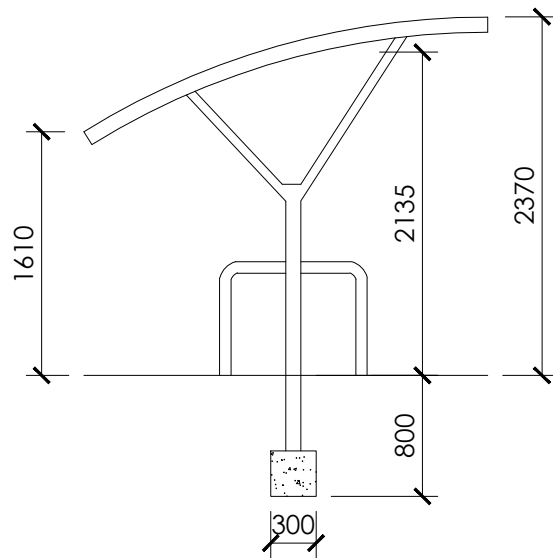

PROPOSED SIDE ELEVATION_STATION 1
1:50

PROPOSED BICYCLE STATION 2

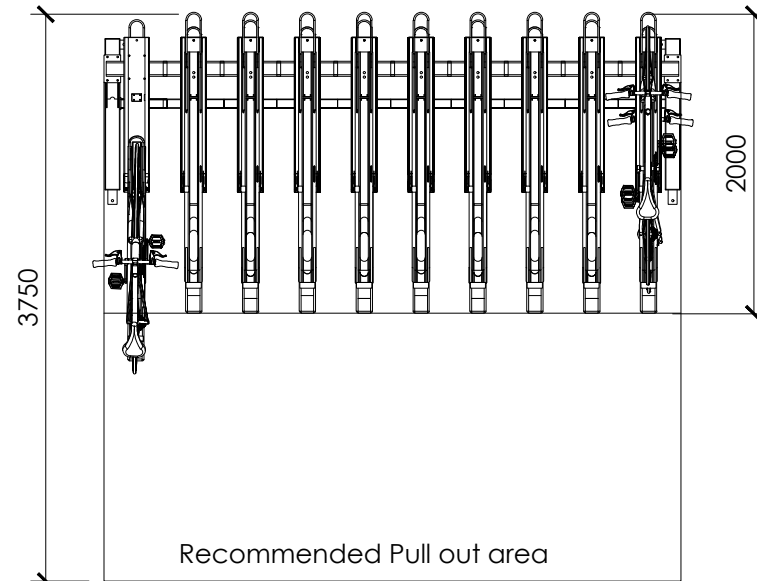

PROPOSED PLAN_STATION 2
1:50

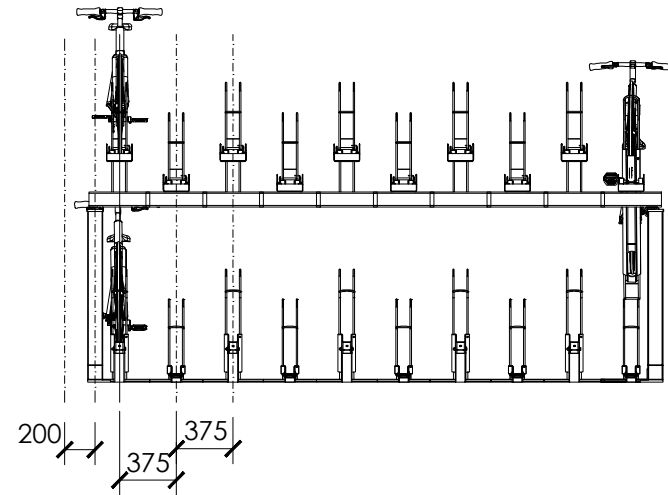

PROPOSED FRONT ELEVATION_STATION 2
1:50

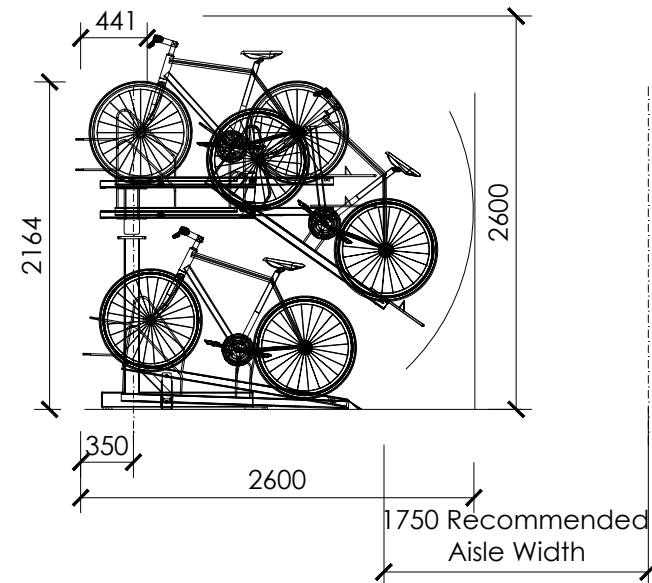

PROPOSED SIDE ELEVATION_STATION 2
1:50

PROPOSED BICYCLE STATION 3

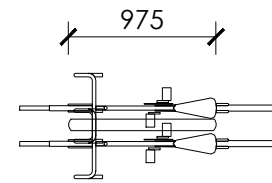

PROPOSED ELEVATION
STATION 3
1:50

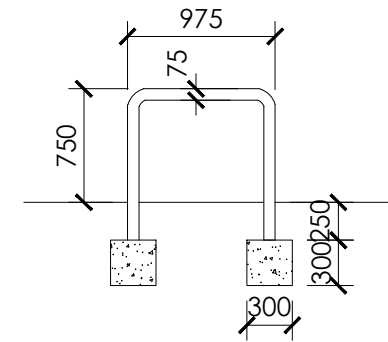

PROPOSED PLAN
STATION 3
1:50

GENERAL NOTES -
 ** Do not scale from this drawing
 ** Use figured dimensions only
 © This drawing is copyright. No part of this document may be re-produced or transmitted in any form or stored in any retrieval system from the copyright holder, except as agreed for used on a project, for which the document was originally issued.



KEY PLAN
NTS

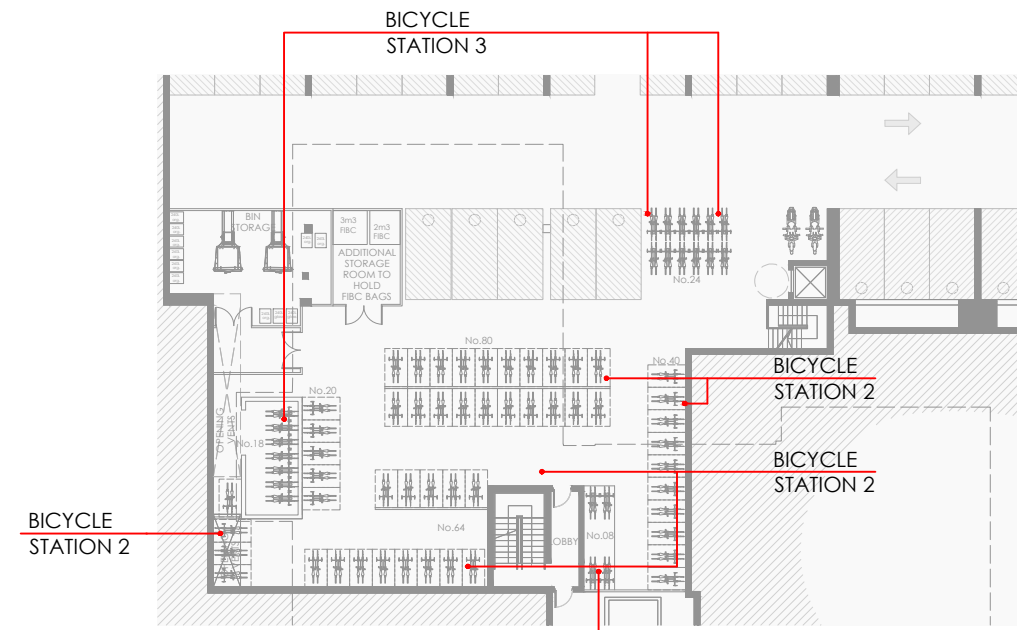

KEY PLAN
NTS

STAGE 3

ha
DESIGN STUDIO

36 Mount Street Upper, Dublin D02 Y982
+353 1 524 0709 www.hads.ie

CLIENT
RANDELSWOOD HOLDINGS LTD.
PROJECT
PROPOSED SHD DEVELOPMENT AT
DOLCAIN HOUSE, MONASTERY RD.
CLONDALKIN, DUBLIN 22

DWG. TITLE
PROPOSED BICYCLE STATIONS

SCALE @ A3: 1:50
 DRAWN BY: KT
 CHECKED BY: JH
 PAPER SIZE: A3
 JOB NO. 18-001
 DATE: 11.01.2022

DWG. NO. PL-402