

NOTES:
 ALL TIMBERS TO BE SCB AND IN ACCORDANCE WITH SR 11 1991. PROVIDE LATERAL SUPPORT TO WALLS WHERE THEY RUN PARALLEL TO JOISTS, BY FIXING 30X6MM GALV. M.S. STRAPS AT 2M CRS ACROSS 2 NO JOISTS. SOLID NOGGING PIECES TO BE FIXED DIRECTLY UNDER STRAPS. DITTO ALONG ROOF SLOPE. INSULATION BETWEEN RAFTERS TO BUILDING REGULATIONS. PROVIDE 50MM UNOBSTRUCTED AIR SPACE BETWEEN INSULATION AND ROOF FELT. PROVIDE VENTILATION AT EAVES TO PROMOTE CROSS VENTILATION 10MM STRIP FULL LENGTH

FLOOR:
 FINISH 50mm SCREED ON 100mm CONCRETE FLOOR SLAB ON 50mm FLOOR INSULATION ON 1000 GAUGE POLYTHENE DPM TURNED UP AT EDGES ON 50mm SAND BLINDING ON 150mm MINIMUM CONSOLIDATED HARDCORE DPC MINIMUM 150mm ABOVE GROUND LEVEL SOLID BLOCKWORK BELOW DPC

SECTION VIEW SHOWING PROPOSED EXTENSION

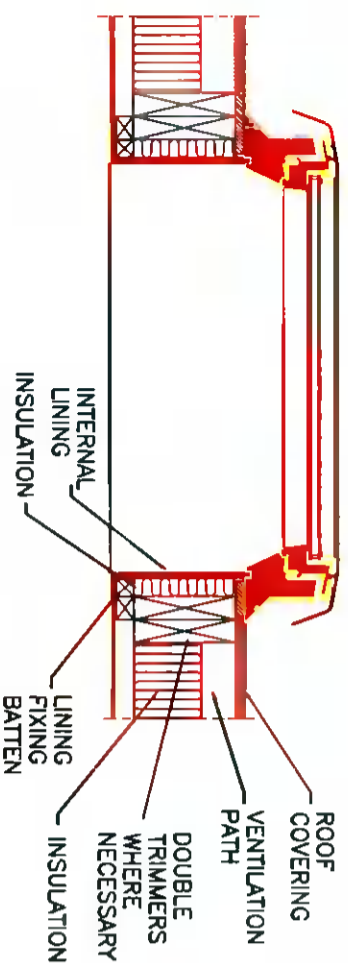

TYPICAL ROOF WINDOW DETAIL

255 HOLLOW CONCRETE BLOCK FINISHED AS PER EXISTING HOUSE. 90mm XTRATHERM THIN-R/TLMF (FOILBACKED) BONDED TO 12.5 PLASTERBOARD MECHANICALLY FIXED TO INNER FACE AND WITH 6mm PLASTER SKIN FINISH. PROVIDE GROUNDS AS INDICATED/REQUIRED

CONCRETE REINFORCED STRIP FOUNDATION 675 x 225 MINIMUM. DEPTH 900mm BELOW SURROUNDING GROUND LEVEL OR TO SOLID BEARING GROUND. (BASED ON SOLID FIRM SOIL CONDITIONS)

50mm FLOOR INSULATION ON 1000 GAUGE POLYTHENE DPM TURNED UP AT EDGES ON 50mm SAND BLINDING ON 150mm MINIMUM CONSOLIDATED HARDCORE DPC MINIMUM 150mm ABOVE GROUND LEVEL SOLID BLOCKWORK BELOW DPC



TYPICAL FOUNDATION DETAIL

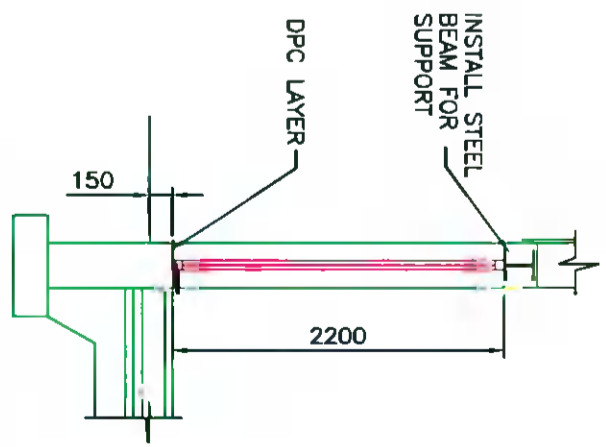

SLIDING DOOR DETAIL

The information contained in this drawing is confidential and must not be divulged to any third party without the written consent of Abes Design Services.



38 Larkfield Avenue
 Lucan
 Co. Dublin

24 St Anthony's Crescent,
 Greenhills, Dublin 12,
 D12 N8P2

PROPOSED SECTIONS AND
 DETAILS

DRAWN	JOHN FORBES , 38 LARKFIELD AVE. , LUCAN, CO. DUBLIN
DATE	Sept 2021
SCALE	1:50 @ A3
Sean O'Connor and Georgina Leonard	
AC - 12	