



PROJECT
PROPOSED STRATEGIC HOUSING DEVELOPMENT AT STOCKING LANE, BALLYBODEN, DUBLIN 16

CLIENT
MacCABE DURNEY BARNES

CONSULTANT
AECOM
4th Floor Adelphi Plaza,
George's Street Upper,
Dun Laoghaire,
Co Dublin
Tel: +353 (0)1 2383100
Fax: +353(0)1 2383199
www.aecom.com

- NOTES**
- THIS DRAWING IS TO BE READ IN CONJUNCTION WITH ALL OTHER RELEVANT ARCHITECTURAL AND ENGINEERING DRAWINGS. ANY DISCREPANCIES, ERRORS OR OMISSIONS TO BE BROUGHT TO THE ATTENTION OF THE DESIGNER.
 - ALL DIMENSIONS TO BE CHECKED BY THE CONTRACTOR ON SITE PRIOR TO COMMENCEMENT OF WORKS.
 - AECOM LIMITED TO BE INFORMED BY THE CONTRACTOR OF ANY DISCREPANCIES PRIOR TO THE COMMENCEMENT OF WORKS ON SITE.
 - DIMENSIONS OF ALL BOUNDARIES AND ADJOINING ROADS TO BE CHECKED ON SITE PRIOR TO COMMENCEMENT OF WORKS.



LEGEND

 SWEEP PATH FORWARDS MOVEMENT
 SWEEP PATH BACKWARDS MOVEMENT

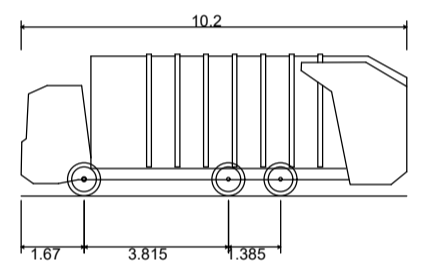
Phoenix 2 Duo (P2-12W with Elite 6x4 chassis)

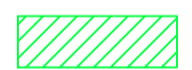

Overall Length 10.200m
 Overall Width 2.530m
 Overall Body Height 3.751m
 Min Body Ground Clearance 0.304m
 Track Width 2.500m
 Lock to lock time 4.00s
 Kerb to Kerb Turning Radius 7.800m

 SWEEP PATH FORWARDS MOVEMENT
 SWEEP PATH BACKWARDS MOVEMENT

Dennis Sabre Fire Tender (LWB)

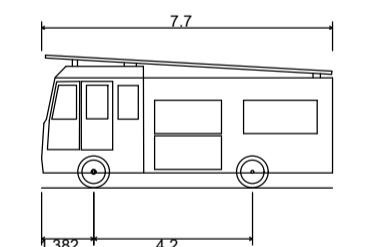

Overall Length 7.700m
 Overall Width 2.430m
 Overall Body Height 3.512m
 Min Body Ground Clearance 0.397m
 Track Width 2.380m
 Lock to Lock Time 5.00 sec
 Kerb to Kerb Turning Radius 7.400m

ISSUE/REVISION

NO	DATE	DESCRIPTION
C	28.09.2021	STAGE 3 ISSUE TO ABP
B	14.09.2021	DRAFT ISSUE
A	10.09.2021	DRAFT ISSUE
I/R	DATE	DESCRIPTION

PROJECT NUMBER
60599961

SHEET TITLE
AUTOTRACK ANALYSIS

SHEET NUMBER
PR402491-ACM-01-00-DR-CE-10-0102



This drawing has been prepared for the use of AECOM's client. It may not be used, modified, reproduced or relied upon by third parties, except as agreed by AECOM, or as required by law. AECOM accepts no responsibility, and denies any liability, whatsoever, to any party that uses or relies on this drawing without AECOM's express written consent. Do not scale this document. All measurements must be obtained from the stated dimensions.