

NOTES:  
 OBA CONSULTING CIVIL & STRUCTURAL ENGINEERS  
 HAS CONSIDERABLE EXPERIENCE AND IS THE SOLE PROPRIETOR OF THE  
 CONSULTANTS AND MUST NOT BE REPRODUCED WITHOUT THEIR WRITTEN  
 CONSENT.

ALL DRAWINGS REMAIN THE PROPERTY OF THE CONSULTANTS.  
 FIGURED DIMENSIONS ONLY TO BE TAKEN FROM THIS DRAWING.  
 DO NOT SCALE  
 ALL DIMENSIONS TO BE CHECKED ON SITE.  
 CONSULTANTS TO BE INFORMED OF ANY DISCREPANCIES BEFORE WORK  
 COMMENCES  
 GENERAL NOTE:  
 CELLULAR ROOT PROTECTION TO BE USED IN ACCORDANCE WITH THE  
 MANUFACTURERS RECOMMENDATIONS AND TO BE INSTALLED PRIOR  
 TO CONSTRUCTION FOR THE PROTECTION OF TREES LOCATED IN CLOSE  
 PROXIMITY TO PROPOSED EXCAVATIONS.

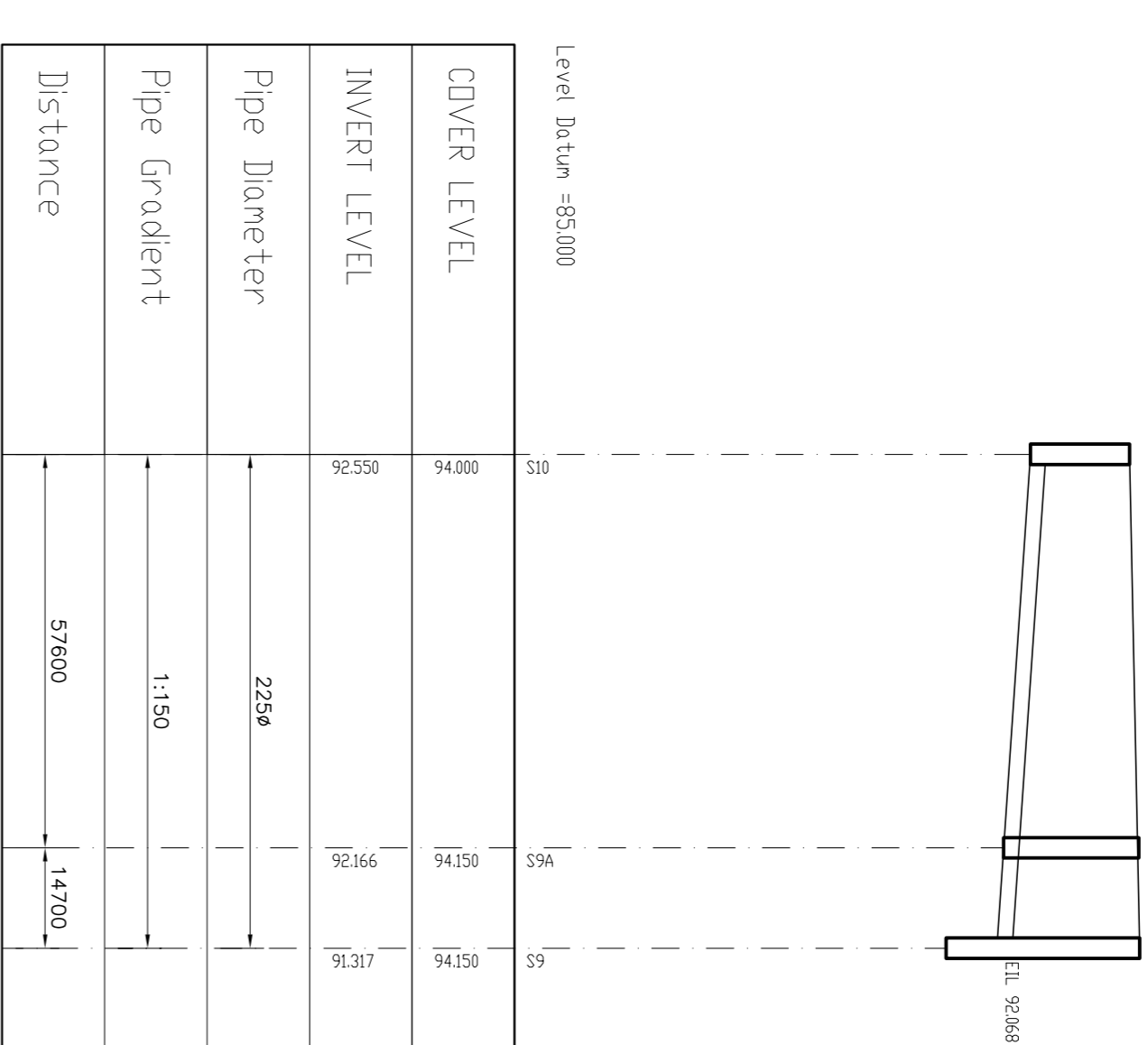
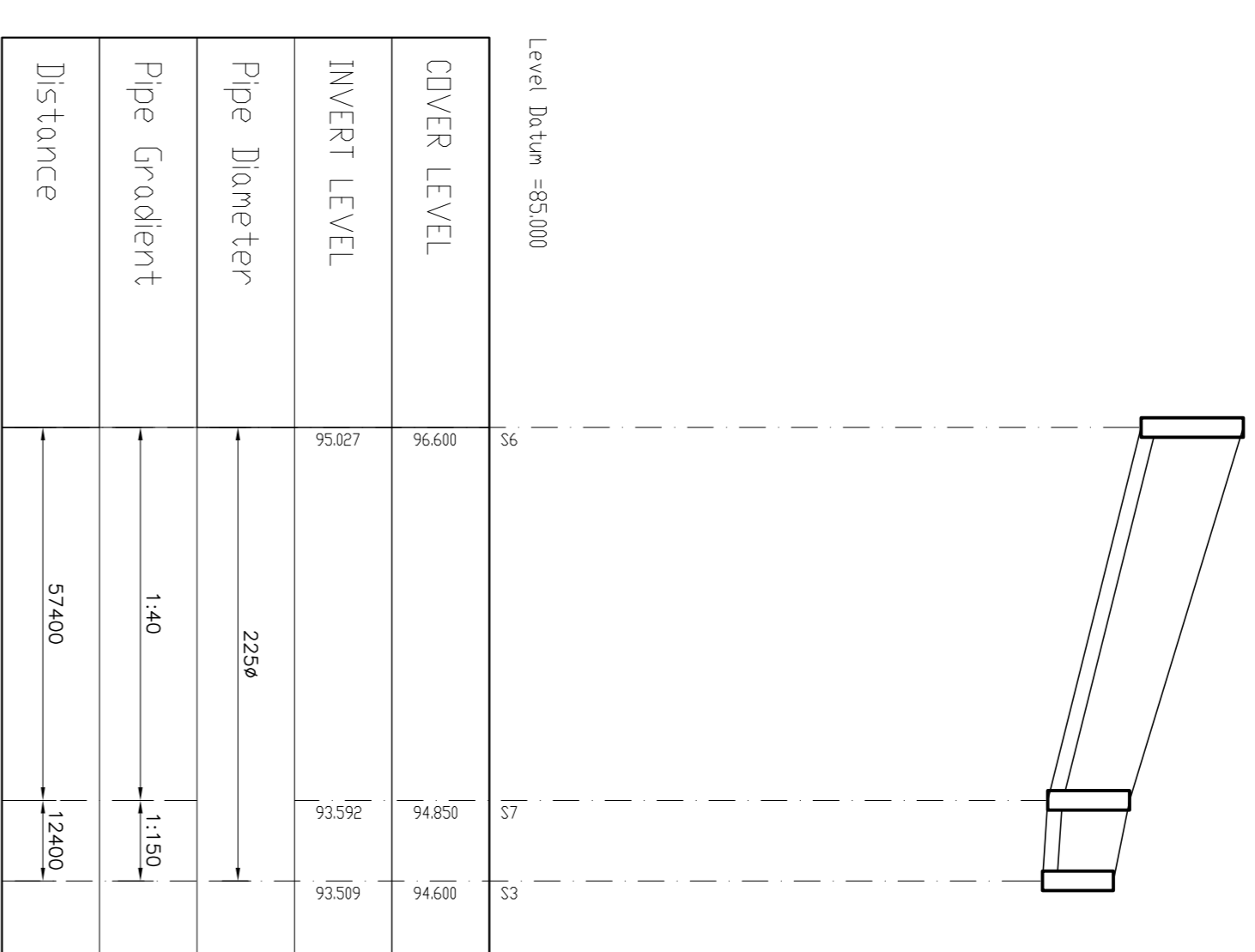
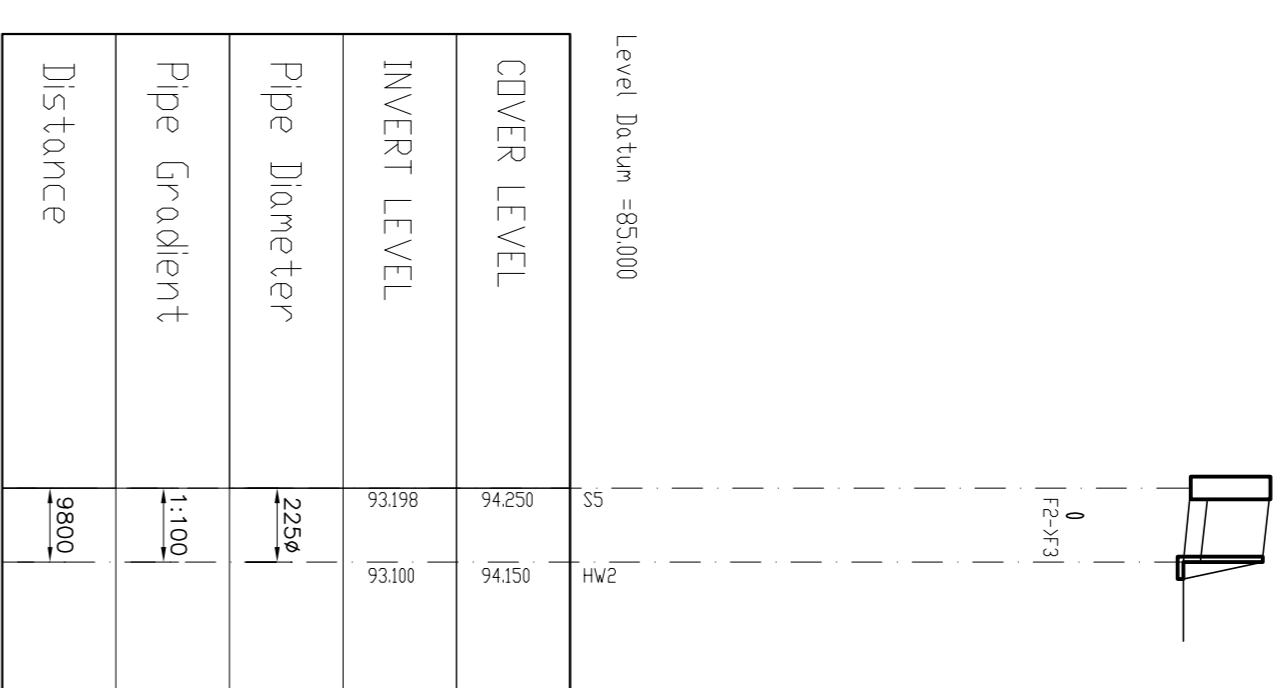
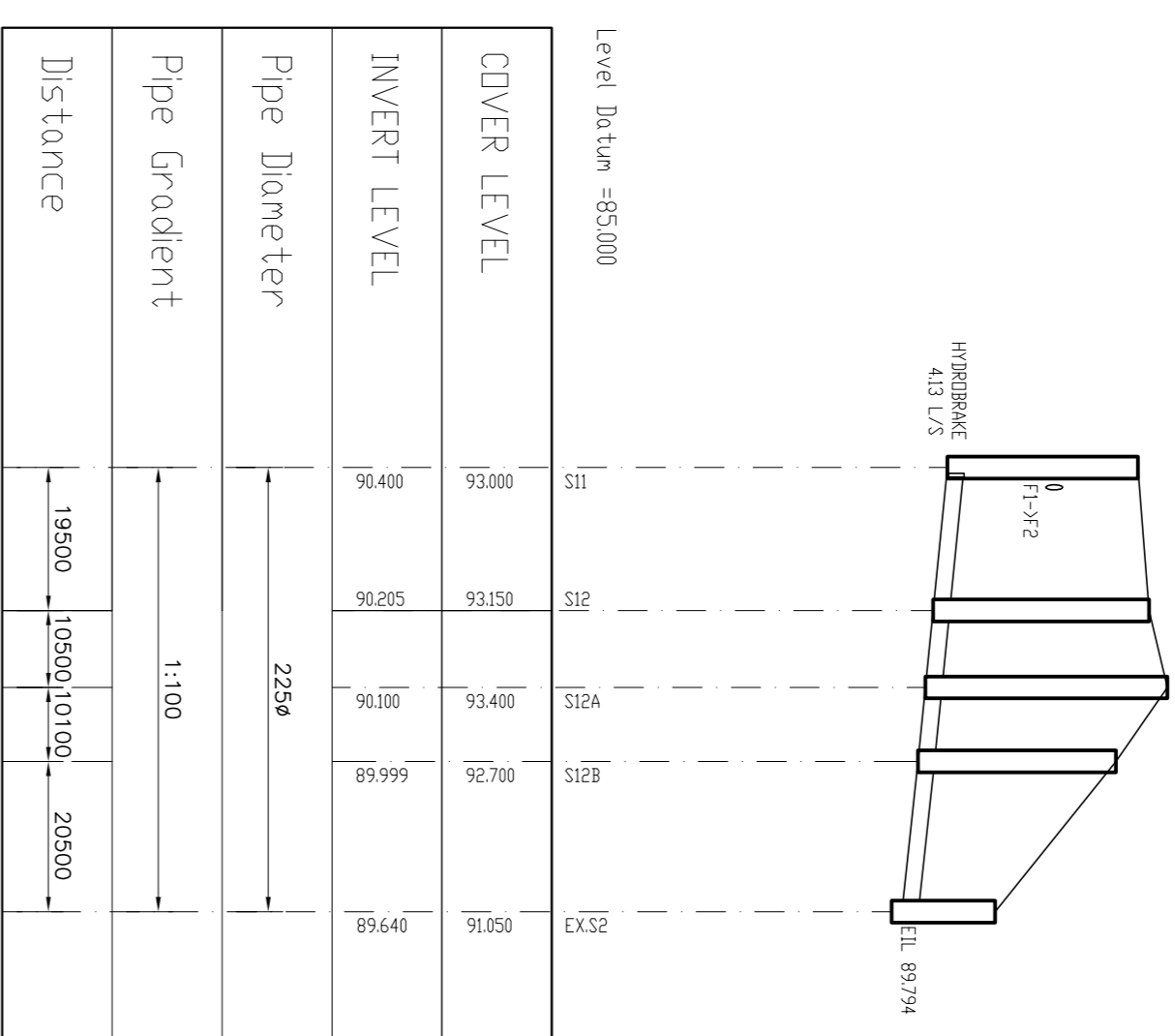
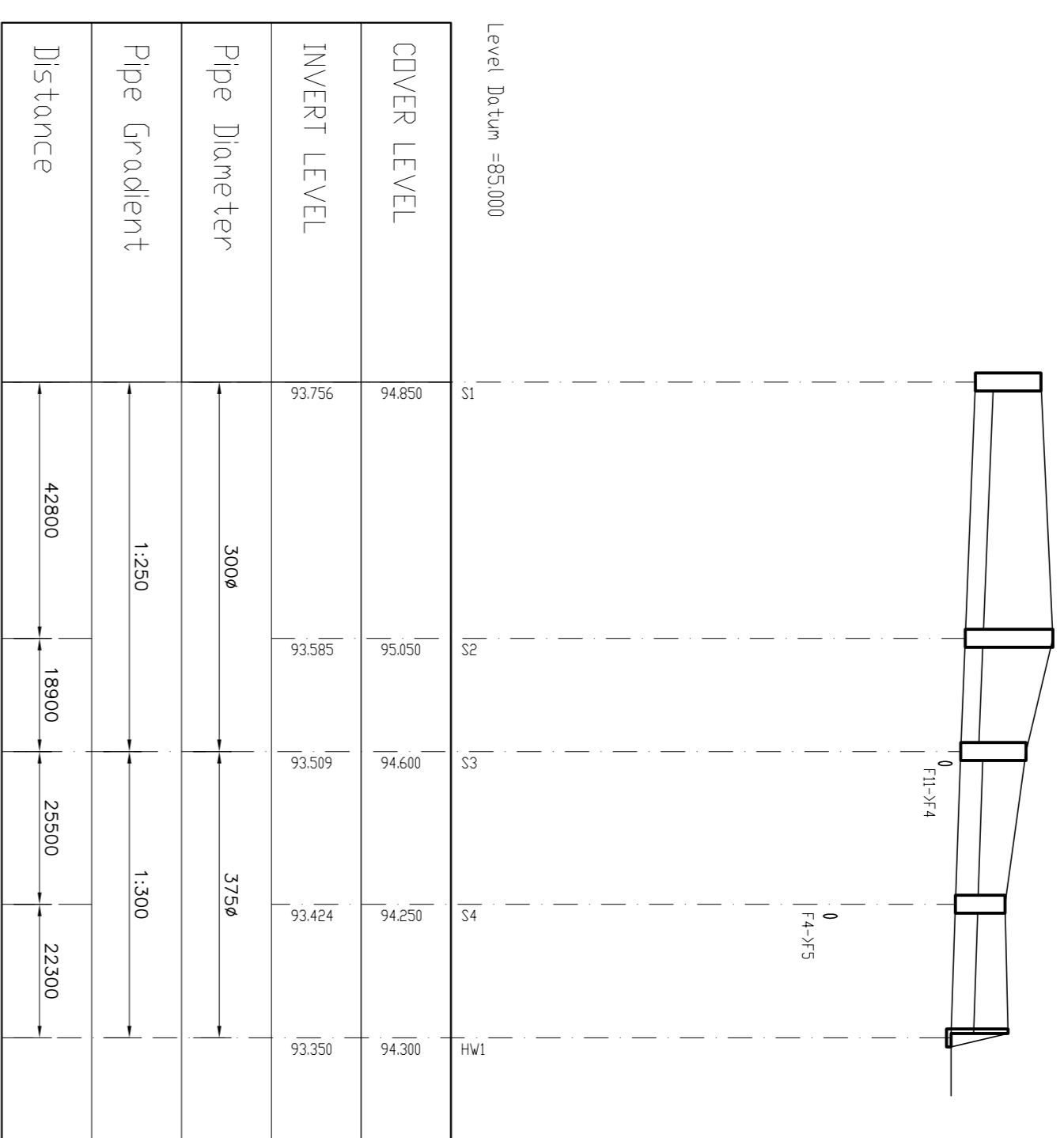

SW LONGITUDINAL SECTION  
 S1 TD HW1

HORIZONTAL SCALE 1:1000  
 VERTICAL SCALE 1:100

SW LONGITUDINAL SECTION  
 S11 TD EX,S2

HORIZONTAL SCALE 1:1000  
 VERTICAL SCALE 1:100

SW LONGITUDINAL SECTION  
 S5 TD HW2

HORIZONTAL SCALE 1:1000  
 VERTICAL SCALE 1:100

SW LONGITUDINAL SECTION  
 S6 TD S3

HORIZONTAL SCALE 1:1000  
 VERTICAL SCALE 1:100

SW LONGITUDINAL SECTION  
 S10 TD S9

HORIZONTAL SCALE 1:1000  
 VERTICAL SCALE 1:100

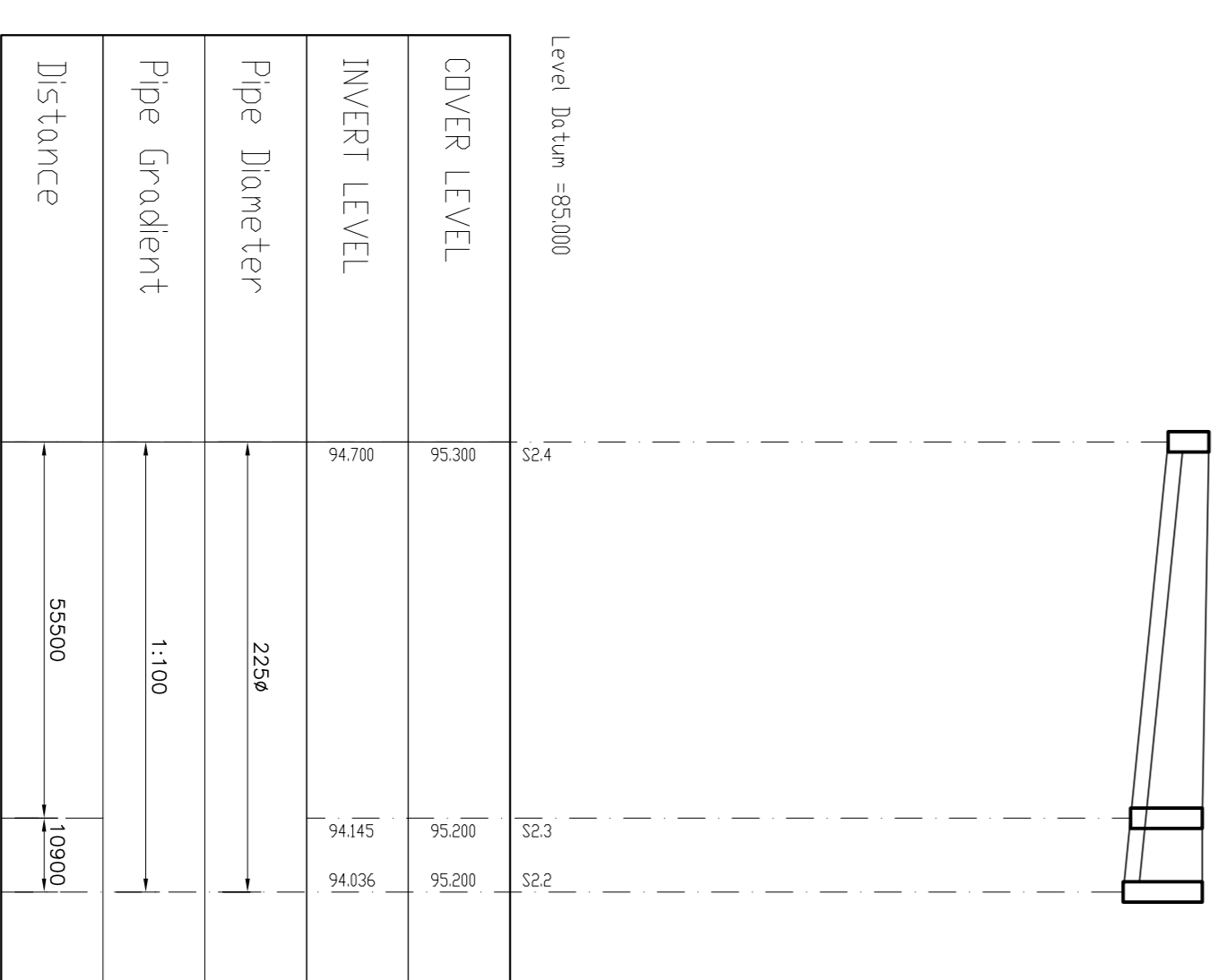
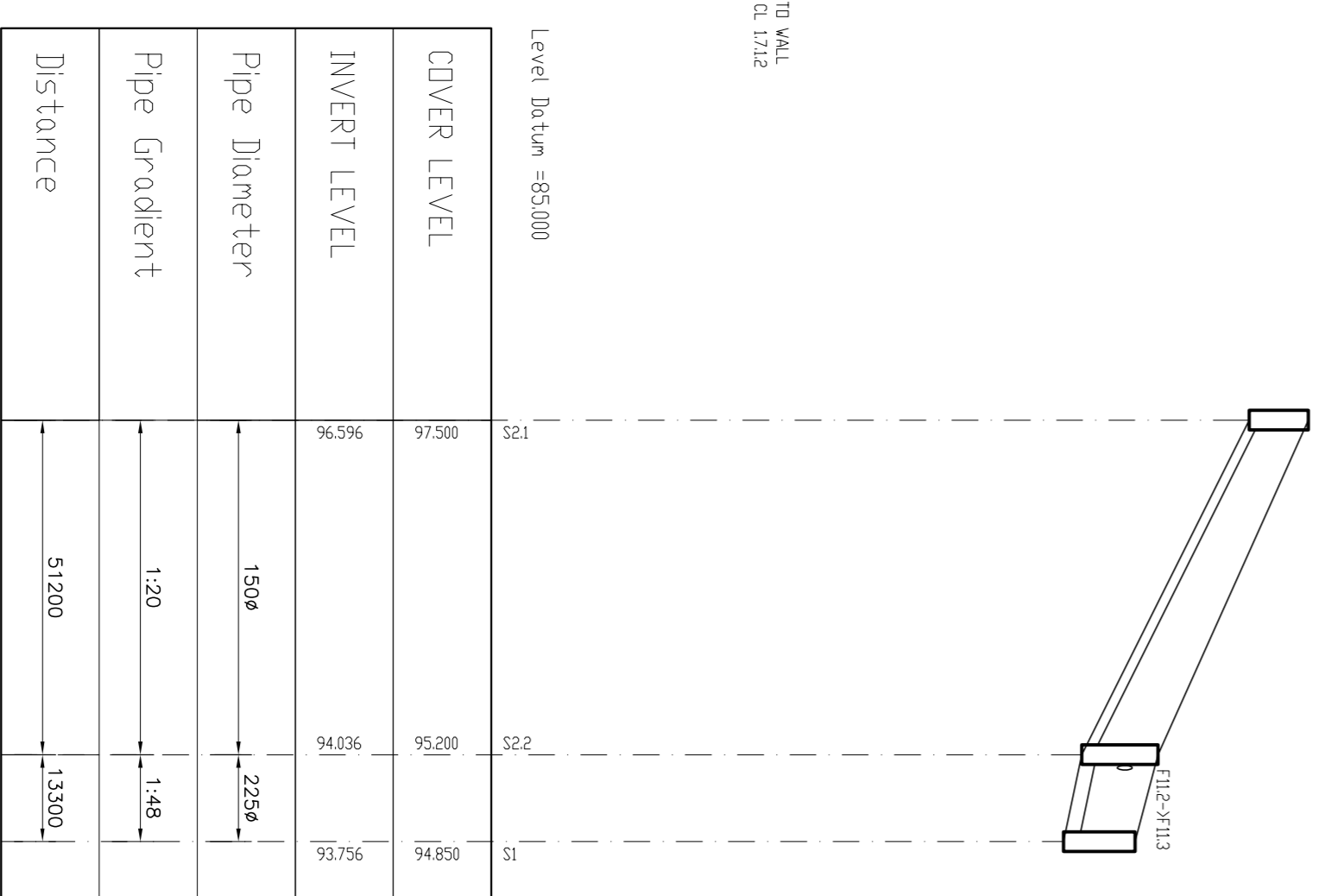
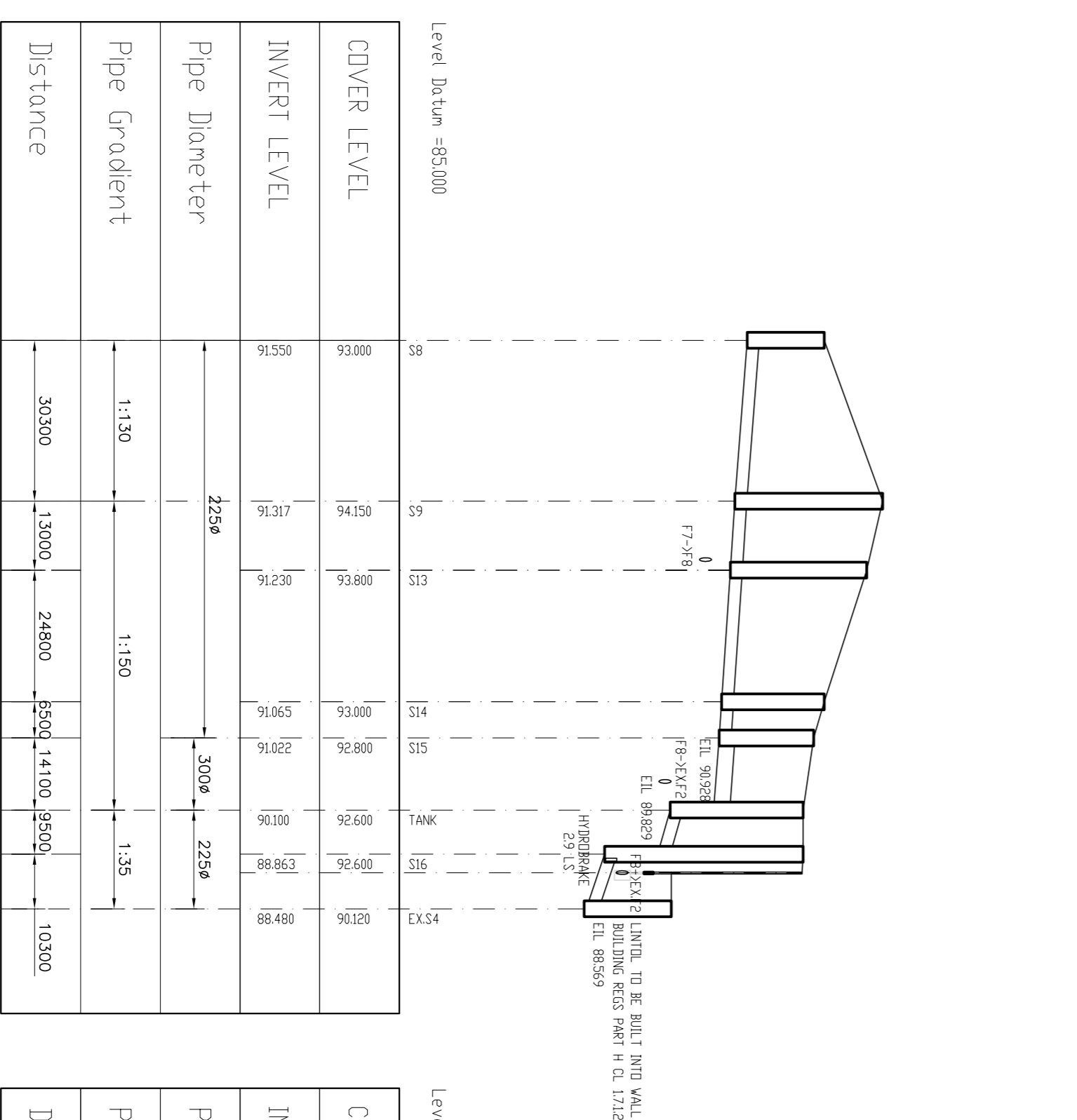

SW LONGITUDINAL SECTION  
 S8 TD EX,S4

HORIZONTAL SCALE 1:1000  
 VERTICAL SCALE 1:100

SW LONGITUDINAL SECTION  
 S2.1 TD S1

HORIZONTAL SCALE 1:1000  
 VERTICAL SCALE 1:100

SW LONGITUDINAL SECTION  
 S2.1 TD S1

HORIZONTAL SCALE 1:1000  
 VERTICAL SCALE 1:100

Rev	Date	Description	By	Check'd
A	30.06.20	SECTIONS REVISED	AM	COB
B	12.10.20	MIN 9A ABOVE, LEVELS REVISED.	AM	COB
C	17.09.21	NEW SUBMISSION	AM	COB

Client  
**MCABE DUNEY BARNES**

Project Title  
**HOUSING/DEVELOPMENT AT STOCKING LANE, BALLYBODEN DUBLIN 16**

Drawing Title  
**SURFACE WATER DRAINAGE LONGITUDINAL SECTIONS**

Architect  
**MATT BARNES**

Scale  
**AS SHOWN ON PLAN**

Client File: P:\PROJECTS\195049

The Strand Yard  
 1, 2, 3, 4, 5, 6, 7, 8, 9, 10, 11, 12, 13, 14, 15, 16, 17, 18, 19, 20, 21, 22, 23, 24, 25, 26, 27, 28, 29, 30, 31, 32, 33, 34, 35, 36, 37, 38, 39, 40, 41, 42, 43, 44, 45, 46, 47, 48, 49, 50, 51, 52, 53, 54, 55, 56, 57, 58, 59, 60, 61, 62, 63, 64, 65, 66, 67, 68, 69, 70, 71, 72, 73, 74, 75, 76, 77, 78, 79, 80, 81, 82, 83, 84, 85, 86, 87, 88, 89, 90, 91, 92, 93, 94, 95, 96, 97, 98, 99, 100