



## ENERGY & SUSTAINABILITY REPORT

for the

## PROPOSED APARTMENT DEVELOPMENT

at

**NUTGROVE AVENUE  
DUBLIN 14**

for



**La Vallee House  
Upper Dargle Road  
Bray, Co. Wicklow  
A98 W2H9  
Ireland**

**p: 00 353 (0)1 204 0005  
e: info@metec.ie  
w: www.metec.ie**



**mechanical   ■   electrical   ■   energy**

issue no.	issue date	pages	issued for	approvals		
				by	checked	approved
01	22/04/2021	32	Planning	SK	SC	MR
00	16/04/2021	31	Draft for comment	SK	SC	MR

---

**CONTENTS**

---

	<b>EXECUTIVE SUMMARY</b>
<b>SECTION 1</b>	<b>INTRODUCTION</b>
<b>SECTION 2</b>	<b>SITE AND DEVELOPMENT SUMMARY</b>
<b>SECTION 3</b>	<b>PLANNING POLICY IN SOUTH DUBLIN CITY COUNCIL (SDCC)</b>
<b>SECTION 4</b>	<b>SERVICING APPROACH</b>
<b>SECTION 5</b>	<b>SUSTAINABLE TRANSPORT LINKS</b>
<b>SECTION 6</b>	<b>ENERGY PERFORMANCE STRATEGY – RESIDENTIAL UNITS</b>
<b>SECTION 7</b>	<b>ENERGY PERFORMANCE STRATEGY – COMMUNAL AREAS</b>
<b>SECTION 8</b>	<b>WATER CONSUMPTION</b>
<b>SECTION 9</b>	<b>GREEN ROOF</b>
<b>SECTION 10</b>	<b>ELECTRIC CAR CHARGING POINTS</b>

## EXECUTIVE SUMMARY

This Energy and Sustainability report was compiled by METEC Consulting Engineers on behalf of our client, Sirio Homes, as part of the Planning Submission for the Proposed Development at the former filling station, Nutgrove Avenue, Rathfarnham, Dublin 14.

The proposed development comprises of 28 no. apartments, in a building up to 4-storeys in height located at the former filling station site, Nutgrove Avenue, Rathfarnham, Dublin 14.

Our client and the design team recognise the importance of creating a sustainable development which interplays between good urban design, accessibility to sustainable modes of transportation and the most efficient use of energy and natural resources. This report highlights how the construction and long-term management of the proposed development will be catered for and how overall energy considerations have been inherently addressed.

The design intent is to follow the requirements of the E.P.B.D. (Energy Performance of Buildings Directive), Building Regulations Technical Guidance Document (TGD) Part L and the Dublin City Development Plan 2016-2022 which are the current drivers for sustainable building design in Ireland and the city of Dublin.

The design team intend to achieve building envelope and HVAC performance that is a significant improvement on the statutory requirements contained in the Irish Building Regulations. The design team will achieve TGD Part L 2019 Nearly Zero Energy Buildings (NZEB) for the proposed development. A preliminary DEAP analysis has been undertaken on the residential units within the development to inform the design strategy, demonstrate compliance with the domestic Building Regulations Part L and to ensure that the targeted Building Energy Ratings (BERs) of A3 (or better) will be achieved.

A Thermal Dynamic Simulation Model of the communal areas has been constructed to demonstrate compliance with the non-domestic Building Regulations Part L and to ensure that the targeted BER of a B3 (or better) will be achieved using the SEAI approved NEAP methodology. This simulation model will be used to generate heating loads in an energy conscious manner and will also be used to inform key decisions in the building design such as the fabric performance metrics. NZEB will be achieved for these areas.

## RESIDENTIAL UNITS

Summary of the proposed Sustainability target:

Residential Units Energy Rating (BER) using SEAI's DEAP Methodology	A3 or Better
---	--------------

Summary of the Energy Performance Quality Assurance checks carried out:

TGD Part L 2019 section 1.3.2 - A compliance check will be carried out to ensure that the average U-value complies with the maximum permitted by the TGD standard	✓
TGD Part L 2019 section 1.3.2 - Maximum elemental U-value Check will be carried out using SEAI approved software (DEAP)	✓
The Energy Performance Coefficient (EPC) for the proposed dwellings will be calculated to ensure it is less than 0.3	✓
The Carbon Performance Coefficient (CPC) for the proposed dwellings will be calculated ensure it is less than 0.35	✓
TGD Part L 2019 section 1.2 - Minimum level of renewable energy technology to be provided check will be carried out	✓
TGD Part L 2019 section 1.3.5 - TM 59 Overheating analysis carried out on apartments	✓
TGD Part L 2019 section 1.4.5.2 - Airtightness to be under 3m <sup>3</sup> /m <sup>2</sup> /hr at 50Pa where Mechanical Ventilation is installed.	✓

## COMMUNAL AREAS

Summary of the proposed Sustainability target:

Building Energy Rating (BER) using SEAI's NEAP Methodology	B3 or Better
--	--------------

Summary of the Energy Performance Quality Assurance checks carried out:

TGD Part L 2017 section 1.3.2.2 - Overall Heat Loss Method Compliance Check will be carried out using SEAI approved software (IES VE)	✓
TGD Part L 2017 section 1.3.2.3 - A compliance check will be carried out to ensure that the average U-value complies with the maximum permitted by the TGD standard	✓
The Energy Performance Coefficient (EPC) for the proposed communal areas will be calculated to ensure it is less than 1.0	✓
The Carbon Performance Coefficient (CPC) for the proposed commercial units will be calculated to ensure it is less than 1.15	✓
TGD Part L 2017 section 1.2.1 - Renewable Energy Ratio Check will be carried out.	✓
TGD Part L 2017 section 1.3.5.3 - Solar Overheating Compliance Check will be carried out	✓

## 1.0 INTRODUCTION

This Energy and Sustainability report was compiled by METEC Consulting on behalf of our clients, Sirio Homes, as part of the Planning Submission for the Proposed Development at the former filling station, Nutgrove Avenue, Rathfarnham, Dublin 14.

The proposed development comprises of 28 no. apartments, in a building up to 4-storeys in height located at the former filling station site, Nutgrove Avenue, Rathfarnham, Dublin 14.

Both the Client and the Design Team are committed to supporting energy efficiency and energy conservation to facilitate measures which seek to reduce emissions of greenhouse gases and to promote the ethos of sustainability. Residential and commercial buildings account for 55% of total CO<sub>2</sub> emissions and represent the biggest possible opportunity for CO<sub>2</sub> abatement in Dublin (Source: Dublin City Sustainability Energy Action Plan 2010-2020).

This report highlights how the construction and long-term management of the proposed development will be catered for and how overall energy considerations have been inherently addressed. This report also addresses how the proposed development will comply with Technical Guidance Document (TGD) Part L – Conservation of Fuel and Energy 2019 (Dwellings) & 2017 (Buildings other than Dwellings) and which are the main influence on standards of energy performance and carbon dioxide emissions in Ireland. Where possible the design team intend to achieve building envelope and HVAC performance that is a significant improvement on the statutory requirements contained in the Irish Building Regulations.

It is now a requirement for all new domestic and non-domestic buildings to meet the NZEB (Near Zero Energy Building) standard. The design team will incorporate the requirements of this standard into the proposed development.

The building services design strategy for the proposed development utilises as many sustainable design options and energy efficient systems that are technically, environmentally and economically viable for the project to achieve a low energy and environmentally friendly development, while also providing suitable dwellings to meet current market demands.

## 2.0 SITE AND DEVELOPMENT SUMMARY

Sirio Homes intend to apply to South Dublin County Council for permission for residential development comprising a total of 28 no. apartments, in a building up to 4-storeys in height located at the former filling station site, Nutgrove Avenue, Rathfarnham, Dublin 14. The cumulative gross floor area is proposed to be 2,640sq.m on the 0.3157 hectare site.

The application area includes the site of the former filling station (0.2821 ha – under Applicant ownership) and a portion of land (0.0326ha) located to the north of the filling station site, where the existing traffic lights and pedestrian crossing are located along Nutgrove Avenue. To accommodate access to the Site, it is proposed to relocate the existing traffic lights and pedestrian crossing which traverses both South Dublin County Council and Dun Laoghaire-Rathdown County Council boundaries.

The development will consist of:

- i. The development proposes a development with a maximum height of c.11.7m and a total gross floor area of 2,640 sq.m consisting of 28 no. residential units comprising:
  - 8 x 1-bedroom apartments
  - 17 x 2-bedroom apartments
  - 3 x 3-bedroom apartments;
- ii. Communal amenity space (433 sq.m) and public open space (286 sq.m) located to the rear and western side of the Site;
- iii. At grade car parking is proposed to the rear of the site which will provide 16 no. residents' car parking spaces (including 2 no. electric vehicles spaces and 1 no. accessible spaces) and 2 no. motorcycle parking spaces;
- iv. Two (2) resident waste bin storage areas are proposed along the north-western and north-eastern corner of the Site, fronting Nutgrove Avenue (Total 25 sq.m);
- v. A new vehicular entrance from Nutgrove Avenue;
- vi. A total of 62 no. surface level bicycle parking spaces comprising 48 no. spaces located at the rear of the Site and 14 no. spaces within the residents' communal area, located along the north-western portion of the Site;
- vii. Relocation of the existing traffic lights and pedestrian crossing located on Nutgrove Avenue 11m to the west of its existing position to accommodate access to the Site; and
- viii. All ancillary site development works including installation of drainage and water supply infrastructure, lighting and provision of an ESB substation and switch room.



Figure 2.0 Aerial View of site



Figure 2.1 Site Plan



The proposed site plan is identified in figure 2.1 above.

### 3.0 PLANNING POLICY IN SOUTH DUBLIN COUNTY COUNCIL (SDCC)

The following policy of South Dublin County Council are relevant to the Proposed Development:

#### **Policy SDCC1: RESPONDING TO EUROPEAN AND NATIONAL ENERGY POLICY AND LEGISLATION**

It is the policy of the Council to respond to the European and National Energy Programme through the County Development Plan – with policies and objectives that promote energy conservation, increased efficiency and the growth of locally based renewable energy alternatives, in an environmentally acceptable and sustainable manner.

#### **Project Team Response to SDCC Energy Policy 1:**

Our client and the design team recognise South Dublin County Council planning policy and the importance of creating a sustainable development that contributes towards Irelands commitment to a range of renewable energy and efficiency targets, many of which are being implemented as Climate Change policy measures to reduce carbon emissions.

At the forefront of the design development will be the recognition that new buildings need to be designed, constructed and operated in an energy efficient manner that will have minimal effect on the local environment while achieving an internal environment that is comfortable, functional, and enjoyable to occupy and provides a cost optimal design solution. If new residential design is to avoid adding to the problem of global warming, there is proportionately less pressure on the far more complex issue of making the existing stock more energy efficient, while still meeting the Government energy and carbon reduction targets. As per the EU 2009 Renewable Energy Directive Ireland is committed to meeting its share of energy and carbon related targets for 2020.

For this proposed development, the design intent will be to pay close attention to the requirements of the EPBD (Energy Performance Building Directive), the South Dublin County Council Development Plan 2016 – 2022 and Building Regulations Technical Guidance Document Part L 2019 (Dwellings) and 2017 (Buildings other than Dwellings) editions which are the current drivers for sustainable building design in Ireland.

The intent is to ensure that the building services (mechanical and electrical) design strategy is to utilise as many sustainable design options and energy efficient features that

are technically, environmentally and economically feasible for the project in an aim to achieve a new mixed-use development that is low energy and environmentally friendly. Making the right decisions in relation to the design / construction can contribute greatly to the sustainability of a building, which will lead to cost savings in the future and raise comfort levels for the occupants of the building.

The design approach that shall be adopted for this development will be the LEAN, CLEAN, GREEN Approach.

**Lean:** The design intent is to reduce the demand for energy by designing efficiency into the very fabric of the building. This focus will extend to air tightness, thermal bridges and solar control, as well as taking into account the thermal mass of the areas being considered. A full DEAP (Domestic Energy Assessment Procedure) shall be carried out for all residential units to ensure compliance with TGD Part L 2019. All residential units on the site shall achieve the required Energy Performance Coefficient (EPC) and Carbon Performance Coefficient (CPC) in accordance with the DEAP methodology. Separately a full NEAP (Non-Domestic Energy Assessment Procedure) and NZEB Analysis shall be carried out for the commercial units and apartment common areas to ensure compliance with TGD Part L 2017.

**Clean:** In specifying mechanical and electrical services the design intent is to use systems that are best in class technology and most efficient in their range. Consideration will be given to both the embodied energy and the energy consumed over its lifespan within the building. This is relevant to the heating system, hot water generation, ventilation systems and lighting. The design team will also focus on the control and metering these energy end uses which would greatly assist future energy measurement and verification activities.

**Green:** leveraging renewable technologies to a higher degree due to the greatly reduced energy requirements of the building.

By adopting this approach ensures that where renewable technologies are considered, they are sized efficiently, not based on excessive over-sized plant loads. This approach helps to develop a more cost efficient renewable solution.

South Dublin County Council is committed to encouraging more sustainable development, the efficient use of energy and the use of renewables in new buildings. In accordance with SDCC Planning Policy, a feasibility assessment shall be carried out to determine the practical, economic and environmental benefits of such technologies for this development.

## **Policy SDCC2: SOUTH DUBLIN SPATIAL ENERGY DEMAND ANALYSIS**

It is the policy of the Council to implement the recommendations of the South Dublin Spatial Energy Demand Analysis (SEDA) in conjunction with all relevant stakeholders, promoting energy efficiency and renewable energy measures across the County.

### **Project Team Response to SDCC Policy 2;**

Our client and the design team recognise South Dublin County Council planning policy and the importance of creating a sustainable development which interplays between good urban design, accessibility to sustainable modes of transportation, maximising the links between existing social and community infrastructure and the most efficient use of energy and natural resources.

In achieving the aim of this policy, it is intended that the proposed development not only achieve compliance with National and European regulations but will also represent class leading energy efficient design with a clear emphasis on reducing overall energy consumption in a holistic and measurable way. The SEDA strategy makes reference to the BER (Building Energy Rating) scheme being a measure of energy efficiency to benchmark buildings against. The design intent to achieve A2/A3 BER ratings in all dwellings. The dwellings will also be compliant with NZEB, which represents a minimum of a 70% reduction in overall energy consumption in a new dwelling versus an equivalent dwelling built to TGD Part L (Dwellings) 2005.

Objective 7 makes particular reference to the provision of Solar PV to all new dwellings. This technology is being considered for this development but would form part of an overall renewable energy strategy that would also include other technologies with a renewable element such as Air to Water and Exhaust Air heat pumps which are very discreet technologies that can provide heating in a sustainable manner with no direct emissions to the atmosphere. These technologies also consume significantly less primary energy than traditional approaches to heating such as gas or oil.

This planning policy also deals with Energy Efficient Design however this will be dealt with specifically under section 8.0 of this report – Energy Performance Strategy.

### **Policy SDCC4 ENERGY PERFORMANCE IN NEW BUILDINGS**

It is the policy of the Council to ensure that new development is designed to take account of the impacts of climate change, and that energy efficiency and renewable energy measures are considered in accordance with national building regulations, policy and guidelines.

### **Project Team Response to SDCC Policy 4;**

#### **DWELLINGS**

On average, about 40% of the total energy consumption in industrialised countries is used for buildings. Due to the long service life of buildings, a consistent approach is especially important in this respect in improving energy standards at the earliest design stages. Significantly improving energy efficiency standards at the outset could prove cost optimal as any additional costs can be recouped over the life cycle of the building. Improvement in the energy efficiency of buildings should be encouraged as it will have a considerable impact on the overall assessment of the area in terms of energy.

With this in mind all dwellings shall comply in full with TGD Part L (Dwellings) 2019. The aim of Part L of the second schedule is to limit the use of fossil fuel energy and related carbon dioxide (CO<sub>2</sub>) emissions arising from the operation of buildings, while ensuring that occupants can achieve adequate levels of lighting and thermal comfort.

In adopting the requirements of Part L (2019) the design team will fully address the following key issues in order to ensure compliance;

- Whole Building Performance (Primary Energy Consumption and Related CO<sub>2</sub> emissions using DEAP software)
- Use of Renewable Energy Sources
- Fabric Insulation
- Air Tightness
- Boiler Efficiency
- Building Services Controls
- Insulation of Pipes, Ducts and Vessels
- Mechanical Ventilation Systems
- User Information

The Dwelling Energy Assessment Procedure (DEAP) is the Irish official method for calculating the energy performance of dwellings. The factors that contribute to annual energy usage and associated CO<sub>2</sub> emissions for the provision of space heating, water heating, ventilation and lighting in DEAP include the following:

- Size, geometry and exposure
- Construction materials
- Thermal insulation properties of the building fabric elements
- Dwelling ventilation characteristics and ventilation equipment
- Heating system(s) efficiency, responsiveness and control characteristics
- Solar gains through glazed openings (free heat)
- Thermal storage (mass) capacity of the dwelling
- Fuels used to provide space and water heating, ventilation and lighting
- Lighting specification and control strategies
- Renewable and alternative energy generation technologies

DEAP is used to demonstrate compliance with the EPBD in Ireland including elements of the Irish Building Regulations Part L 2019 for new dwellings. DEAP compares the dwelling's Energy Performance Coefficient (EPC) and Carbon Performance Coefficient (CPC) to the Maximum Permitted Energy Performance Coefficient (MPEPC) and Maximum Permitted Carbon Performance Coefficient (MPCPC) as defined in TGD Part L 2019. DEAP also determines if the Building Regulations TGD Part L renewables requirement is satisfied.

The primary energy consumption and carbon dioxide (CO<sub>2</sub>) emissions of the dwellings in the Nutgrove Avenue development, including the services design, will be calculated using the DEAP methodology. In order to demonstrate that an acceptable primary energy consumption rate has been achieved, the dwellings will be designed to meet the following parameters;

Metric	Requirements under TGD Part L 2019	% Energy Reduction vs. TGD Part L 2005 dwelling
MPEPC	< 0.30	70%
MPCPC	< 0.35	65%
RER	> 0.20	n/a

All dwellings in the Nutgrove Avenue development will be designed in accordance with TGD Part L 2019 and will be compliant with NZEB

#### **BUILDINGS OTHER THAN DWELLINGS**

NEAP is the tool used for demonstrating compliance with TGD Part L 2017 for buildings other than dwellings. NEAP is also approved by SEAI for the issuing of BER Certificates

for buildings other than dwellings. As with DEAP, NEAP calculates the EPC, CPC & RER on the basis of the building characteristics including, but not limited to:

- Size, geometry and exposure
- Construction materials
- Thermal insulation properties of the building fabric elements
- Dwelling ventilation characteristics and ventilation equipment
- Heating system(s) efficiency, responsiveness and control characteristics
- Solar gains through glazed openings (free heat)
- Thermal storage (mass) capacity of the dwelling
- Fuels used to provide space and water heating, ventilation and lighting
- Lighting specification and control strategies
- Renewable and alternative energy generation technologies

NEAP uses SBEM as its calculation engine and IES Virtual Environment as the User Interface for inputs. The software operates on a "Zoning" principle allowing multiple uses of spaces within a building to be considered within a single calculation. This approach also allows for the input of multiple systems for occupant comfort to be modelled separately and accurately. NEAP also determines if the Building Regulations TGD Part L 2017 renewables requirement is satisfied.

The proposed development will meet or exceed, the requirements of the current building regulations, in particular Part L 2017 (Buildings other than dwellings), which stipulates requirements on minimum renewable contribution, minimum fabric and air permeability requirements, maximum energy use and carbon dioxide emissions.

It must be noted that TGD Part L 2017 is the current guidance document applicable to all new developments other than dwellings. The design team are working to TGD Part L 2017. It must be noted that TGD Part L 2017 sets out the requirements for compliance Near Zero Energy Buildings (NZEB) for buildings other than dwellings. All non-dwelling areas of the proposed development will comply with NZEB.

The primary energy consumption and carbon dioxide (CO<sub>2</sub>) emissions of Nutgrove Avenue, including the services design, will be calculated using the NEAP methodology. In order to demonstrate that an acceptable primary energy consumption rate has been achieved, the calculated Energy Performance Coefficient (EPC) will be no greater than the Maximum Permitted Energy Performance Coefficient (MPEPC). The MPEPC under TGD Part 2017 is 1.00

To demonstrate that an acceptable CO<sub>2</sub> emission rate has been achieved, the calculated Carbon Performance Coefficient (CPC) of the building being assessed will be no greater than the Maximum Permitted Carbon Performance Coefficient (MPCPC). The MPCPC under TGD Part L 2017 is 1.15

When calculating the EPC & CPC of a building, NEAP compares the "Actual Building" to the NZEB "Reference Building" using the inputs specified in Table C1 of TGD Part L 2017. The design of the reference building is based on a typical NZEB compliant building and uses the Geometry of the actual building to carry out the EPC & CPC checks. The NZEB reference building is intended to represent approximately a 60% improvement in performance compared to a TGD Part L 2005 building.

Under TGD Part L 2017, a significant proportion of the overall building energy consumption must come from renewable sources. This metric is referred to as Renewable Energy Ratio (RER). The Renewable Energy Ratio (RER) requirements are set out below:

EPC	CPC	RER
0.9 ≤ 1.0	1.04 ≤ 1.15	0.2 or 20%
< 0.9	< 1.04	0.1 or 10%

All non-dwelling areas of Nutgrove Avenue will be designed in accordance with TGD Part L 2017 and will be compliant with NZEB.

### **Policy SDCC7: SOLAR ENERGY**

It is the policy of the Council to promote the development of solar energy infrastructure in the County, in particular for on-site energy use, including solar PV, solar thermal and seasonal storage technologies. Such projects will be considered subject to environmental safeguards and the protection of natural or built heritage features, biodiversity and views and prospects.

### **Project Team Response to SDCC Policy 7;**

The Design Team are actively looking at solar technology for providing clean, renewable energy for this development. The costs of Solar PV has reduced in recent years and become an economically viable technology for use in all types of buildings.

### **Photovoltaic Cells (PV)**

#### **Technology Description**

Photovoltaic (PV) modules convert sunlight/daylight to DC electricity. The solar cells consist of a thin piece of semiconductor material, in most cases of silicon. Through a process called doping, a very small amount of impurities are added to the semiconductor, which creates two different layers called n-type and p-type layers. Certain wavelengths of light are able to ionise the silicon atoms, which separates some of the positive charges (holes) from the negative charges (electrons). The holes move into the positive or p-layer and the electrons into the negative or n-layer. These opposite charges are attracted to each other, but most of them can only re-combine by the electrons passing through an external circuit, due to an internal potential energy barrier. This flow of electrons produces a DC current.

#### **Applicability to this Development**

As the cost of PV reduces overtime it is becoming a more attractive renewable technology. PV modules can be integrated into the building fabric, such as roofing material, and this cost offset can improve viability. At detailed design stage a full lifecycle cost assessment will be carried out for a PV installation which shall include maintenance and degradation of the panels over time. PV panels are high in embodied energy and this would need to be considered by the design team. Allocation of suitable unshaded roof will be critical if



PV is considered for this project. The renewable contribution shall be modelled using the DEAP Compliance Software.

## Solar Thermal Water Heating

### Technology Description

Solar water heating systems use the energy from the sun and/or daylight to heat water, most commonly for washing and cleaning requirements in a building. Solar heating systems use a heat collector that is usually mounted on a roof in which a fluid is heated by the sun. The system is installed with a mixture of antifreeze and water circulating through the collectors and a heat exchanger in the domestic hot water tank. The indirectly-heated water in the tank is then supplied to outlets such as taps and showers. A controller compares the temperature of the water in the collectors with the temperature of the water in the cylinder and activates a circulating pump whenever the water in the collectors is hotter. A conventional boiler is used to boost the stored hot water when required.

Solar energy collectors generally come with a 10-year warranty and require little maintenance (largely limited to ensuring that the panels are kept clean). Pollution has little effect on the units as they are maintenance free and rain will help to keep the surface clean.

Solar collectors can be categorised into the following two types;

- Glazed flat plate collectors
- Evacuated tube collectors



Evacuated tube collector



Glazed flat plate collectors

### **Applicability to this Development**

In the Dublin area there is an annual average solar energy availability of 1MWh/m<sup>2</sup> at the optimum (south facing) angle of 35-45° from the horizontal plane. The amount of this energy that can be utilised is dependent upon the availability of un-shaded roof / façade space and the efficiency of the solar panels themselves.

During the detailed design stage, the likely DHW demand and demand profile will be reviewed in detail and estimates on the proportion of the domestic hot water that can be met by solar water heating will be made and presented to the design team for consideration. It is unlikely that solar thermal water heating alone will comply with the TGD Part L renewable requirements.

### **Seasonal Storage Technologies**

#### **Technology Description**

Various technologies are being developed for the storage of thermal and electrical energy to allow the charging up of the storage in times of excess (summer) for use in times of scarcity (winter). Many approaches are being developed including using aquifers, boreholes, mines, liquids along with various other approaches.

#### **Applicability to this Development**

It is unlikely that any seasonal storage would be viable for use in this development, however, given the rapid pace of technology development, it will be kept under review as the project progresses and should a suitable technology become viable, it will be considered.

### **DESIGN APPROACH**

The intent for the building services (mechanical and electrical) design strategy is to utilise as many sustainable design options and energy efficient features that are technically, environmentally and economically feasible for the project in an aim to achieve a new residential development that is low energy and environmentally friendly. Making the right decisions in relation to the design / construction can contribute greatly to the sustainability of a building, which will lead to cost savings in the future and raise comfort levels for the occupants of the building.

The design approach that shall be adopted for this development will be the LEAN, CLEAN, GREEN Approach.

**Lean:** The design intent is to reduce the demand for energy by designing efficiency into the very fabric of the building. This focus will extend to air tightness, thermal bridges and solar control, as well as taking into account the thermal mass of the areas being considered. A full DEAP (Domestic Energy Assessment Procedure) shall be carried out for all residential units to ensure compliance with TGD Part L 2019 and 2017. All residential units on the site shall achieve the required Energy Performance Coefficient (EPC) and Carbon Performance Coefficient (CPC) in accordance with the DEAP methodology. Separately a full NEAP (Non-Domestic Energy Assessment Procedure) and NZEB Analysis shall be carried out for the commercial units to ensure compliance with TGD Part L 2017.

**Clean:** In specifying mechanical and electrical services the design intent is to use systems that are best in class technology and most efficient in their range. Consideration will be given to both the embodied energy and the energy consumed over its lifespan within the building. This is relevant to the heating system, hot water generation, ventilation systems and lighting. The design team will also focus on the control and metering these energy end uses which would greatly assist future energy measurement and verification activities.

**Green:** leveraging renewable technologies to a higher degree due to the greatly reduced energy requirements of the building.

By adopting this approach ensures that where renewable technologies are considered, they are sized efficiently, not based on excessive over-sized plant loads. This approach helps to develop a more cost-efficient renewable solution.

South Dublin Council is committed to encouraging more sustainable development, the efficient use of energy and the use of renewables in new buildings. In accordance with South Dublin Council Planning Policy, a feasibility assessment shall be carried out to determine the practical, economic and environmental benefits of such technologies for this development.

#### **4.0 SERVICING APPROACH**

The intent for the building services (mechanical and electrical) design strategy is to utilise as many sustainable design options and energy efficient features that are technically, environmentally and economically feasible for the project in an aim to achieve a development that is low energy and environmentally friendly. Making the right decisions in relation to design / construction can contribute greatly to the sustainability of a

building, which will lead to cost savings in the future and raise comfort levels for the occupants of the buildings.

Typical considerations when defining our approach include but are not limited to the following:

- Our Clients preferences i.e. Centralised vs Decentralised system
- Space Heating & Hot Water needs of the buildings
- Choice of fuel, in particular with reference to net carbon emissions
- Overall Running Costs
- Capital Costs & Ongoing Maintenance requirements
- Regulatory Requirements i.e. NZEB, TGD's etc.

Servicing approaches that have been considered for this development include:

- District Heating with CHP and/or Air Source Heat Pumps (ASHP)
- Individual Heat Pumps
- Exhaust Air Heat Pumps
- Gas Boilers with Solar Photovoltaic

#### **District Heating with CHP and/or Air Source Heat Pumps (ASHP)**

This approach uses centralised heating plant which typically includes Combine Heat & Power and/or ASHP's with Gas fired boilers for meeting the peak loads i.e. very cold weather or morning hot water peak.

Heat is produced efficiently by the centralised plant and delivered via highly insulated main pipes to each dwelling unit for heating and hot water, both of which are produced in a Heat Interface Unit (HIU) within each dwelling. It is important to note that the electricity produced by the CHP is used directly by the ASHP which has a Seasonal Coefficient of Performance of c.3.0. This effectively means that for every 1 kWh of natural gas input into the heating plant results in c. 1.4 kWh of high-grade heat is being delivered to the dwellings. Such an arrangement can meet the renewable requirements of TGD Part L 2019.

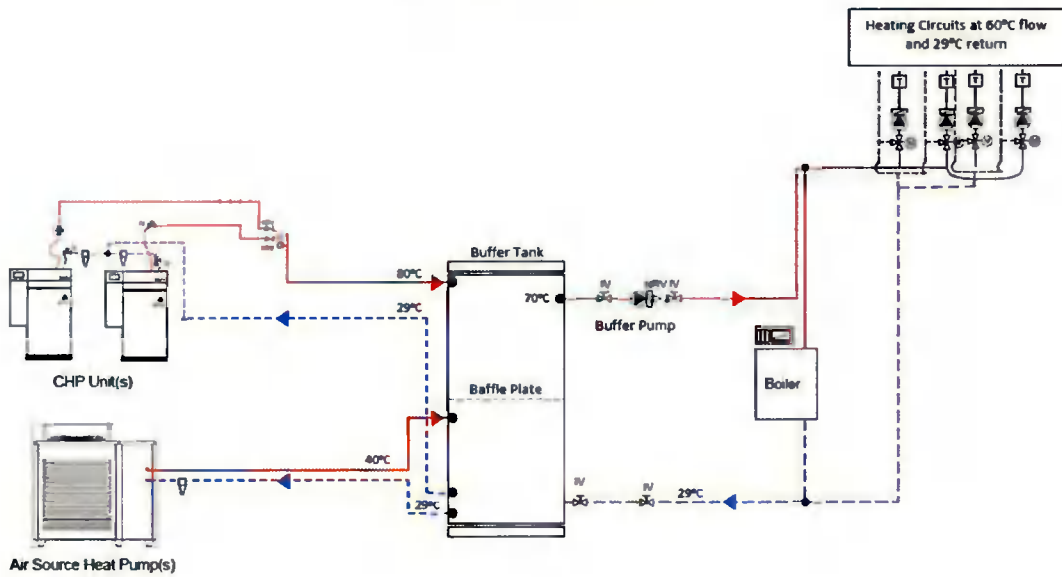

Fig. 4.1 – Typical Centralised Heating Plant incorporating CHP and Heat Pumps with Gas Boilers for meeting Peak Loads

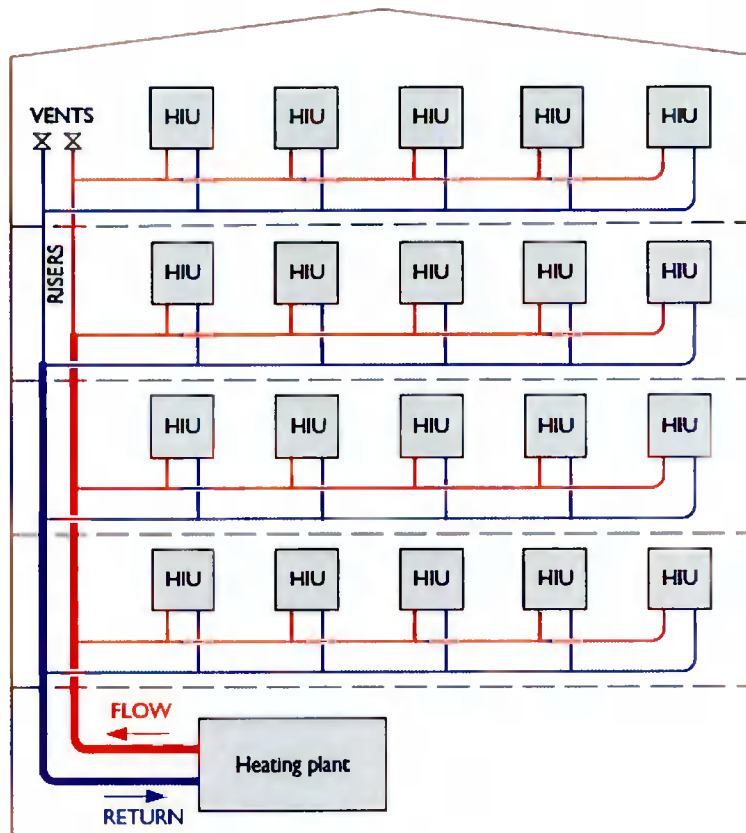

Fig. 4.2 - Apartment block with district heating using Heat Interface Units.

### Individual Air Source Heat Pumps (ASHP)

Air Source Heat Pumps utilise low grade environmental heat from the outside air and use refrigerant cycle to convert this heat into high grade heat that can be used with radiators or underfloor heating and to produce hot water in a very efficient manner. The heat pump then transfers this energy to a water circuit for space heating and hot water production.

As most of the energy is extracted from the outside air, the efficiency of this system, measured using a metric called SCOP (Seasonal Coefficient of Performance) is very favourable in terms of energy and running costs. For example, typically, one kWh of grid supplied electricity will generate between 3 & 4 kWh of heating depending on the system.

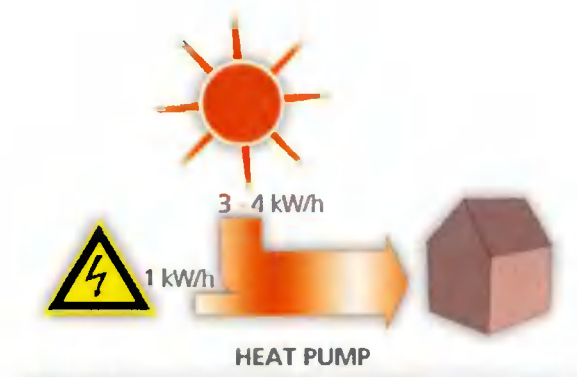

Fig. 4.3 – Heat Pump Energy Balance Illustration



Fig. 4.4 – Typical Air Source Heat Pump Installation

### Exhaust Air Heat Pumps (EAHP)

An all-in-one unit – Heat recovery ventilation, Heating and Hot water. Suitable for apartments that will be at a high level of air-tightness and low heat loss. Therefore, the building envelope will need to achieve low U-values. This unit is not suitable for existing building where it has not been possible to upgrade the building envelope thermal performance to meet the current standards. For this system to work effectively, the building needs to be air tight with low heat loss.

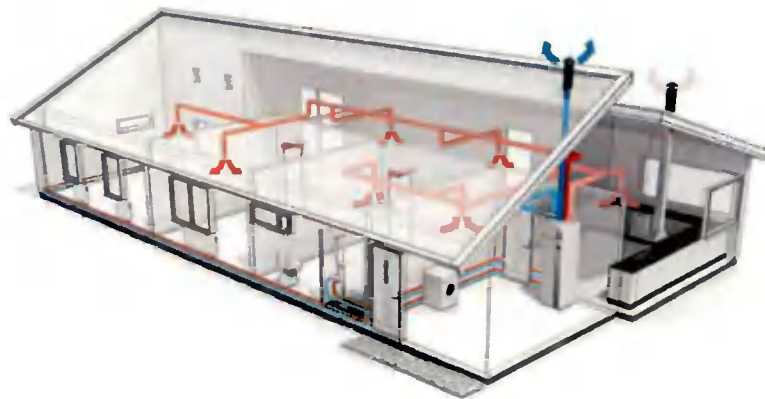

Fig. 4.5 – Typical Exhaust Air Heat Pump Installation

An Exhaust Air Heat Pump (EAHP) extracts heat from the exhaust air and transfers the heat to domestic hot water and/or hydronic heating system (underfloor heating, radiators). This type of heat pump requires a certain air exchange rate to maintain its output power. Since the inside air is approximately 20-22 degrees Celsius all year round, the maximum output power of the heat pump is not varying with the seasons and outdoor temperature. It has similar operating characteristics to an Air Source Heat Pump, for every 1 kWh of electricity inputted, 3-4 kWh of usable heat is produced.



Fig. 4.6 – Typical Exhaust Air Heat Pumps

### **Gas Boilers with Photovoltaic Cells (PV)**

In this approach, traditional gas boilers are used to provide space heating and hot water in a conventional manner with Solar Photovoltaic panels used to meet the renewable requirements of TGD Part L.

Photovoltaic (PV) modules convert sunlight/daylight to DC electricity. The solar cells consist of a thin piece of semiconductor material, in most cases of silicon. Through a process called doping, a very small amount of impurities is added to the semiconductor material, which creates two different layers called n-type and p-type layers. Certain wavelengths of light are able to ionise the silicon atoms, which separates some of the positive charges (holes) from the negative charges (electrons). The holes move into the positive or p-layer and the electrons into the negative or n-layer. These opposite charges are attracted to each other, but most of them can only re-combine by the electrons passing through an external circuit, due to an internal potential energy barrier. This flow of electrons produces a DC current.

As the cost of PV reduces overtime it is slowly becoming a more attractive renewable technology. PV modules can be integrated into the building fabric, such as roofing material, and this cost offset can improve viability. At detailed design stage a full lifecycle cost assessment will be carried out for a PV installation which shall include maintenance and degradation of the panels over time. PV panels are high in embodied energy and this would need to be considered by the design team.

### **Conclusion**

While Centralised District Heating and Gas Boilers with Solar PV are both tried and tested technologies, they have a significant disadvantage in that they both use fossil fuel natural gas and have relatively high CO<sub>2</sub> emissions per kWh of heat produced. This is not ideal and is not future-proofed.

Both ASHP and EAHP options have a significant advantage in that they use electricity and convert each kWh of electricity into 3-4 kWh of usable heat. As the national grid currently uses high volumes of renewable energy and is likely to become carbon neutral in the



future, by default, any dwelling heated using an electrically powered heat pump will also become carbon neutral.

Therefore, the proposed development will use Exhaust Air Heat Pumps in all dwellings. This approach will ensure that the dwellings are not only provided with a low emission heating system but are also future-proofed for future grid improvements.

## 5.0 SUSTAINABLE TRANSPORT LINKS

Our Client and the Design Team recognise the importance of creating a sustainable development which interplays between good urban design, accessibility to sustainable modes of transportation, maximising the links between existing social and community infrastructure and the most efficient use of energy and natural resources.

The site is served by Dublin bus links (17, 17D, 61, 75 and 75A)



Figure 5.1: Bus Stop Locations in relation to site

Additionally, dedicated and secure cycle parking will be provided throughout the development in accordance with the South Dublin County Council Development Plan. A total of 62 no. surface level bicycle parking spaces comprising 48 no. spaces located at the rear of the site and 14 no. spaces within the residents' communal area, located along the north-western portion of the site are proposed, thus encouraging sustainable modes of transport.

## 6.0 ENERGY PERFORMANCE STRATEGY – RESIDENTIAL UNITS

The design intent is to incorporate the following passive design measures for the proposed residential units where it is both technically and economically practical. These design parameters are the current targets and are subject to amendment during design development. As a minimum, all U-Values shall comply in full with TGD Part L 2019 (current edition for Dwellings).

Element	Performance Target
Roof U-Value	0.15 W/m <sup>2</sup> °K (target value).
Wall U-Value	0.15 W/m <sup>2</sup> °K (target value).
Floor U-Value	0.15 W/m <sup>2</sup> °K (target value).
Window U-Value	1.20 W/m <sup>2</sup> °K (target value including window frame).
Building Air Permeability	≤3.0 m <sup>3</sup> h <sup>-1</sup> m <sup>-2</sup> @50Pa (target value) All dwellings to be tested and certified.
Thermal Bridging	Acceptable Construction Details to be specified and followed on site.
Lighting	LED Lighting Throughout.
Ventilation	Mechanical Ventilation via the EAHP.

Table 6.1

## 7.0 ENERGY PERFORMANCE STRATEGY – COMMUNAL AREAS

The design intent is to incorporate the following passive design measures for the proposed communal areas where it is both technically and economically practical. Many of these target values also comply with or exceed the requirements of TGD Part L 2017 specification for Buildings other than Dwellings.

These design parameters are the current targets and are subject to amendment during design development. As a minimum, all U-Values shall comply in full with TGD Part L 2017 (current edition for Buildings other than Dwellings).

Element	Performance Target
Roof U-Value	0.15 W/m <sup>2</sup> °K (target value).
Wall U-Value	0.15 W/m <sup>2</sup> °K (target value).
Floor U-Value	0.15 W/m <sup>2</sup> °K (target value).
Window U-Value	1.20 W/m <sup>2</sup> °K (target value including window frame).
Window G-Value to EN410	0.40-0.55 (target range). This will help to reduce unwanted solar gain and in turn reduce unwanted overheating in summer.
Light Transmittance	0.65 - 0.71 (target range) – the highest value possible shall be specified where feasible.
Building Air Permeability	≤3.0 m <sup>3</sup> h <sup>-1</sup> m <sup>-2</sup> @50Pa (target value) All units and communal areas to be tested and certified.
Lighting	LED Throughout with PIR sensors in communal hallways to reduce electricity consumption.

Table 7.1

By implementing these passive design measures energy consumption associated with heating and lighting will be reduced considerably at source.



## 8.0 WATER CONSUMPTION

Our Client and the Design Team is committed to identify opportunities to reduce potable water consumption for this project. An analysis will be performed that explores how to reduce potable water loads in the building and accomplish related sustainability goals.



Figure 8.1 Sanitary ware fixtures and fittings

Figure 8.1 shows an example of Sanitary ware fixtures and fittings that will be reviewed in detail in order to help reduce potable water consumption for this project.

## 9.0 GREEN ROOF

A green roof will be provided for sections of roof areas as outlined in the Architectural and Landscape Plans. Consideration will be given to the structural viability, uniformity and local character. A green roof is a purposely fitted or cultivated roof with vegetation. There are many different types of green roofs and they provide many different benefits which include;



Figure 9.1 Green Roof Solutions

### **Reducing energy use**

Green roofs have been shown to impact positively on a building's energy consumption by improving its thermal performance, although the amount of difference this makes varies depending on daily and seasonal weather.

### **Climate change mitigation**

Residential and commercial buildings account for 55% of total CO<sub>2</sub> emissions and represent the biggest possible opportunity for CO<sub>2</sub> abatement in Dublin (Source: Dublin City Sustainability Energy Action Plan 2010-2020). A high proportion of these emissions are from heating and cooling the internal environment. Reducing the energy consumption of Dublin's buildings will reduce their impact on climate change. Green roofs can significantly reduce the cooling load of a building and may have a positive effect on the heating load.

### **Lessening the urban heat island effect**

The urban heat island effect is the temperature disparity between urbanised areas and surrounding rural areas. Urban landscapes have a much higher proportion of tough, impermeable, darker surfaces (typified by conventional roof surfaces) which favour the retention of heat. Urban surfaces can convert up to 95% of the net incoming solar radiation into heat and in large cities this can result in a 4 °C variation between the city and surrounding areas, usually experienced at night. The urban heat island effect will increase as summer temperatures increase and will therefore become even more of a problem in Dublin in the future. Green roofs have very different evaporative, thermal and albedo (reflectivity) qualities from conventional roof types. Specifying a green roof over a bitumen roof effectively modifies the contribution of several factors key to the impact of the urban heat island effect; evaporating surfaces are increased, storage of heat within the building fabric is reduced, and the local albedo is positively altered.

### **Improving local air and water quality**

The urban heat island effect exacerbates ground-level ozone production, which is formed by a reaction between volatile organic compounds and nitrous oxides catalysed by heat and sunlight. It is classified as a pollutant and is the foremost component of smog. Through mitigating the urban heat island effect, as well as producing oxygen, green roofs can thus improve local air quality. Having a green roof can also help to remove airborne particles, heavy metals and volatile organic compounds from the local atmosphere. As these contaminants are retained by the green roof itself, their infiltration of the water system through surface runoff is lessened, in turn improving local water quality.



## 10.0 ELECTRIC CAR CHARGING POINTS

It is the design intent to specify a number of electric car charging points within the carpark, with electrical infrastructure provided to all parking spaces for the future upgrade to electric charging. Two (2) EV parking spaces are proposed and the car park is proposed to be fully ducted to facilitate amendments to the standard car parking spaces, should additional EV parking spaces be required in the future.

Electric cars offer a real opportunity to reduce the carbon output of the transport sector, as they emit zero exhaust pipe emissions. Providing electric car charging points will encourage the buildings users towards this sustainable mode of transport.



Figure 10.1 Electric Car Charging Points

