

GENERAL NOTES

- DO NOT SCALE THIS DRAWING. WORK ONLY TO FIGURED DIMENSIONS.
- FOR ALL RELEVANT NOTES, REFER TO STRUCTURAL AND CIVIL ENGINEERING PERFORMANCE SPECIFICATION.
- ANY DISCREPANCIES ARE TO BE REPORTED TO PINNACLE CONSULTING ENGINEERS IMMEDIATELY.
- THIS DRAWING IS TO BE READ IN CONJUNCTION WITH ALL OTHER RELEVANT ENGINEERING ARCHITECTS AND SUB-CONTRACTORS DRAWINGS AND DETAILS.

WASTEWATER SERVICE CONNECTION RESPONSIBILITY

| | |
|----------------------------|-------------|
| MAINTENANCE RESPONSIBILITY | SEWER WATER |
| PROPERTY OWNER | SEWER WATER |
| PROPERTY OWNER | SEWER WATER |
| PROPERTY OWNER | SEWER WATER |
| PROPERTY OWNER | SEWER WATER |
| PROPERTY OWNER | SEWER WATER |
| PROPERTY OWNER | SEWER WATER |
| PROPERTY OWNER | SEWER WATER |
| PROPERTY OWNER | SEWER WATER |
| PROPERTY OWNER | SEWER WATER |

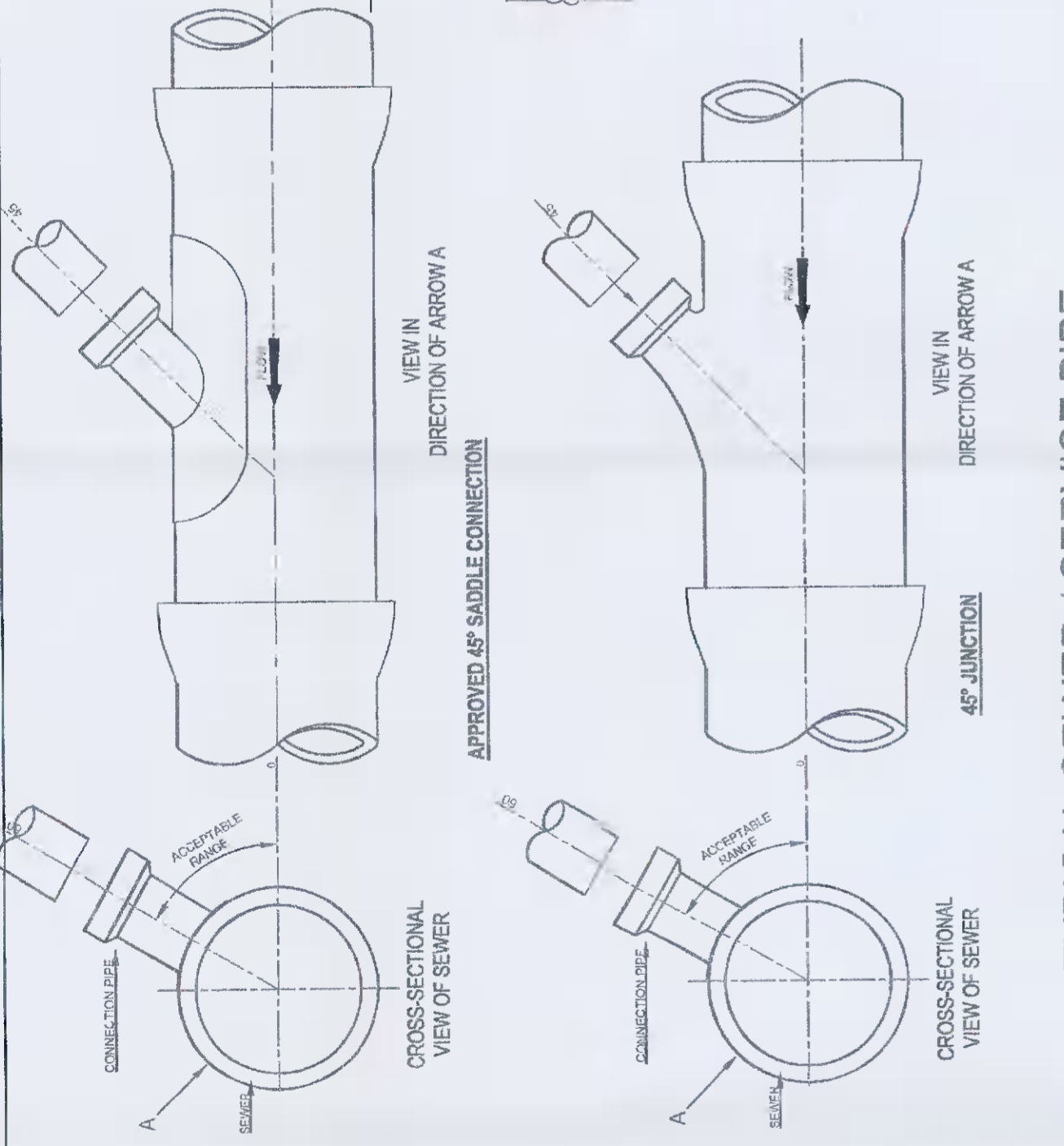
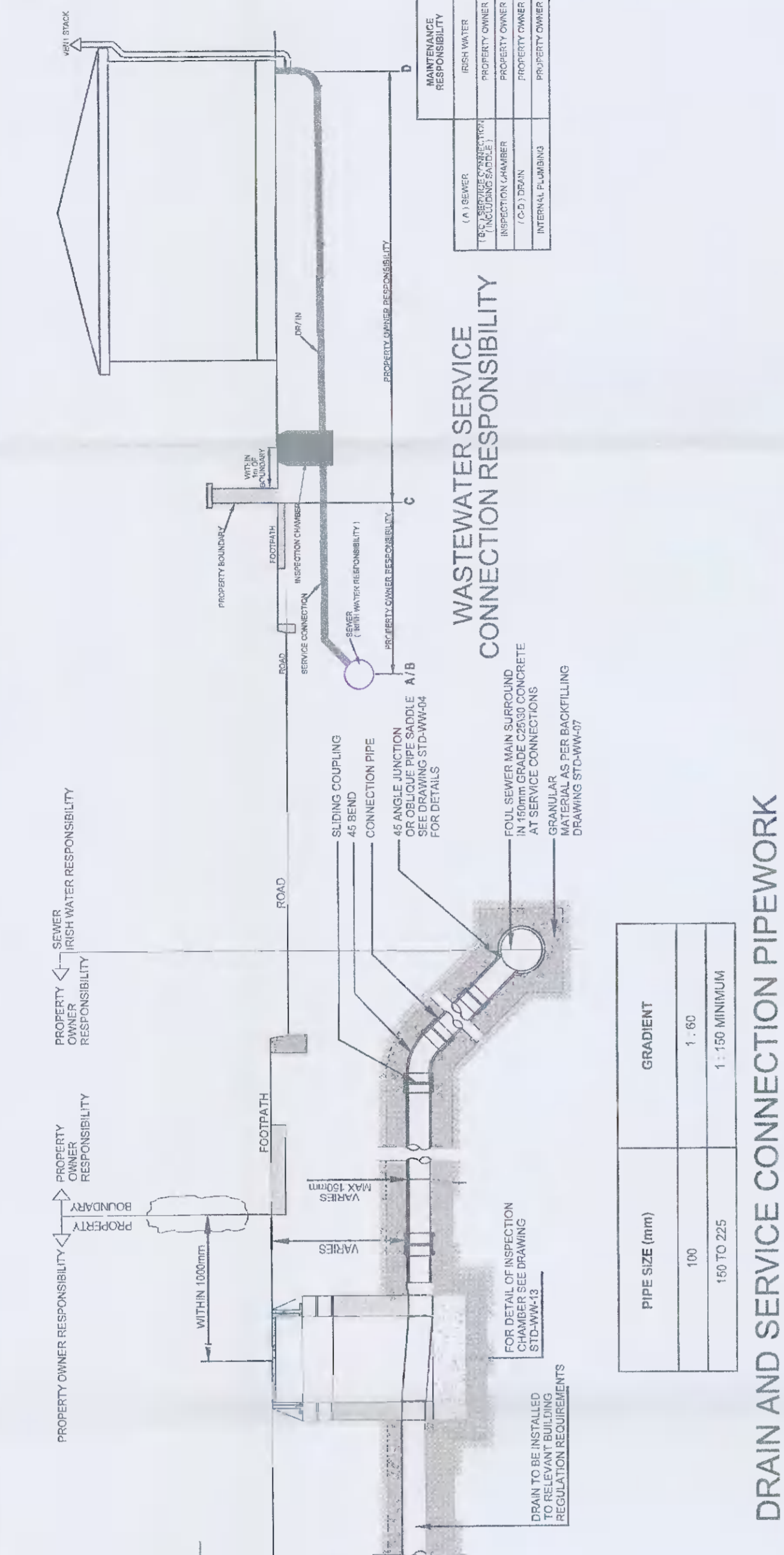

TYPICAL SEWER / SERVICE PIPE CONNECTION DRAWING No. STD-WW-04

TYPICAL LAYOUT OF SERVICES IN FOOTPATH / ROAD TYPICAL LAYOUT FOR SEWER WITHIN NEW DEVELOPMENTS DRAWING No. STD-WW-02

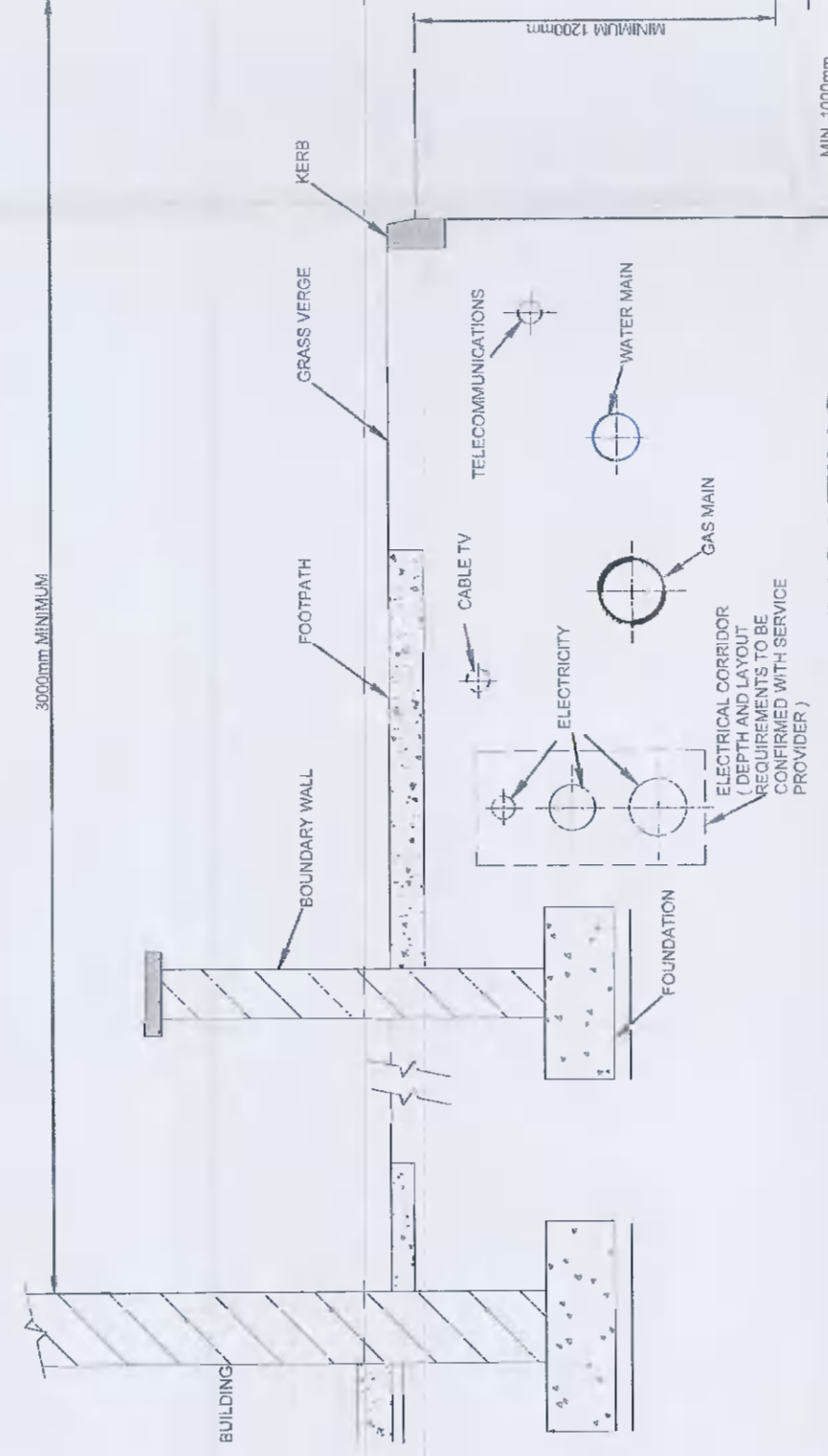
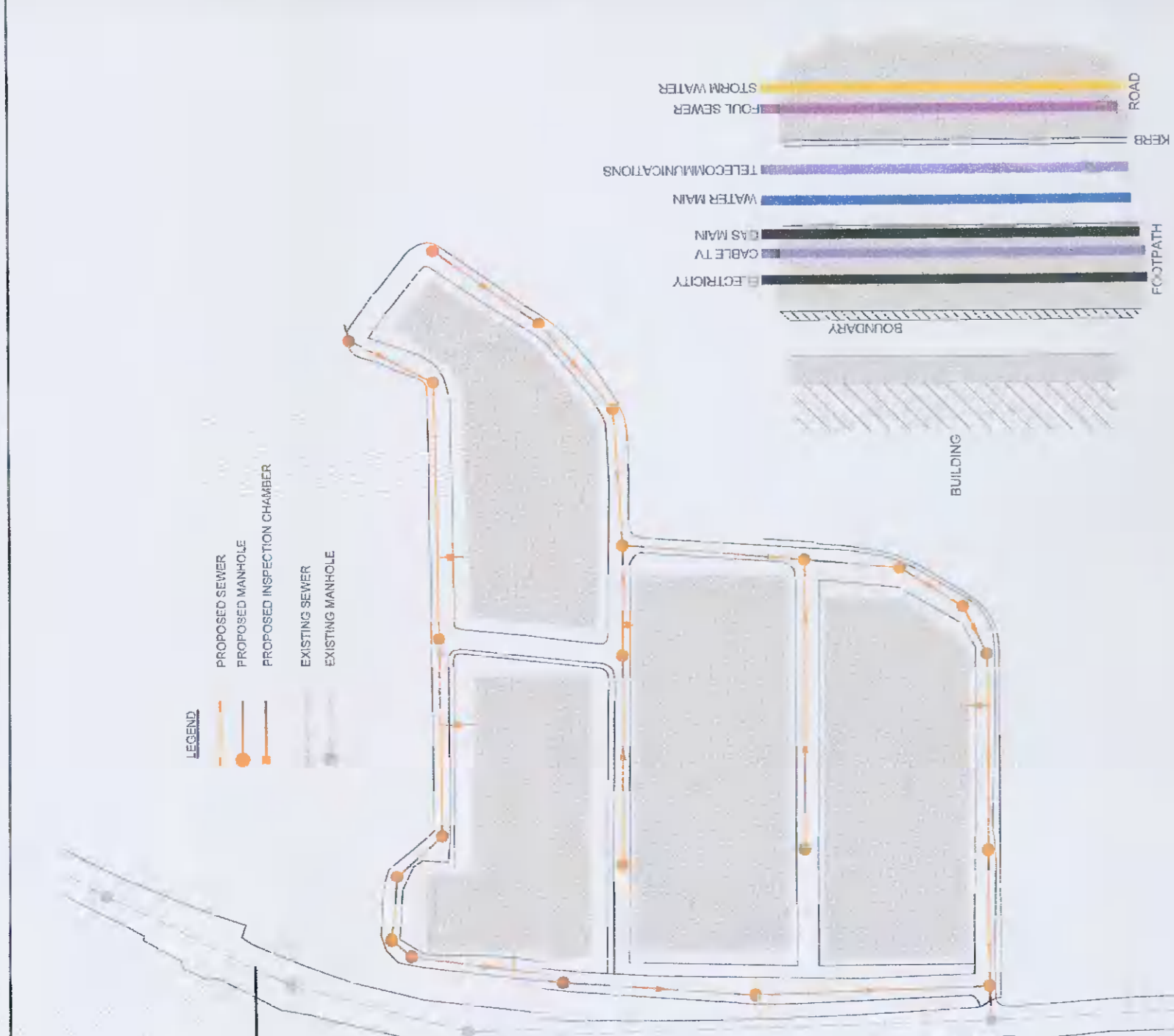

TYPICAL SERVICE LAYOUT INDICATING SEPARATION DISTANCES

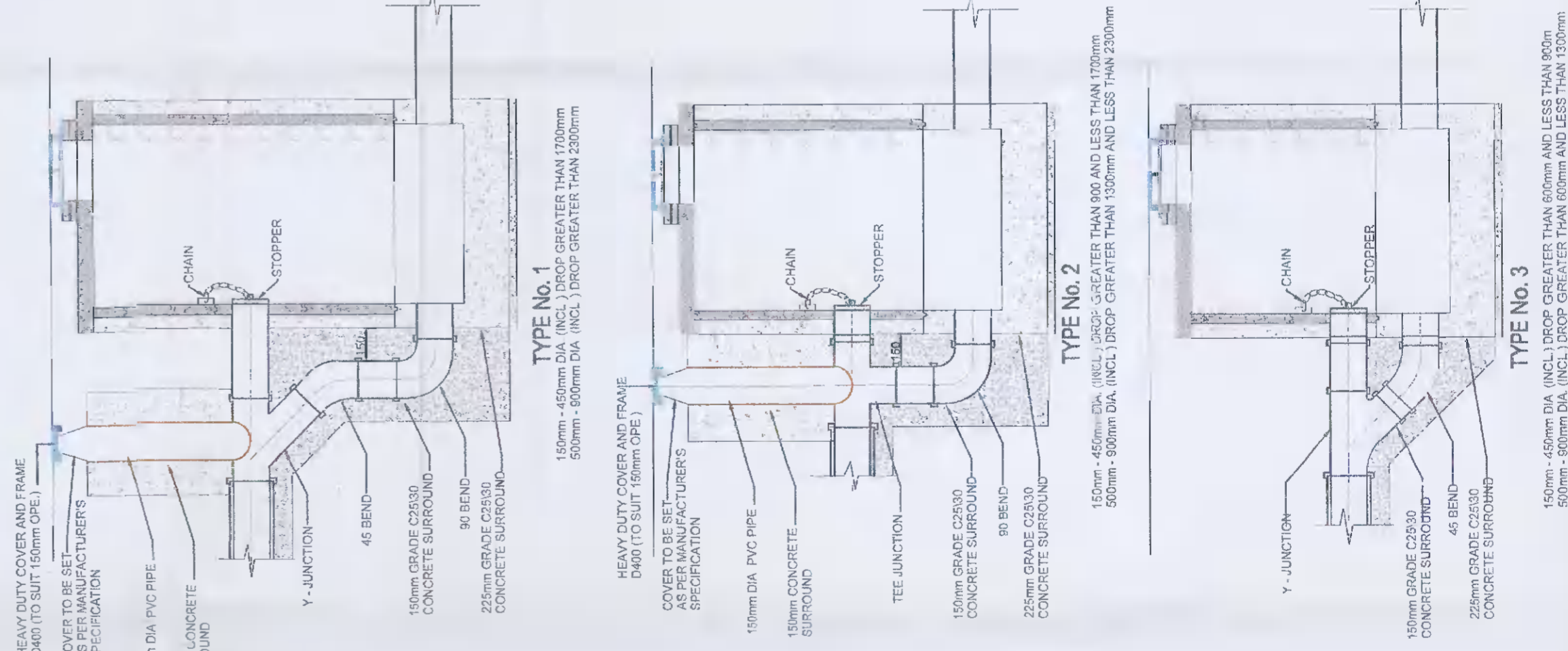

TYPICAL SERVICE LAYOUT INDICATING SEPARATION DISTANCES

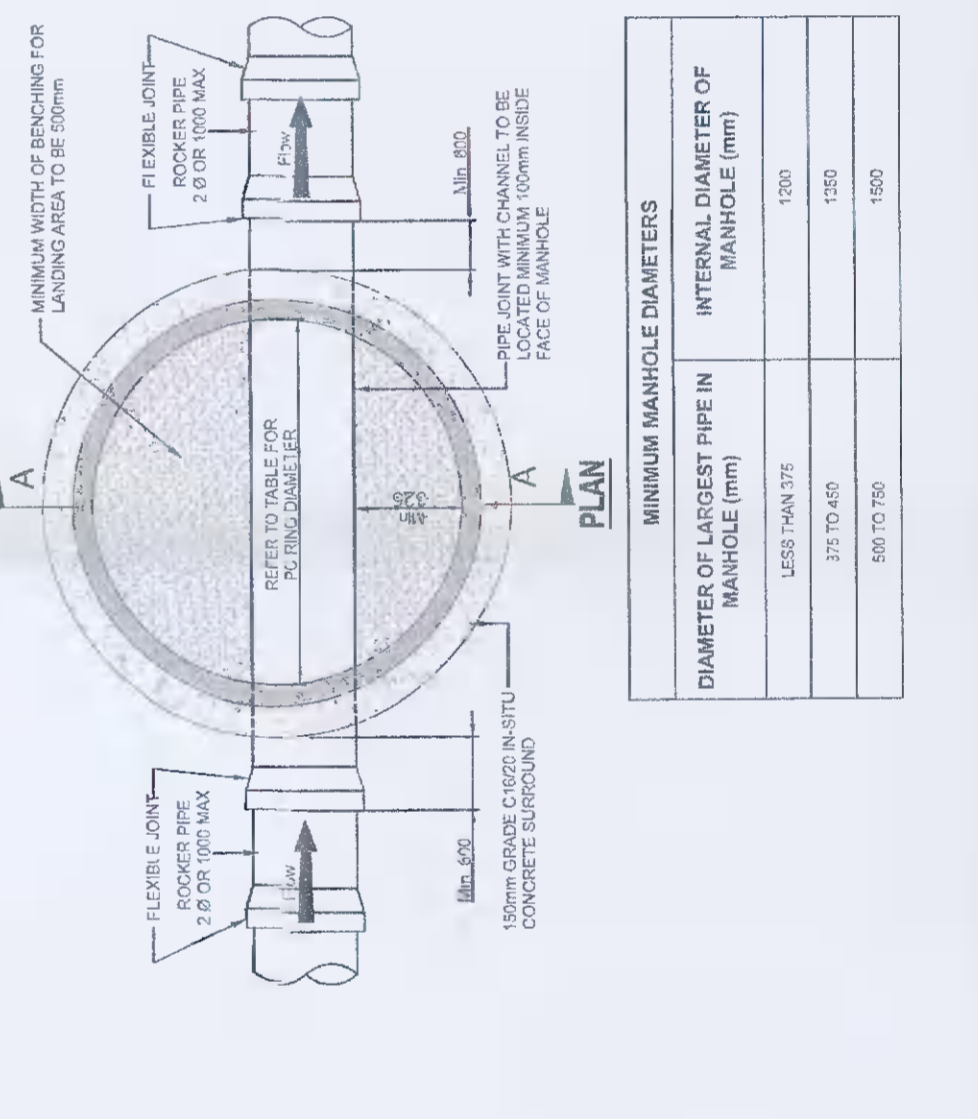
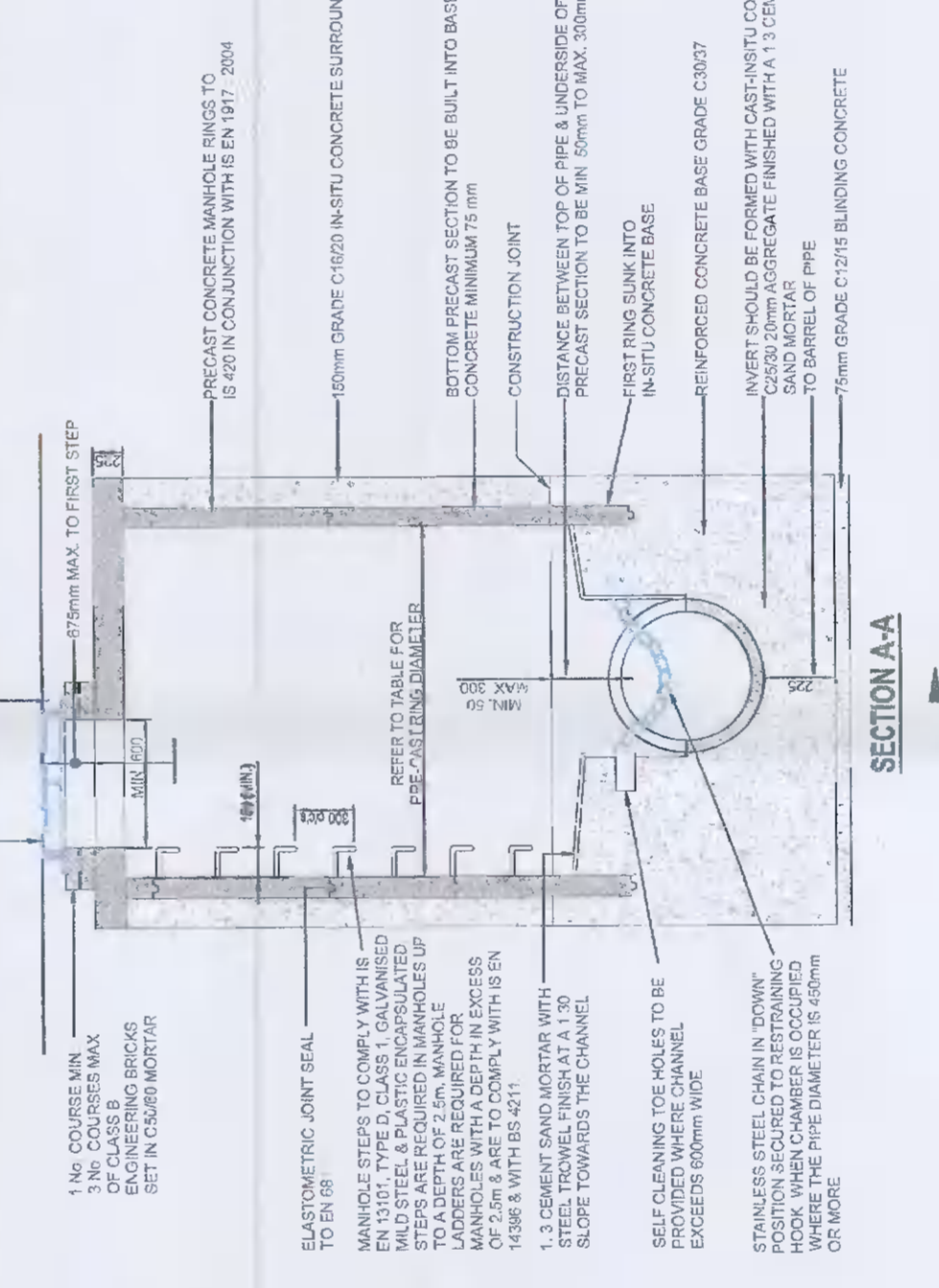

PRE-CAST CONCRETE MANHOLE

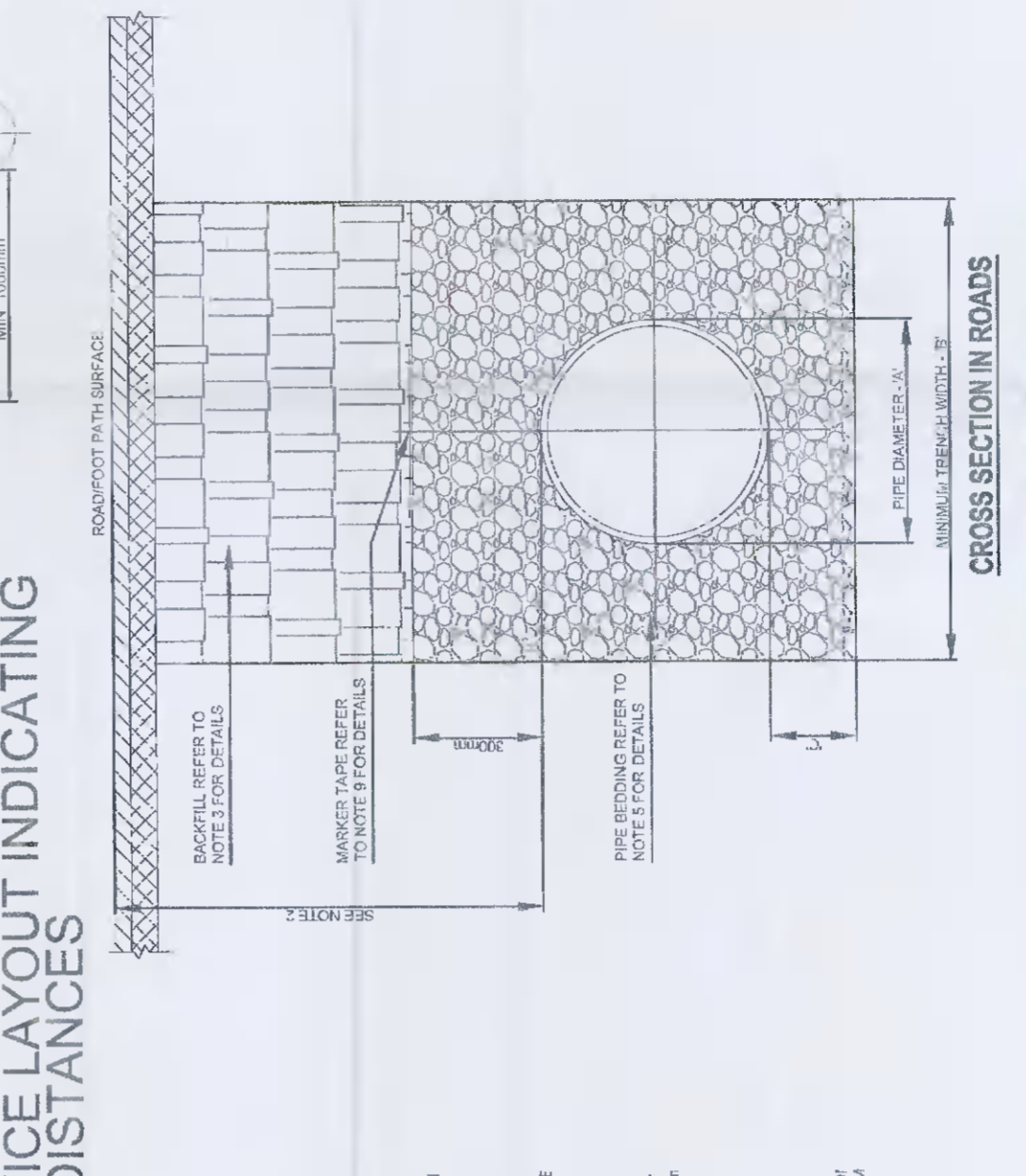

| PIPE DIAMETER 'A' (mm) | TRENCH WIDTH 'B' (mm) | DEPTH OF BEDDING 'C' (mm) |
|------------------------|-----------------------|---------------------------|
| 100 | 600 | 100 |
| 150 | 600 | 100 |
| 200 | 600 | 100 |
| 250 | 750 | 200 |
| 300 | 750 | 200 |
| 350 | 750 | 200 |
| 400 | 900 | 200 |
| 450 | 900 | 200 |

TRENCH BACKFILL AND BEDDING

| REV | DESCRIPTION | BY | CHK | DATE |
|-----|-------------|----|-----|------|
| | | | | |

CLIENT
EDGECONEX

PROJECT
**EDCDUB05
& GAS PLANT**

DRAWING TITLE
**STANDARD WASTE WATER
INFRASTRUCTURE DETAILS**

**PINNACLE
CONSULTING ENGINEERS**

GROSVENOR COURT,
15-17 GROSVENOR STREET,
DUN LAOGHAIRE,
COUNTY DUBLIN
IRELAND.
TELEPHONE: +353 1231 1041
WELWYN GARDEN CITY | NORWICH | THE HAGUE

| | |
|----------------|----------------------|
| DRAWING STATUS | PLANNING |
| SCALE @ A1 | DATE |
| NTS | DEC '20 |
| DRAWN BY | JM |
| CHECKED | JKM |
| DRG NO. | PIN-ZZ-ZZ-DR-DR-0205 |
| REVISION | P01 |

BACKDROP MANHOLES